

# M1255 SERIES

## *HOLD-UP POWER SUPPLY*

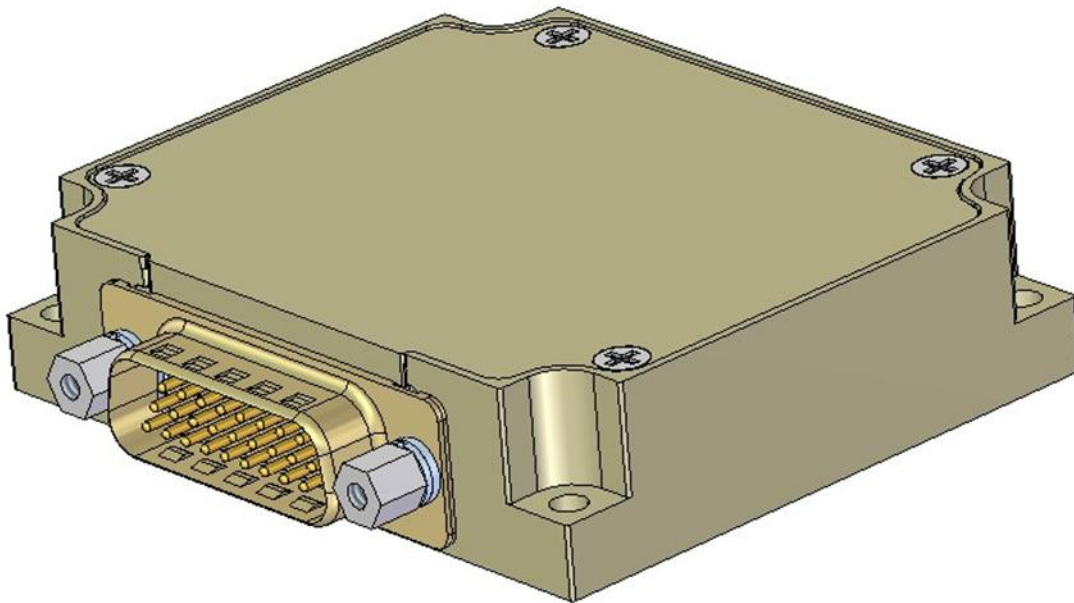

## M1255 Hold -Up Power Supply

### THE MAIN FEATURES OF THE M1255 SERIES ARE:

- Miniature size
- High efficiency
- Wide input range
- Fixed switching frequency
- External Synchronization ( $250 \pm 10$  kHz)
- EMI filters included
- Indication for Input failure and Hold-Up activation
- External capacitor required.
- Operates together with MPS standard modules. Please consult factory for specific applications.
- More than 990 W/msec per 1 mF capacitance
- Input Reverse Polarity - Protection for unlimited time

## M1255 Hold -Up Power Supply

### Electrical Specifications

#### **DC INPUT**

DC Input range: 18 to 50 V<sub>DC</sub>

Input transient protection:

All models meet or exceed (no damage) MIL-STD-1275A (100V for 50ms) and MIL-STD-704A, MIL-STD-704D (80V for 0.1Sec)

EMC:

Designed to meet\* MIL-STD-461F:

CE101, CE102, CS106, C101, RE102, RS102, RS103

Isolation:

200V between Input and Case 200V between Output and Case

#### **DC OUTPUT**

Same as input voltage (-1V max) at max current:

$I_{out}$ : max 15A

#### **SYNC**

- The unit can sync for external synchronization.
- The synchronization should be 250KHZ  $\pm$  10KHZ and the synchronization level should be 12V MAX.
- The level of synchronization can be change at the request of a customer, please consult to factory.

#### **VIN FAIL**

- This is open collector signal.
- When Input voltage is within tolerance (good) the signal is open.
- When Input voltage is out of tolerance (fail) the signal is close.

Steady State output current:

DC output current following input current

### Environmental Conditions

Meets or exceeds MIL-STD-810F Temperature:

Operating: -55°C to +85°C (baseplate) Storage: -55°C to +125°C

Vibration level:

Up to 9 grms.

For higher vibration levels - please consult factory.

### Reliability

150,000 hours, calculated per MIL-STD-217F at +85°C baseplate, Ground Fixed.

**\* Compliance achieved when tested with shielded cable and static resistive load.**

# M1255 Hold -Up Power Supply

## Connection Diagram

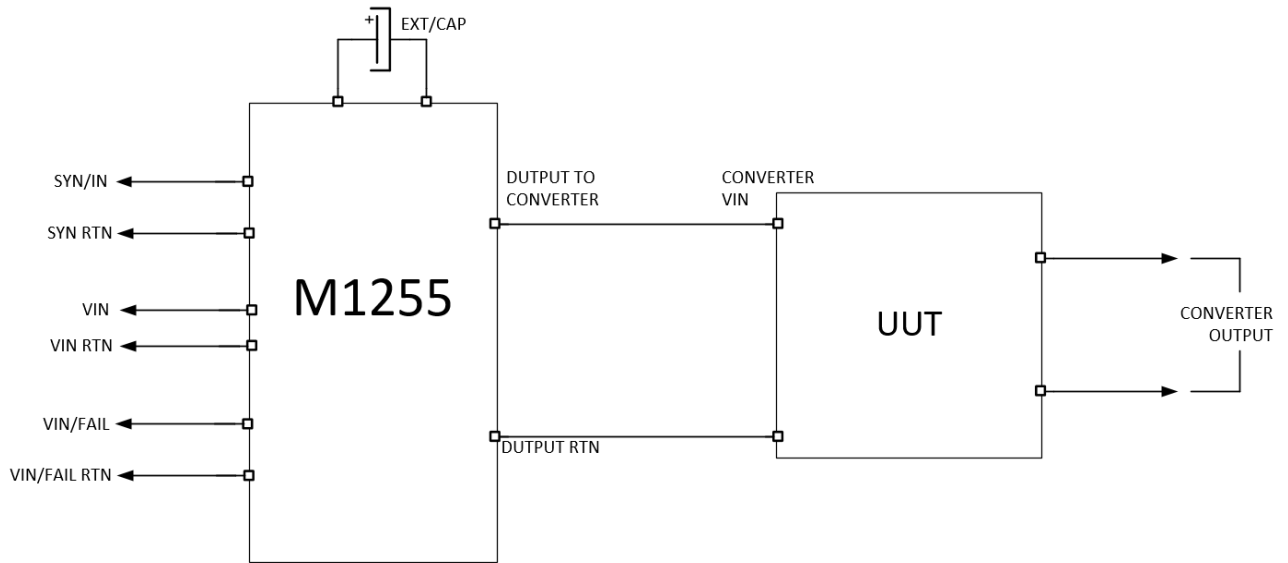

## Block Diagram

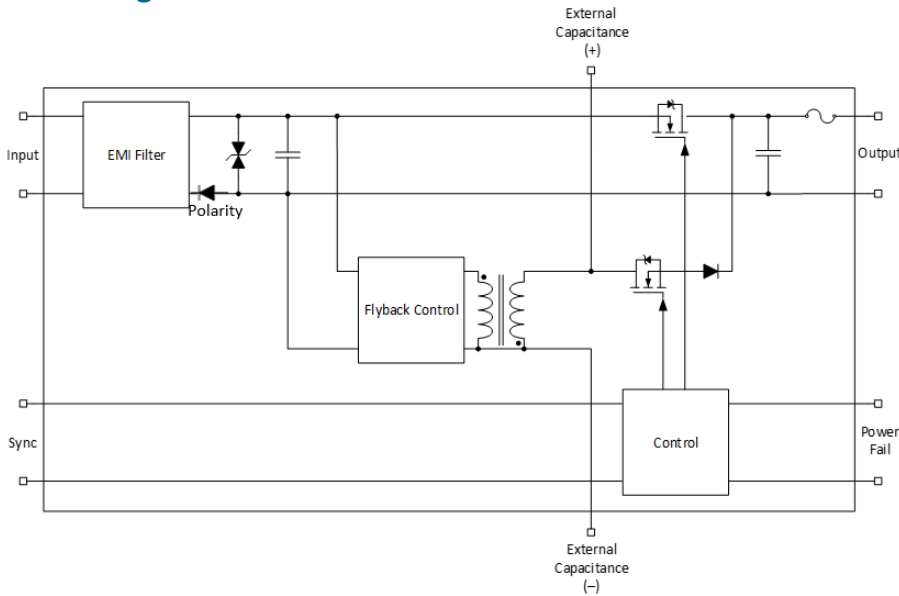

## M1255 Hold -Up Power Supply

### Description of Operation

The holdup unit is meant to be installed in front of a power supply, and not a standalone. It is used for input voltage holding when a power failure occurs, such that if the input power returns to nominal limits in a defined period of time, the load can't tell that a power failure had happened.

This unit is designed to be used with most of Enercon's DC/DC converters and DC/AC inverters (consult factory for applicability to specific models).

During normal operation, an internal converter charges the external capacitor to 50 V.

In case a power failure occurs where the input voltage drops below 17-18V, the input is disconnected from the output via a MOSFET switch, and the external cap is connected to the output pins through another MOSFET switch. The external cap is then discharged into the cascaded power supply, dropping towards 17-18V, where the cascaded power supply ceases to operate.

When input power returns (it can happen during cap discharge or after complete loss of power), the MOSFET switches disconnect the output from the external cap, reconnect the input to the output, and the internal converter recharges the external cap back to 48-51V, preparing it for the next power failure.

### The equation for calculation of the holdup capacitance

$$C_{holdup} = \frac{2 \times P_{typ} \times T_{off}}{V_{charge}^2 - V_{min}^2}$$

Where

- 1)  $C_{holdup}$  = minimum holdup capacitance
- 2)  $P_{typ}$  = typical power when power interrupt can occur
- 3)  $T_{off}$  = power interrupt duration (50 msec IAW MIL-STD-704)
- 4)  $V_{charge}$  = charge voltage of holdup capacitor
- 5)  $V_{min}$  = minimum operating voltage at the end of the power interrupt

## M1255 Hold -Up Power Supply

### Pin Assignment

**Connector type:** ODD26M4000C-15 or eq.

**Mates with:** ODD26S100EC-15 or eq.

Pin No.	Pin Function	Polarity
7, 8, 9, 18	VIN	(+)
16, 17, 25, 26	VIN RTN	(-)
10	SYNC	(+)
19	SYNC RTN	(-)
20	VIN FAIL	(+)
11	VIN FAIL RTN	(-)
1, 2	EXTERNAL CAPACITOR	(+)
23, 24	EXTERNAL CAPACITOR RTN	(-)
3, 4, 12, 13	OUTPUT TO CONVERTER	(+)
5, 6, 14, 15	OUTPUT RTN TO CONVERTER	(-)
21	CHASSIS	

### Signals Description

#### **INPUT FAIL\*** (pin 20)

This signal is used to communicate an input voltage failure condition.  
Signal type is open collector of a PMBT2222 bipolar transistor.

#### **FAIL:**

Condition: Input voltage was within normal range and dropped below  $17.6 \pm 0.5$  V.

Result: The pin will be pulled down to **INPUT FAIL RTN** pin through a  $6.2 \Omega$  resistor.

#### **NORMAL:**

Condition: Input voltage returned to above  $17.6 \pm 0.5$  V.

Result: The pin will go into high impedance mode (OPEN).

If this function is not required, leave this pin unconnected.

This signal is referenced to **INPUT FAIL RTN** (pin 11)

#### **SYNC** (pin 10)

**This signal is used to synchronize the internal switching converter's frequency to external clock.**

Valid external clock frequency is  $250 \text{ kHz} \pm 10 \text{ kHz}$ ; Valid duty cycle:  $50 \pm 10\%$

When no external clock is present, the power supply uses its internal clock.

If this function is not required, leave pin unconnected.

This signal is referenced to **SYNC RTN** (pin 19)

#### **EXT CAP** (pins 1 and 2)

**Connect these pins to external capacitor for increased holdup time.**

Unless specified otherwise in the specific variant's catalog page, the voltage at these pins is set to  $51 V_{DC} \pm 2V$ .

These pins are referenced to **EXT CAP RTN** (pins 23 and 24).

## M1255 Hold -Up Power Supply

### Outline Drawing

For detailed dimensions and tolerances see Drawing: M1255-100

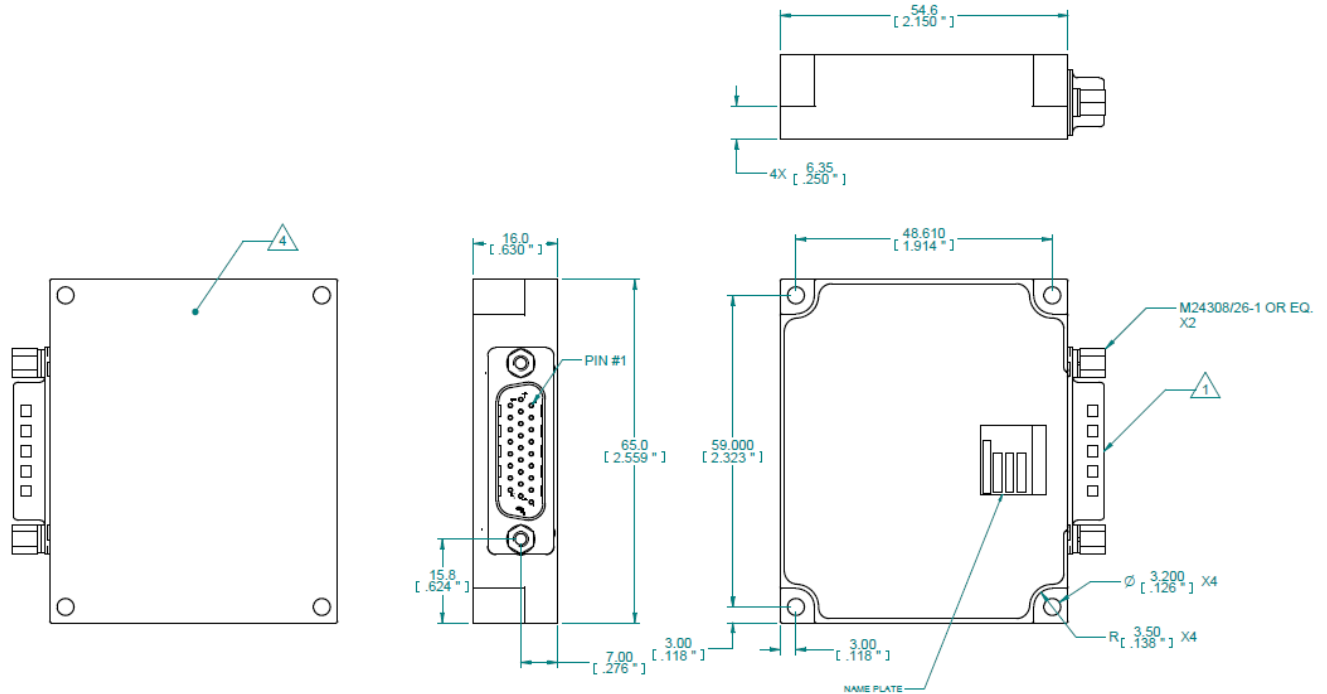

#### NOTES :

1. I/O CONNECTOR P/N: ODD26M4000C-15 OR EQ.
2. MTL. AL 6061-T651.
3. FINISH:
  - 3.1. CHROMATE CONVERSION COATING PER MIL -DTL-5541, LAST REVISION, TYPE I, CLASS 1A, OR EQ.
4. COOLING: HEAT DISSIPATION AREA- 5.4 [in<sup>2</sup>], 3,500 [mm<sup>2</sup>] .
5. WORKMANSHIP SHALL BE MIL-STD-454, REQT. 9

**\* Specifications are subject to change without prior notice by the manufacturer.**