

# M1912 SERIES

## *300W Dual Output AC to DC Baseplate Cooled Power Supply*



### PRODUCT DESCRIPTION

The M1912 is a series of mechanically robust, base plate cooled, high performance, 300W dual output AC to DC power supplies, for Navy shipboard, Airborne, and ground applications. The M1912 converts 115VAC – 230VAC/50-60Hz or 115VAC 400Hz, to a well-regulated, filtered and protected main DC Output 280W and Auxiliary output 20W.

The product meet MIL-STD requirements (specified herein).

## M1912 Series– AC/DC Power Supply

### STANDARD CONFIGURATIONS

Part number	Input		Main Output		Aux Output		ON/OFF Logic
	Voltage range	Frequency	Voltage	Current	Voltage	Current	
M1912-100	Single-phase, 85 to 265 V <sub>AC</sub>	50/60/400 Hz	12 V <sub>DC</sub>	20 A	3.3 V <sub>DC</sub>	5 A	Enable
M1912-101	Single-phase, 85 to 265 V <sub>AC</sub>	50/60/400 Hz	12 V <sub>DC</sub>	20 A	3.3 V <sub>DC</sub>	5 A	Inhibit
M1912-102	Single-phase, 85 to 265 V <sub>AC</sub>	50/60/400 Hz	12 V <sub>DC</sub>	20 A	5 V <sub>DC</sub>	3.3 A	Enable
M1912-103	Single-phase, 85 to 265 V <sub>AC</sub>	50/60/400 Hz	12 V <sub>DC</sub>	20 A	5 V <sub>DC</sub>	3.3 A	Inhibit <sup>1</sup>
M1912-104	Single-phase, 85 to 265 V <sub>AC</sub>	50/60/400 Hz	24 V <sub>DC</sub>	12A	3.3 V <sub>DC</sub>	5 A	Inhibit <sup>1</sup>
M1912-106	Single-phase, 85 to 265 V <sub>AC</sub>	50/60/400 Hz	24 V <sub>DC</sub>	12A	5 V <sub>DC</sub>	3.3 A	Inhibit <sup>1</sup>
M1912-108	Single-phase, 85 to 265 V <sub>AC</sub>	50/60/400 Hz	24 V <sub>DC</sub>	12A	12 V <sub>DC</sub>	1.5 A	Inhibit <sup>1</sup>
M1912-110	Single-phase, 85 to 265 V <sub>AC</sub>	50/60/400 Hz	28 V <sub>DC</sub>	10A	3.3 V <sub>DC</sub>	5 A	Inhibit <sup>1</sup>
M1912-112	Single-phase, 85 to 265 V <sub>AC</sub>	50/60/400 Hz	28 V <sub>DC</sub>	10A	5 V <sub>DC</sub>	3.3 A	Inhibit <sup>1</sup>
M1912-114	Single-phase, 85 to 265 V <sub>AC</sub>	50/60/400 Hz	28 V <sub>DC</sub>	10A	12 V <sub>DC</sub>	1.5 A	Inhibit <sup>1</sup>
M1912-116	Single-phase, 85 to 265 V <sub>AC</sub>	50/60/400 Hz	48 V <sub>DC</sub>	5.5A	3.3 V <sub>DC</sub>	5 A	Inhibit <sup>1</sup>
M1912-118	Single-phase, 85 to 265 V <sub>AC</sub>	50/60/400 Hz	48 V <sub>DC</sub>	5.5A	5 V <sub>DC</sub>	3.3 A	Inhibit <sup>1</sup>
M1912-120	Single-phase, 85 to 265 V <sub>AC</sub>	50/60/400 Hz	48 V <sub>DC</sub>	5.5A	12 V <sub>DC</sub>	1.5 A	Inhibit <sup>1</sup>

- Note: <sup>1</sup>Enable logic is available - **Contact factory for more details.**
- Additional standard configurations available. **Contact factory for more details.**
- All of our products can be configured to comply with **EU REACH** regulations. **Contact factory for more details.**
- For **CE MARKING** (IEC 62368-1) configuration - **Contact factory for more details.**

## M1912 Series– AC/DC Power Supply

### MAIN FEATURES

- AC/DC Dual output power supply up to 300W
- Single phase input (50/60/400Hz)
- Withstands MIL-STD-1399-300B 1,000 V spikes
- Complies with MIL-STD-461F for shipboard application
- Complies with MIL-STD-167-1 (Type I) shipboard vibration
- Robust mechanical design, intended for systems that should withstand MIL-DTL-901E high impact shocks
- High power factor (Full load PF of above 0.9)
- Main output 12V to 48V @ Max 280W
- Aux. output 3.3V to 12V @ Max 20W
- High efficiency
- Full galvanic isolation between Input, Chassis and Outputs.
- Inrush Current Limiter
- External Inhibit (On/Off)
- Fixed switching freq. (250 kHz)
- EMI filters included
- Remote sense compensation for Auxiliary output
- Indefinite short circuit protection with auto-recovery
- Over-voltage shutdown with auto-recovery
- Over temperature shutdown with auto-recovery
- High density
- Conduction cooled via the baseplate
- J-STD-001B and IPC-610A Class-3 workmanship
- Conformal Coating per MIL-I-46058C and IPC-CC-830

## M1912 Series– AC/DC Power Supply

### SPECIFICATIONS

<b>AC Input</b>	<b>Voltage and Frequency</b>	<p><b>Option 1:</b> 85 to 265 V<sub>AC</sub> ; 50/60Hz Single-phase, 5A<sub>max</sub> IAW MIL-STD-1399-300B, Type I (115 V<sub>rms</sub>/ 60Hz)</p> <p><b>Option 2:</b> 103 to 127 V<sub>AC</sub> ; 400Hz Single-phase, 5A<sub>max</sub></p>												
	<b>Under Voltage shutdown</b>	Unit protects itself (no damage) below 75 VAC @ full load.												
	<b>Inrush Current Limiter</b>	Initial input current surge to charge internal capacitances is limited internally.												
	<b>Isolation</b>	<p>Input to Output: 1000 VDC Input to Case: 1000 VDC</p> <p><u>Note:</u> Tested during production, at system level the test Voltage limited to 250V since internal TVS installed between Neutral to Chassis for surge protection. If this feature not required, <b>please consult factory.</b></p>												
<b>DC Output</b>	<b>Output Range</b>	<table border="1" style="width: 100%; border-collapse: collapse;"> <thead> <tr> <th></th> <th>Voltage Range</th> <th>Current</th> <th>Power</th> </tr> </thead> <tbody> <tr> <td>Main Output</td> <td>12V to 48V</td> <td>Up to 20A</td> <td>Up to 280W</td> </tr> <tr> <td>AUX Output</td> <td>3.3V to 12V</td> <td>Up to 5A</td> <td>Up to 20W</td> </tr> </tbody> </table> <p>Main output and Auxiliary output are not isolated from each other. Additional configuration available. <b>Consult factory for details.</b></p>		Voltage Range	Current	Power	Main Output	12V to 48V	Up to 20A	Up to 280W	AUX Output	3.3V to 12V	Up to 5A	Up to 20W
		Voltage Range	Current	Power										
	Main Output	12V to 48V	Up to 20A	Up to 280W										
	AUX Output	3.3V to 12V	Up to 5A	Up to 20W										
	<b>Voltage Regulation</b>	<p>Less than 1% (no load to full load, -40 °C to +85 °C) For voltage output below 5V, Less than 3% (no load to full load, -40 °C to +85 °C)</p>												
	<b>Remote Sense</b>	<p><b>AUX SENSE</b> The AUX SENSE line is used to achieve accurate voltage regulation at load terminals. To use this feature, connect this pin directly to load's positive terminal. If this function is not required, short AUX SENSE pin to AUX OUTPUT pins as close as possible to the unit.</p> <p><b>AUX SENSE RTN</b> The AUX SENSE RTN line is used to achieve accurate voltage regulation at load terminals. To use this feature, connect this pin directly to load's negative terminal. If this function is not required, short SENSE RTN pin to OUTPUT RTN pins as close as possible to the unit.</p> <p><u>Note:</u> The use of remote sense has a limit of voltage dropout between the converter's output and the load's terminals of approximately ±0.5V of nominal output voltage.</p>												
	<b>Turn on Overshoot</b>	Output voltage overshoot during power on < 5%												
<b>Ripple and noise</b>	<p>For V<sub>out</sub>&gt;5V typical max 1% For V<sub>out</sub>&lt; 5V typical max 2% With 1µF external capacitance.</p>													
<b>Isolation</b>	Output to case: 200 VDC													

## M1912 Series– AC/DC Power Supply

	<b>Current Limit &amp; Overload</b>	10 - 30% above maximum current, indefinitely (Hiccup).									
	<b>Efficiency</b>	115 V <sub>rms</sub> / 400 Hz ≥ 80% 230 V <sub>rms</sub> / 50 Hz ≥ 84% (Typical @ 250W load)									
	<b>Overvoltage Protection</b>	<ul style="list-style-type: none"> <li>• <b>Active Over Voltage Protection</b> 10% ± 2% above nominal voltage.</li> <li>• <b>Passive Over Voltage Protection</b> Transorb/Zener at output selected 20%</li> </ul>									
	<b>Over Temp. Protection</b>	Shutdown at base plate temp. above +105°C ± 5°C Automatic recovery at base plate temp. below +95°C ± 5°C.									
<b>Control &amp; Indication</b>	<b>ON/OFF Input</b>	<p>The ENABLE/ INHIBIT signal is used to turn the power supply ON and OFF. The internal pullup voltage is 3.3V typical and the IPULLDOWN (the minimum current to RTN needed to turn on the PSU) is 3mA Typical.</p> <p>Table 1 – Inhibit and Enable Functionality</p> <table border="1" style="width: 100%; border-collapse: collapse;"> <thead> <tr> <th></th> <th>Enable logic</th> <th>Inhibit logic</th> </tr> </thead> <tbody> <tr> <td>'ON'</td> <td>V &lt; 0.8V – P.S 'ON' or Enable = 'SHORT' – P.S 'ON'</td> <td>V &gt; 2.4V – P.S 'ON' or Inhibit = 'OPEN' – P.S 'ON'</td> </tr> <tr> <td>'OFF'</td> <td>V &gt; 2.4V – P.S 'OFF' or Enable = 'OPEN' – P.S 'OFF'</td> <td>Inhibit = 'SHORT' – P.S 'OFF' or V &lt; 0.8V – P.S 'OFF'</td> </tr> </tbody> </table> <p>The ENABLE/ INHIBIT signal is floating form output return.</p> <p>Optional to applied 28V between Inhibit pin to signal RTN to active the power supply (output turned on)- <b>Please consult factory.</b></p> <p><u>SIGNAL RTN</u> This signal is used as grounding for ENABLE/INHIBIT signal. Signal RTN is isolated from output.</p>		Enable logic	Inhibit logic	'ON'	V < 0.8V – P.S 'ON' or Enable = 'SHORT' – P.S 'ON'	V > 2.4V – P.S 'ON' or Inhibit = 'OPEN' – P.S 'ON'	'OFF'	V > 2.4V – P.S 'OFF' or Enable = 'OPEN' – P.S 'OFF'	Inhibit = 'SHORT' – P.S 'OFF' or V < 0.8V – P.S 'OFF'
	Enable logic	Inhibit logic									
'ON'	V < 0.8V – P.S 'ON' or Enable = 'SHORT' – P.S 'ON'	V > 2.4V – P.S 'ON' or Inhibit = 'OPEN' – P.S 'ON'									
'OFF'	V > 2.4V – P.S 'OFF' or Enable = 'OPEN' – P.S 'OFF'	Inhibit = 'SHORT' – P.S 'OFF' or V < 0.8V – P.S 'OFF'									
<b>Environment</b>	<b>Temperature</b>	MIL-STD-810F, Methods 501.4 & 502.4 Operating: –40°C to +85°C (at baseplate) Storage: –55°C to +125°C (ambient)  <b>Optional:</b> Operating -55°C to +85°C (at baseplate). Consult factory for details.									
	<b>Humidity</b>	MIL-STD-810F, Method 507.4 Up to 95% RH									
	<b>Salt-fog</b>	MIL-STD-810F, Method 509.4									
	<b>Altitude</b>	MIL-STD-810F, Method 500.4 Procedures I – Storage/Air transport: up to 70,000 ft. (non-operational) Procedure II – Operation/Air Carriage: up to 40,000 ft. (operational)									

## M1912 Series– AC/DC Power Supply

	<b>Mechanical Shock</b>	<p><u>MIL-STD-810F, Method 516.5,</u></p> <ul style="list-style-type: none"> <li>• Procedure I -Functional shock, 40g, 15 -23 ms, Terminal Peak, Sawtooth shock pulse</li> <li>• Procedure V - Crash Hazard, 40g, 15 -23 ms, Terminal Peak, Sawtooth shock pulse</li> </ul> <p><u>MIL-S-901D:</u> Withstands the high-impact shipboard shock IAW MIL-S-901D, Grade A, Class I and II</p>																							
	<b>Vibration</b>	<p>MIL-STD 810F, Method 514.5, Procedure I, Category 24, General minimum integrity exposure, IAW Figure 514.5C-17, 1 hour per axis.</p> <p>Type I vibration IAW MIL-STD-167-1A</p>																							
	<b>Fungus</b>	Does not support fungus growth (MIL-STD-810G, Method 508.6)																							
<b>EMC</b>	<i>Designed to meet</i> * <b>MIL-STD-461F</b>	<table border="1" style="width: 100%; border-collapse: collapse;"> <tr> <td>Conducted Emission</td> <td>CE101, CE102</td> </tr> <tr> <td>Conducted Susceptibility</td> <td>CS101, CS114, CS115, CS116</td> </tr> <tr> <td>Radiated Emission</td> <td>RE101, RE102</td> </tr> <tr> <td>Radiated Susceptibility</td> <td>RS101, RS103</td> </tr> </table> <p>* All tests are at full load and in accordance with the provisions of MIL-STD-461F – with shielded Output and Signals cables.</p>	Conducted Emission	CE101, CE102	Conducted Susceptibility	CS101, CS114, CS115, CS116	Radiated Emission	RE101, RE102	Radiated Susceptibility	RS101, RS103															
	Conducted Emission	CE101, CE102																							
	Conducted Susceptibility	CS101, CS114, CS115, CS116																							
Radiated Emission	RE101, RE102																								
Radiated Susceptibility	RS101, RS103																								
<b>EN/IEC</b>	<table border="1" style="width: 100%; border-collapse: collapse;"> <tr> <td>Radiated Emission</td> <td>EN55032 CLASS A</td> </tr> <tr> <td>Conducted Emission</td> <td></td> </tr> <tr> <td>Harmonic current Emission</td> <td>IEC6100-3-2 CLASS A</td> </tr> <tr> <td>Voltage Fluctuation &amp; Flicker</td> <td>IEC6100-3-3</td> </tr> </table>	Radiated Emission	EN55032 CLASS A	Conducted Emission		Harmonic current Emission	IEC6100-3-2 CLASS A	Voltage Fluctuation & Flicker	IEC6100-3-3																
Radiated Emission	EN55032 CLASS A																								
Conducted Emission																									
Harmonic current Emission	IEC6100-3-2 CLASS A																								
Voltage Fluctuation & Flicker	IEC6100-3-3																								
<i>Immunity Test</i> (EN/IEC)	<table border="1" style="width: 100%; border-collapse: collapse;"> <thead> <tr> <th>Test Type</th> <th>Test Method</th> <th>Test Type/Level/Class</th> </tr> </thead> <tbody> <tr> <td>ESD</td> <td>EN61000-4-2</td> <td>Enclosure; Contact; ±4kV; [B]</td> </tr> <tr> <td>Radiated Immunity</td> <td>EN61000-4-3</td> <td>(80-6000) MHz; 10V/m; [A]</td> </tr> <tr> <td>EFT</td> <td>EN61000-4-4</td> <td>±2kV; [B]</td> </tr> <tr> <td>Surge</td> <td>EN61000-4-5</td> <td>L-L: ±1kV; [B] L-E: ±2kV; [B]</td> </tr> <tr> <td>Conducted Immunity</td> <td>EN61000-4-6</td> <td>150kHz – 80MHz ; 10Vrms; [A]</td> </tr> <tr> <td>Magnetic Field</td> <td>EN61000-4-8</td> <td>50Hz; 30A/m; [A]</td> </tr> <tr> <td>Voltage dips and short interruptions</td> <td>EN61000-4-11</td> <td>50Hz; (100/60/30)%; [B &amp; C]</td> </tr> </tbody> </table>	Test Type	Test Method	Test Type/Level/Class	ESD	EN61000-4-2	Enclosure; Contact; ±4kV; [B]	Radiated Immunity	EN61000-4-3	(80-6000) MHz; 10V/m; [A]	EFT	EN61000-4-4	±2kV; [B]	Surge	EN61000-4-5	L-L: ±1kV; [B] L-E: ±2kV; [B]	Conducted Immunity	EN61000-4-6	150kHz – 80MHz ; 10Vrms; [A]	Magnetic Field	EN61000-4-8	50Hz; 30A/m; [A]	Voltage dips and short interruptions	EN61000-4-11	50Hz; (100/60/30)%; [B & C]
Test Type	Test Method	Test Type/Level/Class																							
ESD	EN61000-4-2	Enclosure; Contact; ±4kV; [B]																							
Radiated Immunity	EN61000-4-3	(80-6000) MHz; 10V/m; [A]																							
EFT	EN61000-4-4	±2kV; [B]																							
Surge	EN61000-4-5	L-L: ±1kV; [B] L-E: ±2kV; [B]																							
Conducted Immunity	EN61000-4-6	150kHz – 80MHz ; 10Vrms; [A]																							
Magnetic Field	EN61000-4-8	50Hz; 30A/m; [A]																							
Voltage dips and short interruptions	EN61000-4-11	50Hz; (100/60/30)%; [B & C]																							
<b>Cooling Requirements</b>	The M1912 is a baseplate cooled unit. The base of the M1912 should be thermally attached to a suitable heatsink that maintains it below +85 °C.																								

## M1912 Series– AC/DC Power Supply

<b>Form factor</b>	119.4 mm wide, 30 mm high and 177.8 mm deep. The base should be mechanically and thermally attached to a user provided coldplate (see Page 9 and 10). For detailed dimensions and tolerances see Drawing: M1912-100
<b>Weight</b>	1150g (Typical)
<b>Reliability</b>	150,000 hours, calculated IAW MIL-HDBK-217F Notice 2 at +65°C baseplate, Ground fixed conditions.

### OPERATIONAL BLOCK DIAGRAM

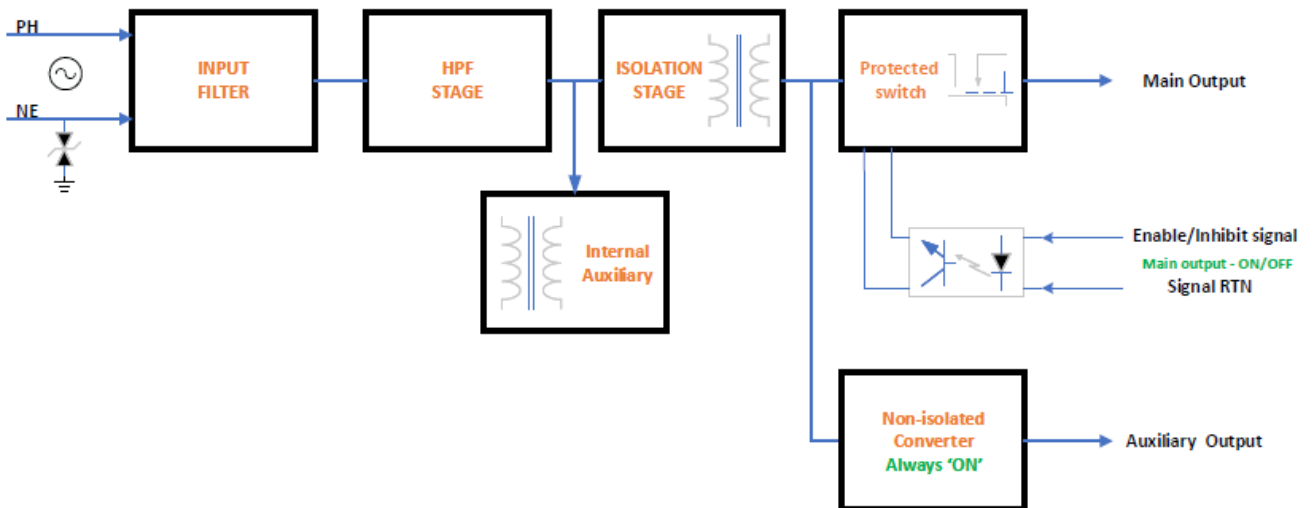

## M1912 Series– AC/DC Power Supply

### PIN ASSIGNMENT

J1 – AC Input connector	
Type: Positronic CBM3W3M550000 OR EQ.	
Mates with: Shell: positronic CBM3W3S00000 + Pins: FC4016D-15 (X3) – #16 CRIMP CONTACTS	
Pin	Fucntion
A1	NEUTRAL
A2	PHASE
A3	CHASSIS *

J2 – DC Output connector			
Type: HDC25S50000-15 OR EQ.			
Mates with: M24308/4-3Z OR EQ.			
Pin	Fucntion	Pin	Fucntion
1	AUX SENSE RTN	14	AUX SENSE
2	SIGNAL RTN	15	N/A
3	ENABLE/ INHIBIT	16	AUX OUTPUT
4	AUX OUTPUT	17	OUTPUT RTN
5	OUTPUT RTN	18	OUTPUT RTN
6	OUTPUT RTN	19	OUTPUT RTN
7	OUTPUT RTN	20	OUTPUT RTN
8	OUTPUT RTN	21	OUTPUT RTN
9	OUTPUT RTN	22	OUTPUT
10	OUTPUT	23	OUTPUT
11	OUTPUT	24	OUTPUT
12	OUTPUT	25	OUTPUT
13	OUTPUT		

\* The CHASSIS pin allows additional connection of unit's chassis to system ground.

### TYPICAL CONNECTION DIAGRAM

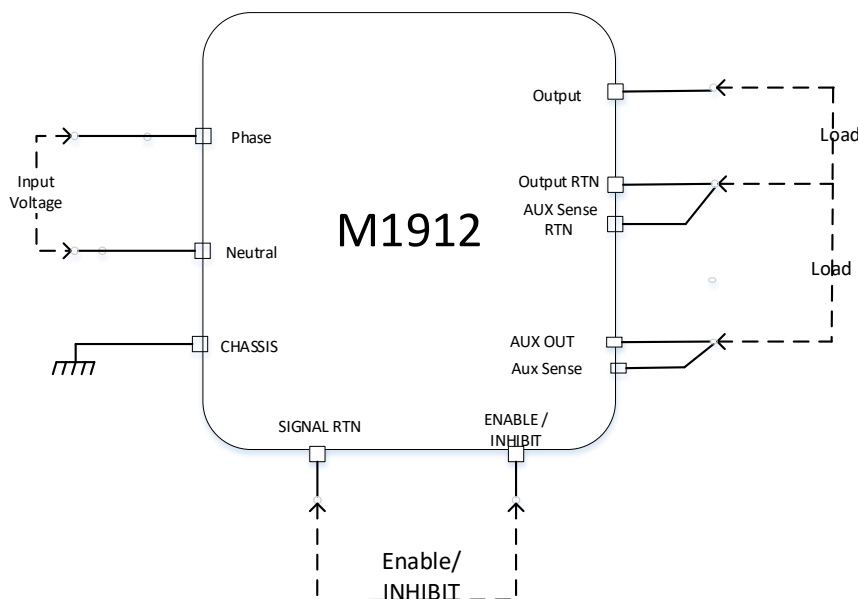

M1912 Series– AC/DC Power Supply

OUTLINE DRAWING

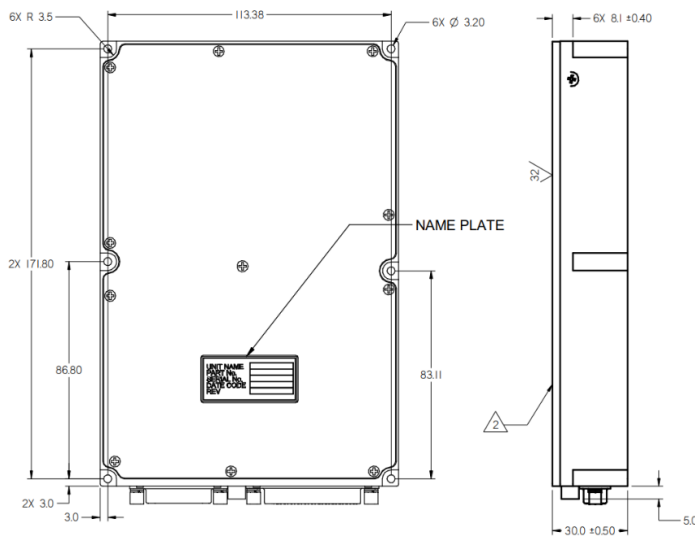
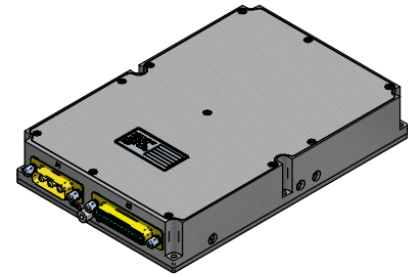
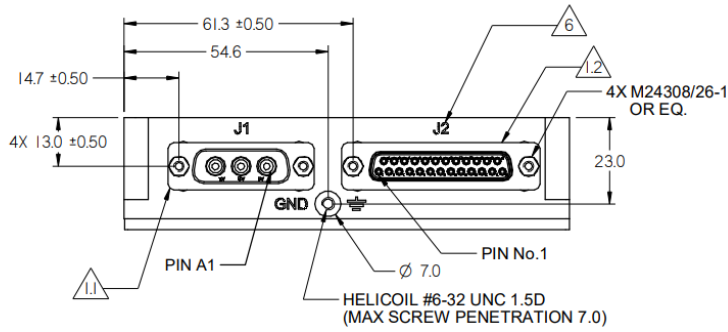

## M1912 Series– AC/DC Power Supply

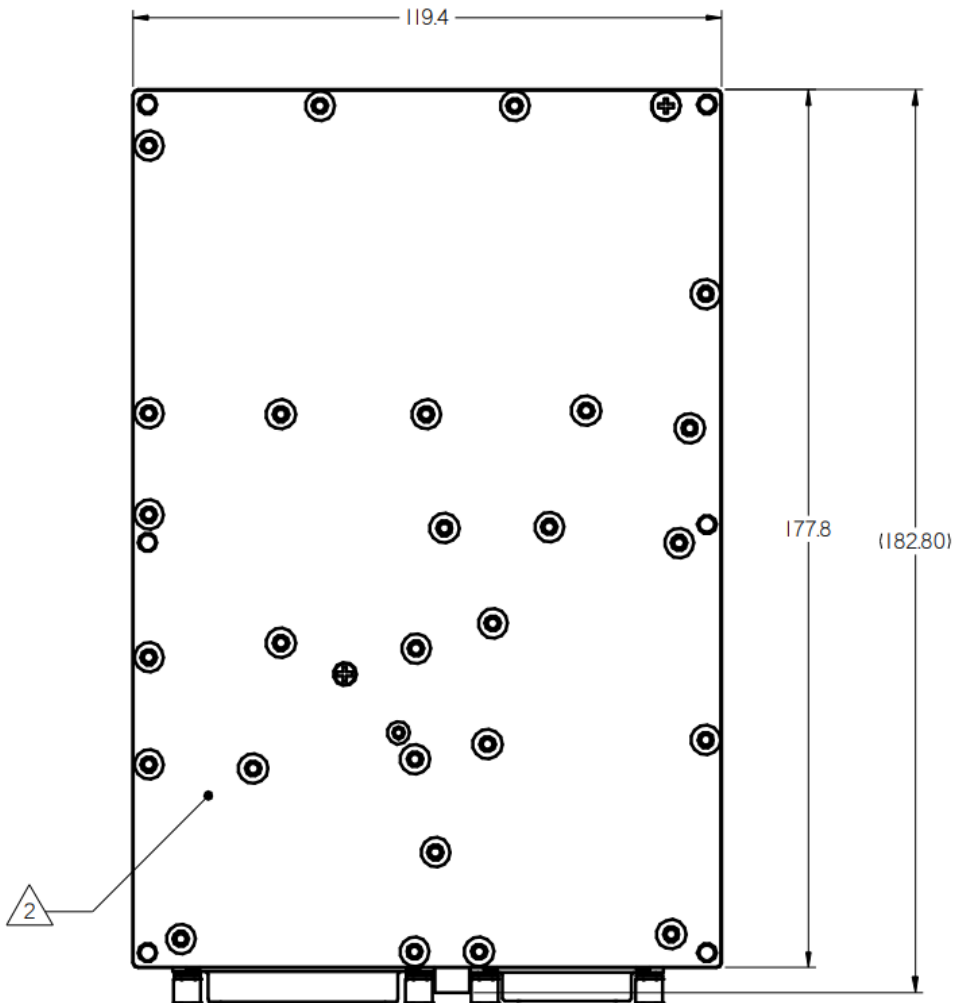

### NOTES :

1. CONNECTORS:
  - 1.1: J1 - INPUT CONNECTOR - CBM3W3M550000 OR EQ.
  - 1.2: J2 - OUTPUT CONNECTOR - HDC25S50000-15 OR EQ.
2. HEAT DISSIPATION SURFACE - TOTAL AREA 20,300mm<sup>2</sup>
3. WORKMANSHIP SHALL BE MIL-STD-454, REQ. 9
4. MTL. AL 6061-T651& AL 5052-H32
5. CHROMATE CONVERSION COATING PER MIL -DTL-5541F,TYPE 1 OR 2 CLASS 1A
6. ENGRAVING:  
CHARACTERS HEIGHT: 3 (mm), DEPTH: 0.4 (mm).  
ENGRAVING FILLED WITH BLACK COLOR.

- These figures are for reference only. For more details, please contact us.

*Note: Specifications are subject to change without prior notice by the manufacturer*