

M2192 SERIES

Power Supply Data Sheet

3U VPX 28V 600W - SOSA Aligned

VITA 47.1 CC4/CCW7 NT4 V3 OS2 C4 AV2 SF1/SF3 CS5

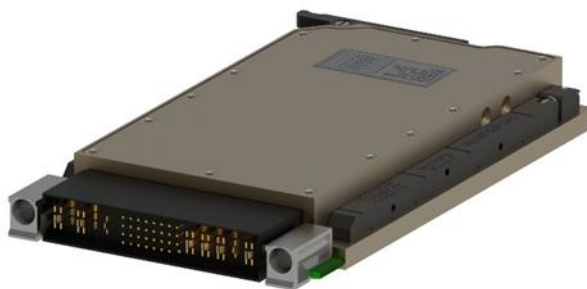

Product Highlight

- Vita62 Compliant
 - SOSA Alignment
 - 600W Steady State
 - EMI Mil-STD-801G
 - Current Share¹
 - NED¹
 - Operational Temperature
-55°C to +85°C (unit Edge)
- Input Options:
- Mil-STD-704
 - Mil-STD-1275 Surges & Transients

Notes:

1. Optional configuration by part number

M2192 Series– DC/DC Power Supply

1. Scope

The M2192 Power supply is a member of Enercon SOSA Aligned VPX product line and is intended to serve at 28V Input DC line to support a total of 600W steady state, under all Line and temperature conditions.

2. Module High Level Specification Details

Enercon Part Number **M2192**

Parameter	Functionality
Form factor	3U VPX, VITA 62 compliant 1" pitch
Cooling	Conduction cooled
Power input	28V Line, Mil-STD-704, Mil-STD-1275E
Power output	12V/50A, 3.3V/15A, 600W Total.
Power Holdup	With M4162 unit.
Management	Tier-II IPMI/46.11 via P0 IPMI-A and (IPMI-B TBD) FPGA based management.
Temperature	-55C – 85C unit Edge (VITA 47.1 Extended CC4)
Weight	Approx 830g

2.1 Special Features

- VITA 62
- Aligned with the SOSA™ Technical Standard
- VITA 47.1 CC4/CCW7 NT4 V3 OS2 C4 AV2 SF1/SF3 CS5
- Up to 600W output power without derating
- 12V Active Current share, 3.3V ACS or PCS
- Remote sense
- Outputs Short Circuit Protection
- Outputs Over Voltage Protection
- Over Temperature Shutdown with Auto Recovery
- Mil-STD-1275E
- Mil-STD-461-G (5μ LISN)
- System Management: protocol per VITA 46.11 (IPMI Tool, ELMA ChM)

3. M2192 Power Supply Operation

M2192 Series– DC/DC Power Supply

3.1 Unit Block Diagram

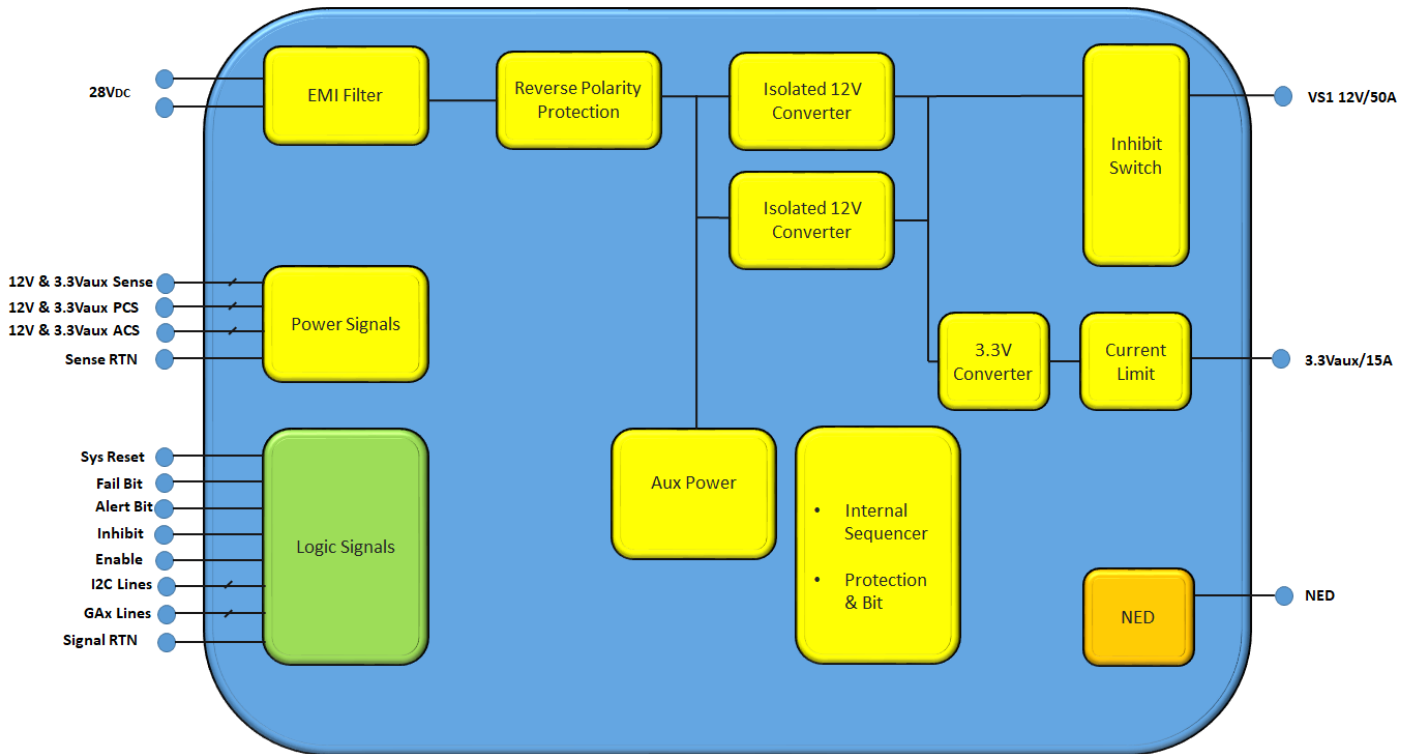

M2192 block diagram

M2192 Series– DC/DC Power Supply

3.2 Electrical Specification

DC Input:

- 18V to 48V DC
Turn-on by Input voltage below 21V.
Turn off after 30Sec under 20V Line
- Work through 12V & 100V 1275E Surges

DC Outputs:

- VS1: 12V / 50A
- 3.3Vaux: 3.3V / 15A

Isolation:

- 200V Input to Output & Chassis.
- 100V Output to chassis

Line Load Regulation

- 12V Output 11.85V to 12.15V
- 3.3V Output 3.28V to 3.42V,
3.25V to 3.45V parallel-PCS.

Efficiency

Up to 87%.

EMC

Mil-STD-461G 5 μ H LISN¹
CE101, CE102, CS101, CS114,
CS115, CS116
Notes: All tests performed with Static resistive Load.

Ripple and Noise

Typical less than 50mV (max 1%)
across 0.1 μ F capacitor with 10 μ F on Load.
Note: under all temperature range, Input voltage 18V to 36V.

System Management Options:

- Simplified IPMI
- IPMC Tier 2
(Tier 3 Upgradable)

Typical Quiescent Current

- Inhibited Output TBD
(28V Input, 3.3Vaux only).
- Disabled Outputs TBD
(28V Input, Outputs Off).

Load Transients

Outputs dynamic response less than 5%
for Load steps 60% - 90%.
Outputs returns to regulation <1mSec.

3.2.1 Protections

Input Current Inrush:

- Bus capacitance \approx 500 μ F.
- Output Turn-on
inrush Input current < 1

Outputs Over Voltage

- 12V Active OVP
- 3.3Vaux 3.9V Zener

Over Load Protection:

Hiccup Over-load / Short Circuit
Protection. Typically, 110%-130% Load.

Input Under /Over Voltage Protection

- Turn-off above 50V.
- Turn-off under 17V steady state.
- Turn-off after 30Sec below 22V.
Note: T.H can be modified.

Over Temperature Protection

Thermal shutdown at Unit
temperature of 90-105 $^{\circ}$ C.
Auto Recovery 90 \pm 5 $^{\circ}$ C (unit
Edge, wedge lock side)

M2192 Series– DC/DC Power Supply

3.3 Environmental Specification.

VITA 47.1 CC4/CCW7 NT4 V3 OS2 C4 AV2 SF1/SF3 CS5

Temperature:

- Operational -55°C to 85°C unit edge, -55°C to 81°C cold wall.
- Exceed Vita 47 CC4.
- Storage -55°C to 125°C
- Designed for 600 Thermal Cycles
Note: Plug-in unit edge surface temperature is measured on the plug-in unit

Altitude:

- Mil-STD-810G Method 500.5 procedure I & II
- Storage / Air Transport: 40kft
- Operation / Air carriage: 70kft

Rapid Decompression

Designed to meet per Vita 47.1

Corrosion Resistance

- Mil-STD-810G, Method 509.5.
- VITA47 Class SF1, SF3
- VITA47 Class SF2 TBD

Fungus

Does not support Fungus growth per Mil-HDBK-454, Guideline 4.

Humidity

- Mil-STD-810G, Method 507, up to 95% RH.
- Optional:100% condensation, consult factory.

Vibration & Shock

- Vita47 Vibration Class V3.
- Vita 47 Operational Shock Class OS2
- Vita 47 Bench Handling Shock (Connector not protected, may be damaged).

Reliability

348,000 Hours,
calculated IAW MIL-HDBK-217F Notice 2
at +65 °C, GF

ESS

Environmental Stress Screening available, please contact factory for details

M2192 Series– DC/DC Power Supply

3.4 Unit Interfaces

3.4.1 Mechanical Interface

Front Panel Connector	Tyco 6450849-7 or equivalent	Main Connector
Mating Connector	Tyco 1-6450869-4 or equivalent	Backplane Connector
Wedge Locks	WAVETHERM SW7-475-250-300-6332-BA or Equivalent	
Key 1	0°	
Key 2	135°	
Back Panel USB-C Port	N/A	FPGA Programing Port

Table 3.4.1-1 Unit Mechanical Interface

M2192 Series– DC/DC Power Supply

3.4.2 Functions and Signals

Signal Name	Type	Description
FAIL*	Output Open Drain	Indicates to other modules in the system that a failure has occurred in one of the outputs. ^{1,2} Normally Open.
SYSRESET*	Output Open Drain.	Indicates to other modules in the system that an output voltage is not in its nominal range. ^{1,2} Normally Open.
INHIBIT*	Input	Controls 12V Output. ^{1,3}
ENABLE*	Input	Controls 12V, 3.3V Outputs. ^{1,3}
NED	Output	NED event detector output. Normally Low, goes high and Latch during Event. Internal 2K pullup to 3.3V
NED RETURN	Output	NED Return. ¹
GA0*, GA1*	Input	System addressing per VITA46. ¹
SCL_A, SDA_A	Bi-Direction	Primary I2C lines. ¹
SCL_B, SDA_B	Bi-Direction	Secondary I2C lines. ¹
SYNC IN	Input	External Clock for PWM Synchronization. ¹
PO_SENSE	Output	Output Sense line for voltage compensation. ¹
SENSE RETURN	Output	Output Sense return for voltage compensation. Common line for all outputs.
SHARE	Bi-Directional	Current share pins
3.3V AUX ACS	Bi-Directional	Additional Current share pin to support 3.3VAux Active current share.
SIGNAL RETURN	Passive	Return path for all signals, refers to Output Power ground.

Notes

- 1 Refers to SIGNAL RETURN
- 2 See para 3.5.3 for additional information
- 3 See para 3.5.2.1 for additional information

3.5 Power Detailed Description

3.5.1 Input Voltage

3.5.1.1 Operational Input Range

Unit will be fully operational under all steady state condition from 18V up to 50V line and work through Mil-STD-1275E 12V IES, 16V Cranking surge and 100V transients.

Turn -on voltage is under 21V volt, before going into normal steady state.

Unit will work for a duration of 30Sec once input voltage is lower than 20V.

3.5.1.2 Transient Response

Power supply is designed to have a good transient response for input voltage transient

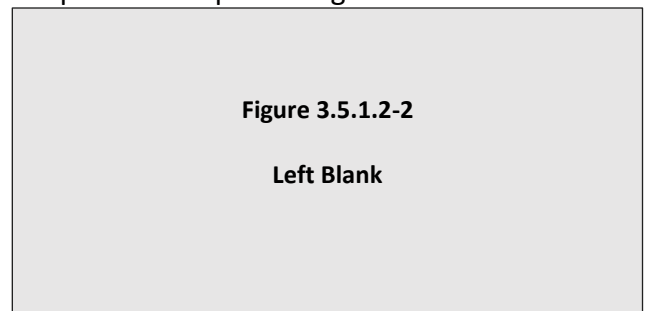
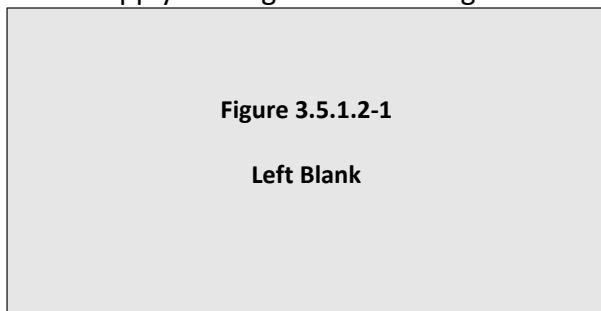

3.5.1.3 Voltage Distortion

Design to meet Mil-STD-704D LDC103

3.5.1.4 Input Redundancy

M2192 can support parallel operation while fed from two independence power sources.

Note: this configuration does not guarantee output redundancy. Both input source should be active at the same time, otherwise it can result in over voltage on 3.3VAux.

3.5.1.5 Input Voltage Rise Time

There is no limitation on Input voltage rise time, contactor connection is supported.

3.5.1.6 Inrush Currents

Turn-on inrush current can be divided into two categories:

Bus Charge Inrush, input current is a function of input voltage rise time, charging the 500 μ F capacitance.

Outputs Turn-on Inrush, Input current while outputs turn-on is typically less than 1A above the steady state current. See Figure 3.5.1.6-1.

Figure 3.5.1.6-1 Outputs Tur-on Inrush.

Kept Blank

3.5.2 Outputs

3.5.2.1 Outputs Controls: Enable & Inhibit Signals

Outputs are controlled by Enable and Inhibit Signals per VITA 62 definition.

See Table 3.5.2.1-1

INHIBIT*	Low	Low	High	High
ENABLE*	Low	High	Low	High
12V Output	OFF	OFF	ON	OFF
3.3V Aux Output	ON	OFF	ON	OFF

Table 3.5.2.1-1 Outputs Truth table per Signal Status

3.5.2.2 Output Power

Standard configuration will support 12V/50A and 3.3VAux/15A with up to 2mF capacitance on each output.

No Power derating is required for current share application.

Note: for extended output capacitance, please contact factory.

3.5.2.3 Voltage regulation and Ripple

Voltage regulation and ripple are measured at sense point location. Limits are under all Line, Load, and Temperature operational range. Limits are also given for ACS (12V, 3.3VAux optional) and 3.3VAux PCS.

Voltage is measured at the connector output with sense line shorted to output at connector point

Statuses	12V Output Limits	3.3VAux Output Limits
Single Unit	11.85V – 12.15V	3.28V – 3.42V
Current Share (3.3VAux ACS)	11.85V – 12.15V	3.28V – 3.42V
Current Share (3.3VAux PCS)	11.85V – 12.15V	3.25V – 3.45V

Table 3.5.2.4-1 Outputs Voltage Regulation under all operational Line, Load and Temperature conditions

Note: The limits above are within all Line, Load and Temperature steady state conditions

Statuses	12V Output Limits	3.3VAux Output Limits
Single Unit	120mV	50mV
Current Share (3.3VAux ACS)	120mV	50mV
Current Share (3.3VAux PCS)	120mV	50mV

Table 3.5.2.4-2 Outputs Voltage Ripple under 18V to 36V line, under all Loads and Temperatures

Notes:

- Limits for 18V-36V Input, under all Loads and Temperature conditions
- Ripple is measured on load after 3-feet harness across 0.1μF capacitor with 10 μF on Load (20MHz BW).

M2192 Series– DC/DC Power Supply

3.5.2.4 Turn-on & Sequencing

Standard configuration 12V rises before 3.3VAux.
Please contact Factory for a different sequencing

3.5.2.5 Sense Connection

Sense lines are provided for 12V and 3.3VAux outputs for line voltage drop. Each output has its own

Figure 3.5.2.7-1 (3 units) current share Turn-on

Kept Blank

Figure 3.5.2.7-2 (3 units) Output Ripple

Figure 3.5.2.5-1. Output's sense connection

3.5.2.6 Dynamic Response

Typical performance of 5% output response during a 60% to 90% load dynamic response

3.5.2.7 Current Share

Current share allows the user to connect two or more M2192 units in parallel for doubling the output power of each rail. No derating is required for current share configuration.

M2192 Series– DC/DC Power Supply

Current share typically provides up to 1-3A balance between units. An example of 3 VPX units, each providing about 50A are shown on Figures 3.5.2.7-1 through 2.

The 12V output uses Active Current Share topology. By comparing the actual current between paralleled units, the unit can provide accurate share balance between outputs with very low susceptibility to power traces and sense connection and without the need for voltage drop. The 3.3VAux output supports both Passive Current share with voltage drop or ACS with an additional U.D pin.

During a fault condition with either ACS or PCS both outputs will hiccup synchronously to support synchronous turn on while under load.

Recommended current share connection is given on *Figure 3.5.2.7-3*

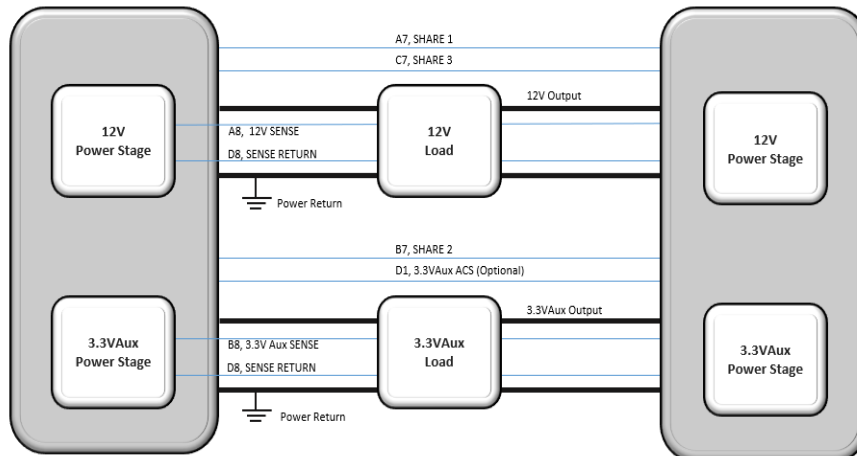

Figure 3.5.2.8-3 current share connection.

Note: For best current share balance, make sure both outputs SENSE lines are connected to a single load point to insure V_{out} of each outputs is as close as possible to the other.

Note:

- Current share is an optional configuration

M2192 Series– DC/DC Power Supply

- For 12V output, both A7, C7 need to be connected.
- Typical current share starts at load above 10% of each unit's max load
- No derating is required
- Current share is not a guarantee for redundancy, some failures (E.g. short on output) will result in a failure of both units.
- During overload condition, both relative outputs will be synchronized with their hiccup to allow Turn-on into full load once the fault condition is removed.
- Multiple current share units are optional.

3.5.2.8 Short Protection

Both 12V and 3.3VAux outputs have an indefinite hiccup for over-Load / short circuit protection. The over-load hiccup threshold is 110%-120% of nominal current. Output will automatically recover after removal of fault condition.

A short on 3.3VAux rail will not affect the 12V Output, a short on the 12V rail will cause the 3.3VAux to hiccup as well.

While output is at hiccup mode, current during on-time may exceed 140% of max current

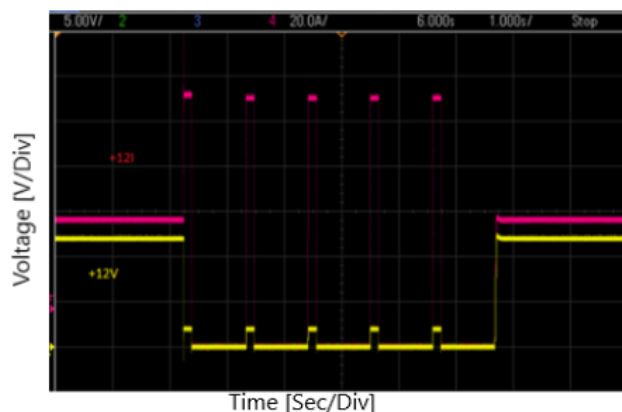

3.5.2.9 Over Voltage Protection

12V output has an active Over Voltage Protection. An O.V. condition caused by internal failure will cause the output to Shutdown with Auto-recovery. Shutdown at 13.2-13.6V, recovers 12.4-12.6V.

3.3VAux Output: 3.9V Output Zener.

Figure 3.5.2.8-1 Typical 12V Output hiccup and recovery after short

3.5.2.10 Hold-up

Requires M4162 unit.

Contact factory for choosing the correct part number.

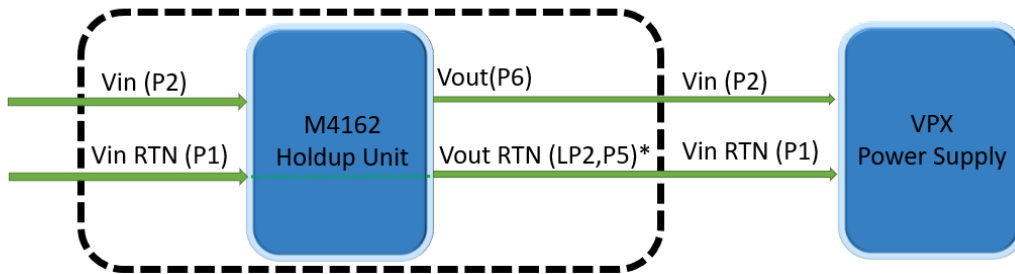

3.5.3 Signals

3.5.3.1 Fail bit & SYSTEM RESET

Unit has two dedicate Fault signals:

Fail BIT: Indicates that one of the power supply outputs is out of its range, in respect to the expected value depending on Inhibit & Enable status.

Open drain output (Per VITA 65), Normally Open and goes Low during Fail event.

SYSTEM RESET: Indicates that one of the power supply outputs is out of its nominal range.

Open drain output (Per VITA 65), Normally Open and goes Low when output is out of nominal range.

Note: for the M2192 this BIT standard configuration is as “Output”.

3.5.3.2 SYNC IN

This pin can be used to synchronize the power supply switching frequency to an external clock.

Standard switching frequency with no Sync In signal applied is 220kHz \pm 5%. When configured to use Sync, the unit will sync to a signal between 200kHz and 300kHz \pm 5%. The square wave must be at 3.3V CMOS standard logic levels with a duty cycle between 20% and 80%. The M2192 will sync after 32 cycles within tolerance of external clock. The unit will revert to its internal clock frequency upon any out of specification clock cycles and will need 32 good cycles to resync to the external clock.

Contact factory to add Sync_In functionality and to customize its configuration values.

Notes:

1. Function is optional, please contact factory.
2. When not used, keep open.
3. Deviating from original frequency may affect efficiency.

3.5.3.3 NED

During NED Event, the Unit will turn-off the 12V and 3.3VAux Output.

NED output is Normally Low and will Latch High after NED detection.

Important Notes:

1. NED circuit operation during event needs to be verified by the user.
2. Internal Aux circuits are designed to stay operational after event.
3. Power supply proper operation after event need to be verified by the user.
Enercon Can support NED analysis, please contact Factory.

Built In Tests

For proper operation, the unit has Built In Test circuit, which continuously monitors Unit's internal functions, such as: Input Voltage, Internal Aux voltage, Temperature, Output voltages and controls accordingly a proper Turn-on and Turn-off Sequence.

Turn on: verification that all parameters are within tolerance and all Aux voltage are stable before starting the output Turn-on sequence.

Continuous: Monitors all critical parameters and initiates a controlled Turn-off sequence when required.

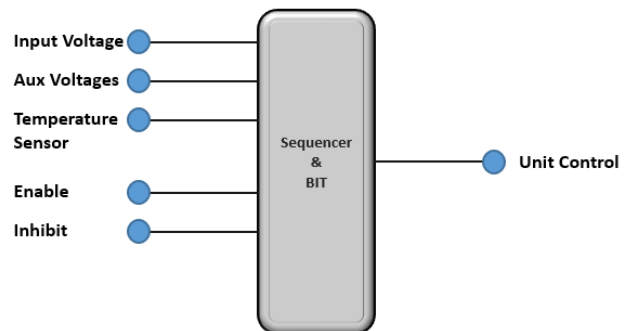

M2192 Series– DC/DC Power Supply

3.5.4 Thermal Management

Operational Temperature range is -55°C to +85°C on the surface of the edge that contacts the rack/enclosure. The contact surface on the rack needs to be at a lower temperature to account for thermal resistance between the unit and the chassis/cold plate. The M2192 wedge locks are defined as 0.1 °C/W Resistance per Card Edge. The thermal design of the unit will provide a balanced power dissipation between both sides of the unit.

The unit has two thermal sensors.

I2C thermal sensor for 46.11. located at unit hottest spot.

Analog Thermal Sensor for protection and shutdown. Shutdown temperature would be between 90°C to 105°C on the unit’s edge, load dependant.

No power derating is required across the operational temperature range

3.5.5 Efficiency

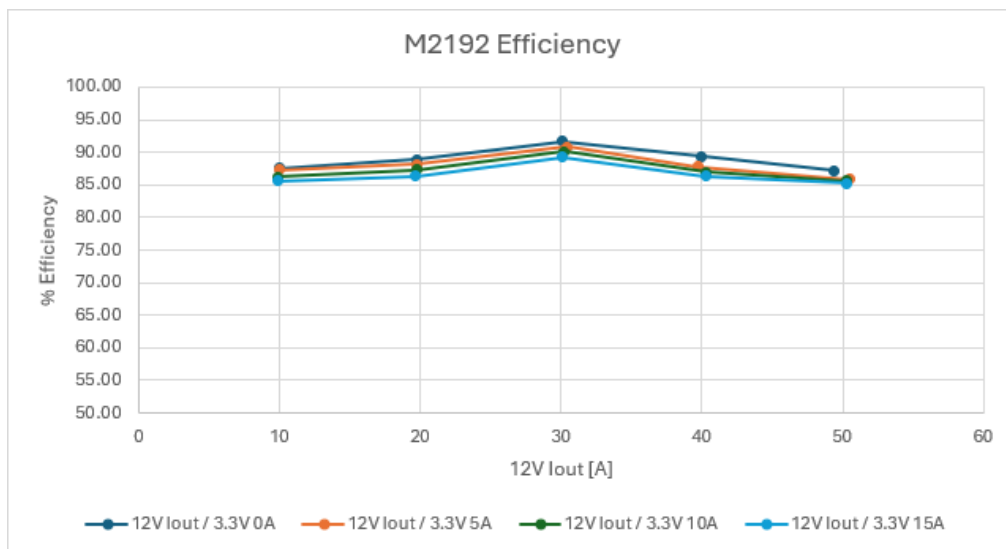

Figure 3.5.7-1. Typical efficiency, room temperature

M2192 Series– DC/DC Power Supply

3.5.6 EMI

EMI Test per Mil-STD-461G for CE102

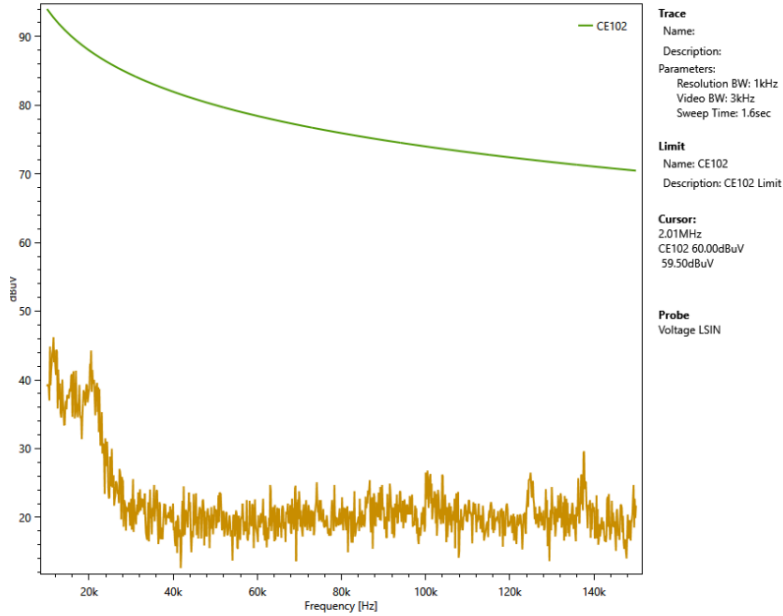

Figure 3.5.7-1. CE102 Full Load, 10KHZ to 150KHZ

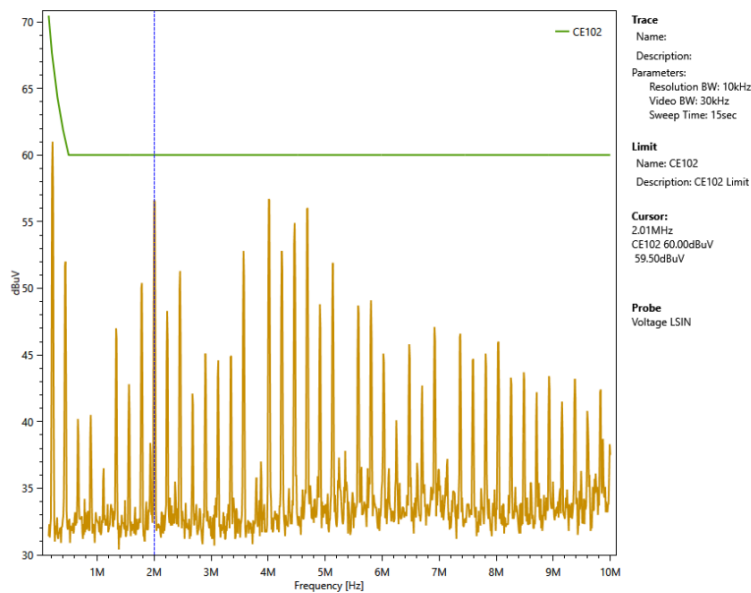

Figure 3.5.7-2. CE102 Full Load, 150KHZ to 10MHZ

3.6 System Management

3.6.1 Electrical Interface

Pullups	20KΩ
Capacitance	100PF
Vcc	3.3V
USB-C Port	N/A

3.6.2 Communication Protocol

The M2192 can be configured to one of the two I2C communication protocols: 46.11 Tier 2 IPMC or Simplified I2C.

Slot location, for both options, is defined per VITA62. See table 3.7.2-1.

The following data sensors are available:

Output Current sensors: Max error of +/-5% or up to +/-1A (the bigger of the two)

Output Voltage sensors: Max error up to +/-0.2V

Input Voltage sensors: Max error up to +/-1.5V

Temperature sensors: ±5C (Internal measurement).

Slot Number	A6	A5	A4	A3	A2	A1/GA1*	A0/GA0*	Hardware Address	IPMB
Slot0	0	1	0	0	0	0 / U	0 / U	20	40
Slot1	0	1	0	0	0	0 / U	1 / G	21	42
Slot2	0	1	0	0	0	1 / G	0 / U	22	44
Slot3	0	1	0	0	0	1 / G	1 / G	23	46

Table 3.6.2-1 Address Space

Note: A0÷A6 represent Firmware address and GAx represent the physical Geographical Address.

U = Unconnected; signal is pulled-up on the unit and result as logic "0"

G = Biased to Ground on the Backplane; results in a logical "1"

M2192 Series– DC/DC Power Supply

3.6.2.1 IPMC, 46.11 Tier2

The M2192 design to support both ELMA’s ChM and IPMITOOL System Interface. Adjustments can be made to support custom ChM configurations.

Sensor ID	Sensor Type	Name
00	F0h	FRU State Sensor
01	F1h	System IPMB Link Sensor
02	F2h	FRU Health Sensor
03	02h	FRU Voltage Sensor
04	F3h	FRU Temperature Sensor
05	F4h	Payload Test Results Sensor
06	F5h	Payload Test Status Sensor
07	02h	VS1 Voltage
08	03h	VS1 Current
09	02h	3.3VAux Voltage
10	03h	3.3VAux Current
11	01h	Input Voltage
12	02h	Analog Temperature
N/A	N/A	Device Locator Record
N/A	N/A	Device Management

Table 3.6.2.1-1. Sensor Allocation

IPMITOOL Command
SDR List
Sensor List
Fru Print
SEL List
SEL Clear

Table 3.6.2.1-2. Supported IPMITOOL Commands

IPMI Command	NetFn	Group ID	CMD
Get Device ID	APP	N/A	01h
Get Self-Test Results	APP	N/A	04h
Get FRU Inventory Area Info	Storage	N/A	10h
Read FRU Data	Storage	N/A	11h
Set Event Receiver	S/E	N/A	00h
Get Event Receiver	S/E	N/A	01h
Get Device SDR info	S/E	N/A	20h
Get Device SDR	S/E	N/A	21h
Reserve Device SDR Repository	S/E	N/A	22h
Get Sensor Reading	S/E	N/A	2Dh
Get VSO Capabilities	Group Extension	VSO (03h)	00h
Set IPMB State	Group Extension	VSO (03h)	09h
Get Device Locator Record ID	Group Extension	VSO (03h)	0Dh
Fru Control Capabilities	Group Extension	VSO (03h)	1Eh
Get FRU Address Info	Group Extension	VSO (03h)	40h

Table 3.6.2.1-3. Supported RAW IPMI Commands

Sensor Name	Parameter	Upper	Upper	Upper	Lower	Lower	Lower
-------------	-----------	-------	-------	-------	-------	-------	-------

M2192 Series– DC/DC Power Supply

		Non-Recoverable Threshold	Critical Threshold	Non-Critical Threshold	Non-Critical Threshold	Critical Threshold	Non-Recoverable Threshold
VS1 12V	Voltage	13V	12.8V	12.6V	11.6V	11.4V	11.2V
	Current						
3.3VAux	Voltage	4.2V	4.0V	3.8V	3V	2.8V	2.6V
	Current	24A	22A	20A			
Temperature	Temperature	115°C	110°C	105°C	-55°C	-60°C	-60°C
Vin	Voltage						

Table 3.7.2.1-4. Sensors Thresholds

Note:

1. Threshold levels can be updated, please consult Factory.
2. Temperature measurements are taken at unit hottest spot and are load dependent.
4. Unit temperature shutdown, executed by a sperate sensor in may occur before Upper Non-Recoverable Threshold.

Revision Updates:

Units may have Firmware updates, please refer to specific Dash numbers catalog Page for firmware update information.

M2192 Series– DC/DC Power Supply

3.6.2.2 Simplified I2C Communication

This communication protocol is optional when 46.11 compatible ChM is not used.

Communication supports the following commands.

S	Slave Address	R/W	A	Command	A	Check sum	A	P
	A6:A0	0	0	Hex 21	0	DF Hex	0	

S	Slave Address	R/W	A	DATA	A	DATA	A	DATA	A	...	DATA	A	Check sum	N/A	P
	A6:A0	1	0	D7:D0	0	D7:D0	0	D7:D0	0	...	D7:D0	0	D7:D0	1	

S-Start

P-Stop

Master Transmit	Unit Transmit
-----------------	---------------

Response Byte #	Data Type	Meaning	Interpretation	Reading Range
0	U Integer, MSB First	Echo of Command		21 Hex
1		N/A		00 Hex
2-3	S Integer, MSB First	Temperature -55C to 120C	T(C)=+/- 7bit Dec	-55°C to 125°C
4-5	U Integer, MSB First	12V VS1 Voltage	V(out) = Data · m ₂	20.48V
6-7	U Integer, MSB First	3.3V VS2 Voltage	V(out) = Data · m ₂	20.48V
8-9	U Integer, MSB First	N/A	N/A	N/A
10-11	U Integer, MSB First	N/A	N/A	N/A
12-13	U Integer, MSB First	N/A	N/A	N/A
14-15	U Integer, MSB First	N/A	N/A	N/A
16-17	U Integer, MSB First	12V VS1 Current	V(out) = Data · m ₃	80A
18-19	U Integer, MSB First	3.3V VS2 Current	V(out) = Data · m ₃	20A
20-21	U Integer, MSB First	N/A	N/A	N/A
22-23	U Integer, MSB First	N/A	N/A	N/A
24-35	U Integer, MSB First	N/A	N/A	N/A
26-27	U Integer, MSB First	N/A	N/A	N/A
28-29	U Integer, MSB First	Reserved	00Hex	
30-31	U Integer, MSB First	Reserved	00Hex	
32-51	Character String (ASCII)	Part Number	M4054-xxx* (Note1)	20 Characters
52-53	Decimal, MSB First	Serial Number, 2MSB Dig	X,X Dec (Note2)	Optional
54-55	Decimal, MSB First	Serial Number, 2LSB Dig	X,X Dec (Note2)	Optional
56-57	Decimal, MSB First	Date Code	Week, Year (Note3)	Optional
58-59	Character String (ASCII)	Hardware Rev	B01 & B02 Boards (Note4)	2 Characters
60-61	Decimal, MSB First	Firmware Rev	X,X,X,X Dec (Note5)	4 digits
62	U Integer, MSB First	Reserved		AA Hex
63	U Integer, MSB First	Zero Checksum	Value required to make the sum of bytes 0 to 62 added to a multiple of 256	

Note:

M₂ = 20.48/65535

M₃ = 80/65535

M₄ = 20/65535

*Matching unit part number

M2192 Series– DC/DC Power Supply

3.7 Pinout

<i>Pin Number</i>	<i>Pin Name (12V Only)</i>	<i>Function</i>
P1	-DC_IN/ACN	28V Return
P2	+DC_IN/ACL	28V
LP1	CHASSIS	CHASSIS
P3	+12VDC (VS1)	12V Output
P4	POWER_RETURN	Output Return
P5	POWER_RETURN	Output Return
LP2	3.3V_AUX	3.3V Output
P6	+12VDC (VS1)	12V Output
A8	SENSE, +12VDC	12V Sense
B8	SENSE, 3.3V_AUX	3.3V Aux Sense
C8	SENSE, +12VDC	N.C
D8	SENSE_RETURN	Sense Return
A7	SHARE_1	12V Current Share
B7	SHARE_2	3.3V Aux Current Share
C7	SHARE_3	12V ACS
D7	SIGNAL_RETURN	Signal Return
A6	SM2	I ² C SCL B
B6	SM3	I ² C SDA B
C6	N Reserved C.	D.N.C.
D6	SYSRESET*	SYSRESET*
A5	GA0*	GA0*
B5	GA1*	GA1*
C5	SM0	I ² C SCL A
D5	SM1	I ² C SDA A
A4	Reserved	D.N.C.
B4	Reserved	D.N.C.
C4	Reserved	D.N.C.
D4	Reserved	D.N.C.
A3	SYNC_IN (UD0)	External Sync Clock
B3	Reserved	N.C.
C3	NED	NED Output
D3	NED_RETURN	NED Return
A2	VBAT	D.N.C.
B2	FAIL*	FAIL*
C2	INHIBIT*	INHIBIT*
D2	ENABLE*	ENABLE*
A1	SYNC_OUT (UD1)	N.C.
B1	NVMRO (UD2)	N.C.
C1	GA2* (UD3)	N.C.
D1	UD4	3.3V Aux ACS

M2192 Series– DC/DC Power Supply

3.8 Mechanical SCD

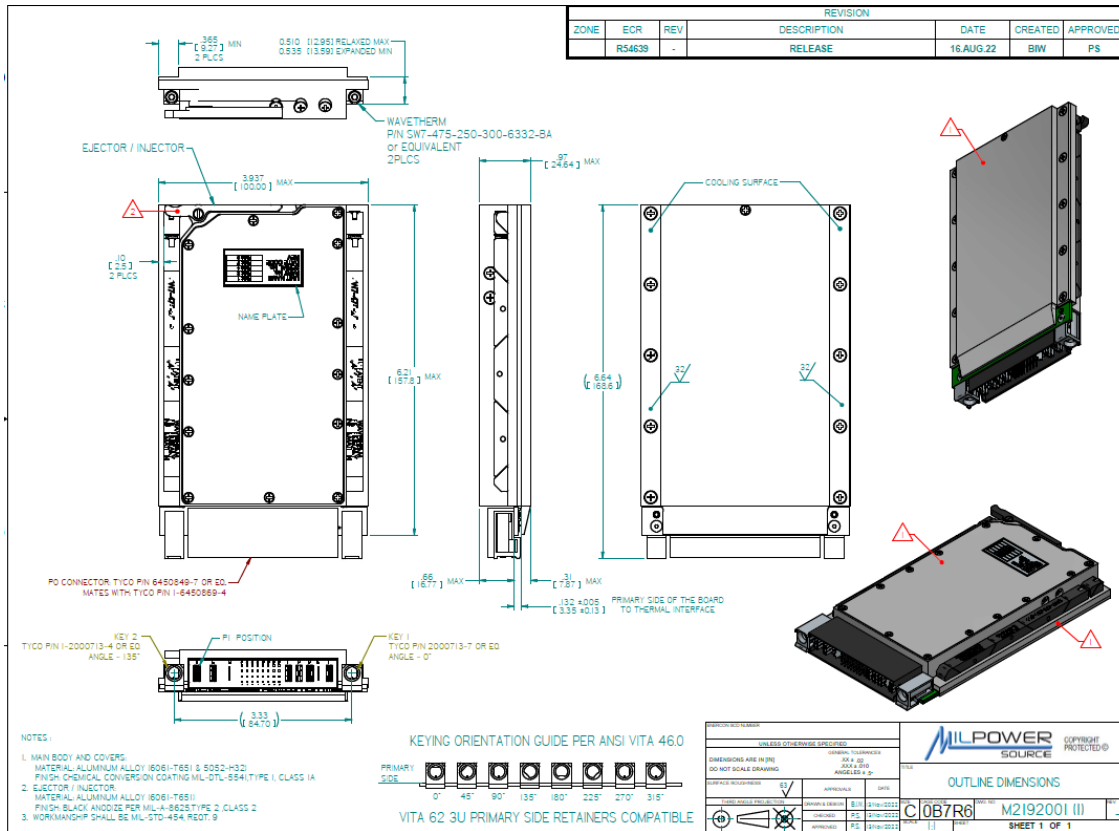

Notes

Dimensions are in Inches[mm]
Weight Approx 830g