

# M2703 SERIES

## 3-PHASE AC/DC POWER SUPPLY



### PRODUCT HIGHLIGHTS

- 3-PHASE AC/DC POWER SUPPLY
- HIGH EFFICIENCY
- SINGLE OUTPUT
- UP TO 2.5 kW

## M2703 SERIES 3-PHASE AC/DC POWER SUPPLY

### Applications

Military, Ruggedized, Telecom, Industrial Power Supply

### Special Features

- Compact size
- High efficiency
- Wide input range
- Input / Output isolation
- Fixed switching frequency (approx. 400 kHz)
- Logic Inhibit
- EMI filters included
- Limited Inrush Current
- Indefinite short circuit protection with auto-recovery
- Over temperature shutdown with auto-recovery

### Environmental Conditions

Designed to Meet MIL-STD-810F

#### Temperature

Methods 501.4 & 502.4

Operating:  $-55^{\circ}\text{C}$  to  $+85^{\circ}\text{C}$  (at baseplate)

Storage:  $-55^{\circ}\text{C}$  to  $+125^{\circ}\text{C}$  (ambient) Vibration

#### Vibration

Method 514.5

Procedure I, Category 24

General minimum integrity exposure

IAW Figure 514.5C-17

1 hour per axis.

#### Altitude

Method 500.4

Procedure I – Storage/Air transport:  
up to 70,000 ft. (non-operational)

Procedure II – Operation/Air Carriage:  
up to 40,000 ft. (operational) Shock

#### Shock

Method 516.5

Procedure I

20 g / 11 ms terminal peak sawtooth shock pulse

#### Humidity

Method 507.4

Up to 95% RH

#### Salt Fog

Method 509.4

### Reliability

150,000 hours, calculated per  
MIL-STD-217F at  $+85^{\circ}\text{C}$  baseplate, Ground Fixed.

### Electrical Specifications

#### AC INPUT

##### Nominal voltage:

3-Phase 115  $V_{\text{RMS,L-N}}$  103 to 125Vac/ 400 Hz

##### Input Transient Protection:

No damage when expose to transients IAW MIL-STD-704F transients.

##### Efficiency: 90%, Typical

Power Factor: Minimum 85% from 50% load

EMC: Designed to meet MIL-STD-461F CE102, CS101, CS114, CS115, CS116, RE102, RS101, RS103 with external filter and shielded cable.

##### Isolation:

Input to Output: 500  $V_{\text{DC}}$

Input to Case: 500  $V_{\text{DC}}$

#### DC OUTPUT (floating)

Voltage range: 100 to 320  $V_{\text{DC}}$  Current range: no load up to 20 A

Line/Load regulation: Less than  $\pm 1\%$  (0 to 100% load,  $-55^{\circ}\text{C}$  to  $+85^{\circ}\text{C}$ )

Ripple and Noise: 100  $\text{mV}_{\text{p-p}}$ , typical (max. 1%)

##### Current limiting:

Continuous protection for unlimited time

##### Over-voltage protection:

Passive tranzorb on output. Over temperature protection:

Shutdown if baseplate temperature exceeds  $+105^{\circ}\text{C} \pm 5^{\circ}\text{C}$ ; Automatic recovery upon baseplate cooldown to below  $+95^{\circ}\text{C} \pm 5^{\circ}\text{C}$

##### Isolation:

Output to Case: 5

**Pin Assignment**

**CONNECTOR J2 (INPUT)**

Connector type: M24308/24-38F or eq.  
Mating connector: M24308/2-2F or eq.

Function	Pin No.
PHASE A	7, 14, 15
PHASE B	4, 5, 12
PHASE C	2, 9, 10
CHASSIS	1

**CONNECTOR J1 (OUTPUT)**

Connector type: M24308/23-38F or eq.  
Mating connector: M24308/4-2F or eq.

Function	Pin No.	Polarity
V <sub>OUT</sub>	4, 5, 11, 12	+
V <sub>OUT</sub> RTN	7, 8, 14, 15	-
INHIBIT	3	+
INHIBIT RTN	2	-
PWR GOOD	10	+
PWR GOOD RTN	13	-

## M1912 Series– AC/DC Power Supply

### Functions and Signals

#### **INHIBIT signal (connector J1, pin 3)**

The **INHIBIT** signal is used to turn the power supply ON and OFF. To turn the power supply ON, leave pin 3 open.

To turn the power supply OFF, short pin 3 to pin 2.

If not used, leave pin 3 unconnected.

This signal is referenced to **INHIBIT RTN (connector J1, pin 2)**

#### **PWR GOOD signal (connector J1, pin 10)**

The **PWR GOOD** signal indicates the status of the output voltage.

When output voltage rises above  $95\% \pm 5\%$  of its nominal value, pin 10 will be pulled down to pin 13 through a  $49.9\ \Omega \pm 1\%$  resistor and a phototransistor.

When output voltage falls below  $90\% \pm 5\%$  of its nominal value, pin 10 will be in high impedance mode. If not used, leave the signal unconnected.

This signal is referenced to **PWR GOOD RTN (connector J1, pin 13)**

Both pins 10 and 13 are isolated from all other parts of the circuitry.

### Typical Connection Diagram

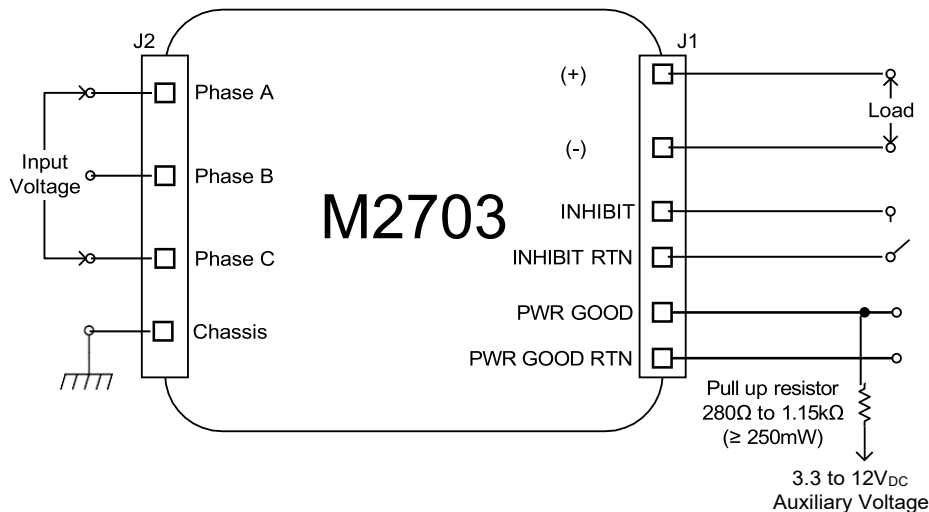

**Note:** PWR GOOD pull-up resistor and auxiliary voltage shown in this diagram are typical values. The system designer must select the actual values such that no damage can occur to the internal components of the power supply – *consult factory for more information.*

**M1912 Series– AC/DC Power Supply**

**Outline Drawing**

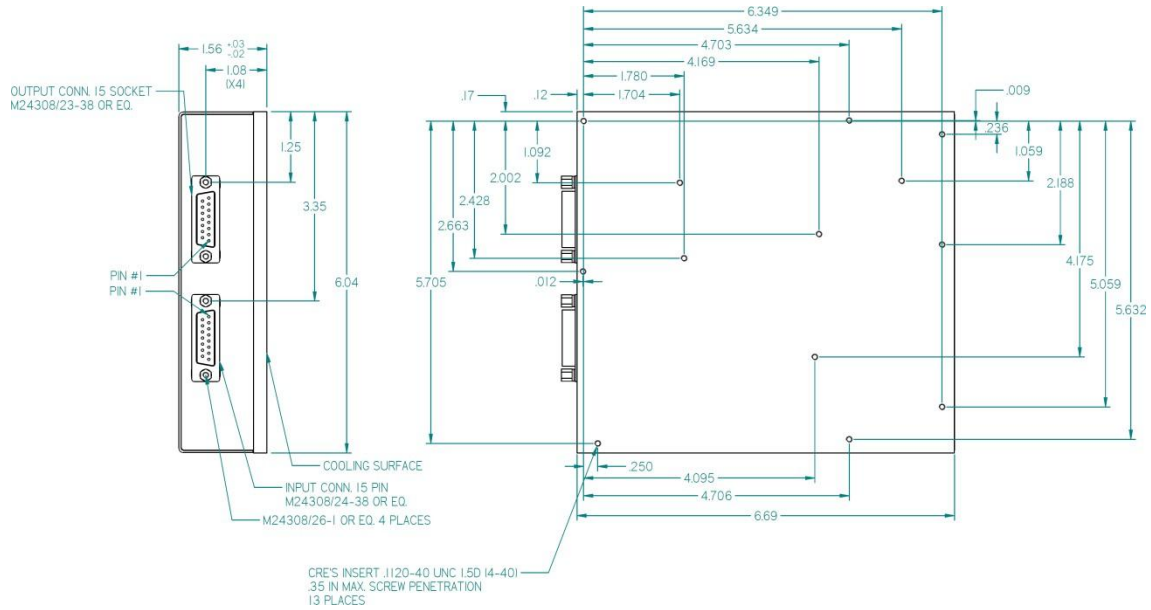

**Heat Dissipation Surface Area**

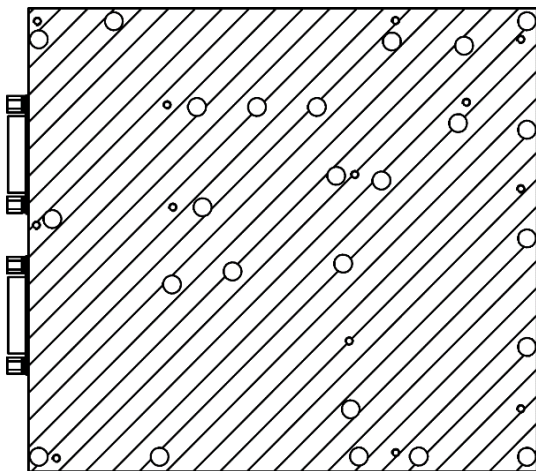

Surface area:  
39.2 sq. in.  
[25 290 sq. mm]

**Notes**

1. Dimensions are in Inches
2. Tolerance is:  
.XX  $\pm$  .02 IN  
.XXX  $\pm$  .01 IN
3. Weight: Approx. 4.2 lbs. [1.9kg]

**Note: Specifications are subject to change without prior notice by the manufacturer**