

# M2781-106

NON-ISOLATED, AC-DC SUPPLY (GCU)  
FOR PERMANENT MAGNET GENERATORS

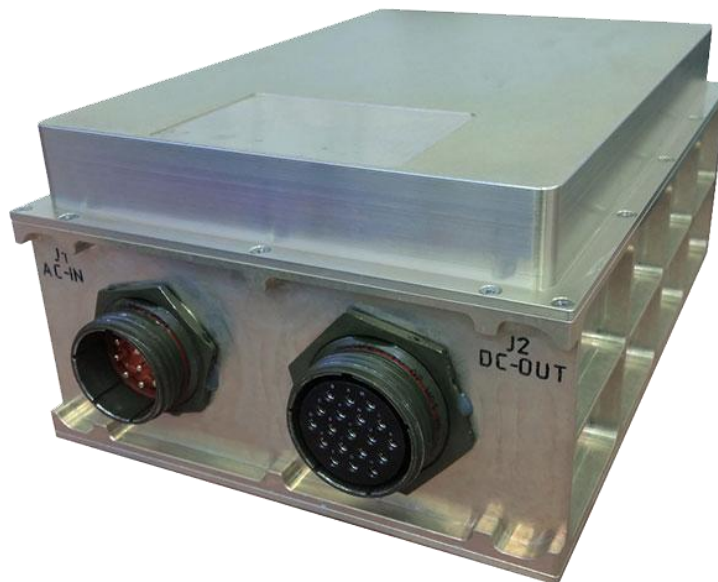

## PRODUCT DESCRIPTION

The M2781-106 is a 2.8KW AC to DC power supply that when fed from the 3-phase, variable-voltage and frequency output of a suitable PMG provides a regulated, filtered and protected 28 VDC output. The M2781-106 is composed of a 3-phase input Bridge-rectifier followed by a wide input-range, high-efficiency switching regulator. The 28VDC Output of the M2781-106 is normally off and turns only when the Enable input signal is active (High).

## 1. GENERAL

### 1.1. Special Features

- 3-PHASE WIDE-RANGE AC INPUT (30 TO 140VAC DELTA)
- 28VDC/2.8KW OUTPUT
- FULLY PROTECTED AND FILTERED
- 2 UNITS CAN BE PARALLELED (CURRENT SHARE)
- ENABLE INPUT AND BIT OUTPUT
- BASEPLATE COOLED

### 1.2. Applicable Documents

The following documents form part of this Specification to the extent specified herein.

|              |  |
|--------------|--|
| MIL-STD-704D | Aircraft Electrical Power Characteristics.   |
| MIL-STD-461F | Requirements for the Control of Electromagnetic Characteristics of Subsystems and Equipment. |
| MIL-STD-810G | Environmental Engineering Considerations and Laboratory Tests.                               |
| M2781006     | Outline Dimensions Drawing   |

## 2. PERFORMANCE

### 2.1. Input Power

The voltage waveform of a typical PMG, when fully loaded by the M2781-106, is highly distorted with a crest factor considerably lower than the theoretical 1.414. Therefore, in order to avoid ambiguities, the minimum input voltage of the M2781-106 is specified herein in terms of the rectified voltage that the PMG provides when measured on the DC terminals of a 3-phase bridge rectifier loaded by a resistive-capacitive load.

#### 2.1.1. Absolute Maximum Voltage

The peak rectified voltage should not exceed 220V. (Assuming a crest factor of 1.414, the 220Vdc is equivalent to a phase-to-phase voltage of 155Vrms). The M2781-106 will not suffer any damage and will remain safe with any input voltage between 0 to 220Vdc. Exceeding 220Vdc, even momentarily, may damage the unit.

## M2781-106 - 28VDC/2.8KW AC to DC Power Supply

### 2.1.2. Operating Input Voltage

The M2781-106 provides full performances when the input (rectified) voltage is between 39Vdc to 200Vdc. (Assuming a crest factor of 1.414, the 200Vdc is equivalent to a phase-to-phase voltage of 141Vrms).

## 2.2. Output Power

### 2.2.1. Power Rating

The M2781-106 provides full performances for any load between no-load to 2.8KW. For Base plate temperature above 75 °C the maximum load should be derated linearly to 1,500 W at 85 °C (130 W/°C).

### 2.2.2. Output Voltage

The steady-state output voltage for any load between no-load to 2.8KW, at any input voltage between 39Vdc to 200Vdc will be within the range of 28.0±0.5Vdc for the entire operating temperature range.

### 2.2.3. Output Ripple

The AC ripple on the M2781-106 output voltage when measured on a resistive load with load capacitance of 10 µF or higher, will not exceed 0.3 Vrms.

## 2.3. Protections

### 2.3.1. Overload and Short Circuit Protection

The M2781-106 is protected from overload up to a full short on its output for an unlimited duration. When overloaded the M2781-106 actively limits its output current to 130±25Amp. If a load attempts to exceed the current limit, the M2781-106 will reduce the output voltage such that the current limit will not be exceeded (see Fig. 1). Upon removal of the overload condition the output will automatically recover to full performances.

### 2.3.2. Overvoltage Protection

The M2781-106 employs two independent overvoltage protection circuits. The first is an electronic circuit that in case of a failure of the control circuit of the M2781-106 that causes the output voltage to exceed 32Vdc disables the 28VDC output and keeps it off (latching) until input power is removed, or the Enable input is recycled off and then back on. This circuit will not trip if the overvoltage is imposed on the M2781-106 output by an external source. The second overvoltage protection is a crow-bar circuit that trips and shorts the 28VDC output if its voltage exceeds 33.5V for any reason. Once the crowbar trips and shorts the output, it will latch and will reset only when power is

## M2781-106 - 28VDC/2.8KW AC to DC Power Supply

removed from the M2781-106. The overvoltage protection circuits will not trip by any input voltage transients (as long as they do not exceed 220V) or by any load transients (including load-removal). The overvoltage protections are intended to prevent failure propagation and protect the user from a failed M2781-106. Triggering the overvoltage protection by using an external source to impose an overvoltage on the M2781-106 output, may damage the M2781-106.

### 2.3.3. Over Temperature Protection

The M2781-106 contains an Over Temperature Protection (O.T.P.) that in case of a cooling failure (namely baseplate temperature exceeding +85 °C) turns the M2781-106 off. Once tripped, the O.T.P. will reset (automatically) when the baseplate temperature drops to below +75 °C.

### 2.4. Isolation

The input and output of the M2781-106 are isolated from the chassis ground (>10 M $\Omega$  @ 500 V<sub>DC</sub>) but not from each other. Any circuit connected to the same AC source (the PMG winding) that the M2781-106 is connected to, must be galvanically isolated from chassis ground and from the DC output of the M2781-106. **Failure to maintain this isolation may damage the load and/or the M2781-106.**

### 2.5. Efficiency and Power Dissipation

The efficiency of the M2781-106 at full load is higher than 88% (dissipating less than 382 W). The power dissipation of the M2781-106 for any operating conditions (including overload) does not exceed 500 W.

### 2.6. Input Power Application

The M2781-106 is designed to operate from the output of a PMG that is permanently connected to it and gradually rises from zero to the full rated AC voltage as the rotational speed of the PMG's is rising. The rate-of-change of the input voltage should not exceed 10 V<sub>rms</sub>/ms. Abrupt connection of the M2781-106 inputs to an operating DC source (as by a switch) may damage the M2781-106.

### 2.7. Enable Input

The Enable signal is a 28V discrete signal, referenced to the 28VDC\_RTN line. When High, the 28VDC Output is enabled and will provide power within 100mS, pending that the rectified Input voltage is higher than 39V<sub>DC</sub> for at least 500mS. When the Enable is Low the 28VDC Output is disabled. High is when the Enable signal is above 12V. Low is when it is Open (I<0.1mA, or V<6V). The load that the Enable input presents to the signal source can be estimated using the following equation:

$$I = (V-7) / 2.9K\Omega$$

When **I** is the loading on the Enable source in mA and **V** is the Enable voltage in volts. The absolute maximum voltage of the Enable signal is 33VDC (50V for up to 100mS).

### 2.8. BIT Output

The BIT output is an opto-isolated small-signal Open/Short type logic signal that indicates that all the internal modules of the M2781-106 are operating properly. The BIT signal is designed to interface with a 3K pull-up resistor (on the receiving side) to 5VCC. When no fault is detected the signal will be logic Low (<2Vdc), when a fault is detected, the signal will be High (>4Vdc).

### 2.9. Mean Time Between Failure (MTBF)

The MTBF of the M2781-106 (MIL-HDBK-217F GF) at 100VDC input, 2.8KW Load and 25 °C is higher than 50,000 hours.

### 2.10. Parallel Connection

Two units can be paralleled providing that both units are fed from a single AC source. To ensure proper operation in parallel:

Connect the AC input of the two units to the same AC source.

Connect all the +28VDC pins of the two units to a single point.

Connect all the 28VDC\_RTN pins of the two units to a single point.

Connect together the LS pins of the two units.

### 2.11. Electro Magnetic Compatibility (EMC)

The M2781-106 complies with CS114, CS115, CS116 of MIL-STD-461F and with RE102 and RS103 of MIL-STD-461F when the load and cables are properly shielded.

*The M2781-106 is not designed to meet CE101 or CE102. The M2781-106 and the PMG that feeds it are considered as a single EUT (Equipment Under Tests) and in accordance with MIL-STD-461F, these tests are applicable only to power lines "which obtain power from other sources not part of the EUT", hence not applicable to the M2781-106.*

### 2.12. Environmental Conditions

#### 2.12.1. Ambient Temperature

Non-operating: -55 °C to +80 °C

Operating: -40 °C to +72 °C. (See paragraph 3.2 for cooling requirements).

#### 2.12.2. Altitude

Up to 36,000 feet above MSL.

### 2.12.3. Acceleration

The M2781-106 will not be damaged and will provide full performance during and after exposure to 10 g load in any direction.

### 2.12.4. Mechanical Shock

The M2781-106 will not be damaged and provides full performances during and after exposure to 18 shocks (3 in each direction) of 20G/11ms. The M2781-106 will not be damaged by Maintenance Bench Drop per MIL-STD-810G.

### 2.12.5. Vibration

The M2781-106 will sustain without damage or deterioration and provides full performance during and after exposure to the operating vibration level specified in MIL-STD-810G, Method 514.7, Table 514.7C-VII and Table 514.7C-VIII.

### 2.12.6. Moisture

The M2781-106 is protected from humidity up to RH of 100%. It will not be damaged and will provide full performances when subjected to the 240 hours humidity test of MIL-STD-810G. The M2781-106 will not be damaged and provides full performance when exposed to dripping water at a rate of 280L/m<sup>2</sup> per hour in accordance with MIL-STD-810G, Method 506.6, Procedure III.

### 2.12.7. Fungus

The M2781-106 does not contain materials that support fungal growth.

### 3. PHYSICAL CHARACTERISTICS

#### 3.1. Weight and size

The M2781-106 outline dimensions are in accordance with drawing M2781006 (does not exceed 180 by 250 by 110 mm, excluding the I/O connectors). The M2781-106 weight does not exceed 4.9 kg.

#### 3.2. Cooling

The M2781-106 is a Baseplate cooled unit. It is the user responsibility to maintain the 180 by 250 mm Baseplate of the M2781-106 below 85 °C by thermally attaching it to a suitable heatsink using the 6 mounting threaded holes on the baseplate (see DWG M2781006). When the Baseplate temperature of the M2781-106 exceeds +75 °C, the rated output power is derated linearly by 130 W/°C, to 1.5 kW at 85 °C.

#### 3.3. I/O Connectors

##### 3.3.1. Input Connector: D38999/20WG11PN (Male, 11 pins AWG #12).

| Pin # | Description   | I/O |
|-------|---------------|-----|
| A     | AC IN Phase A | I   |
| B     | AC IN Phase A | I   |
| C     | AC IN Phase A | I   |
| D     | AC IN Phase B | I   |
| E     | AC IN Phase B | I   |
| F     | AC IN Phase B | I   |
| G     | AC IN Phase C | I   |
| H     | AC IN Phase C | I   |
| I     | AC IN Phase C | I   |
| J     | N/C           |     |
| K     | N/C           |     |

## M2781-106 - 28VDC/2.8KW AC to DC Power Supply

**3.3.2. Output connector: D38999/20WJ19SN (Female, 19 pins AWG #12\_**

| Pin # | Description | I/O |
|-------|-------------|-----|
| A     | Enable      | I   |
| B     | BIT         | O   |
| C     | 28VDC_RTN   | O   |
| D     | 28VDC_RTN   | O   |
| E     | 28VDC_RTN   | O   |
| F     | 28VDC_RTN   | O   |
| G     | +28VDC      | O   |
| H     | +28VDC      | O   |
| J     | +28VDC      | O   |
| K     | +28VDC      | O   |
| L     | +28VDC      | O   |
| M     | BIT_RTN     | O   |
| N     | LS          | I/O |
| P     | 28VDC_RTN   | O   |
| R     | 28VDC_RTN   | O   |
| S     | 28VDC_RTN   | O   |
| T     | +28VDC      | O   |
| U     | +28VDC      | O   |
| V     | 28VDC_RTN   | O   |

**M2781-106 - 28VDC/2.8KW AC to DC Power Supply**

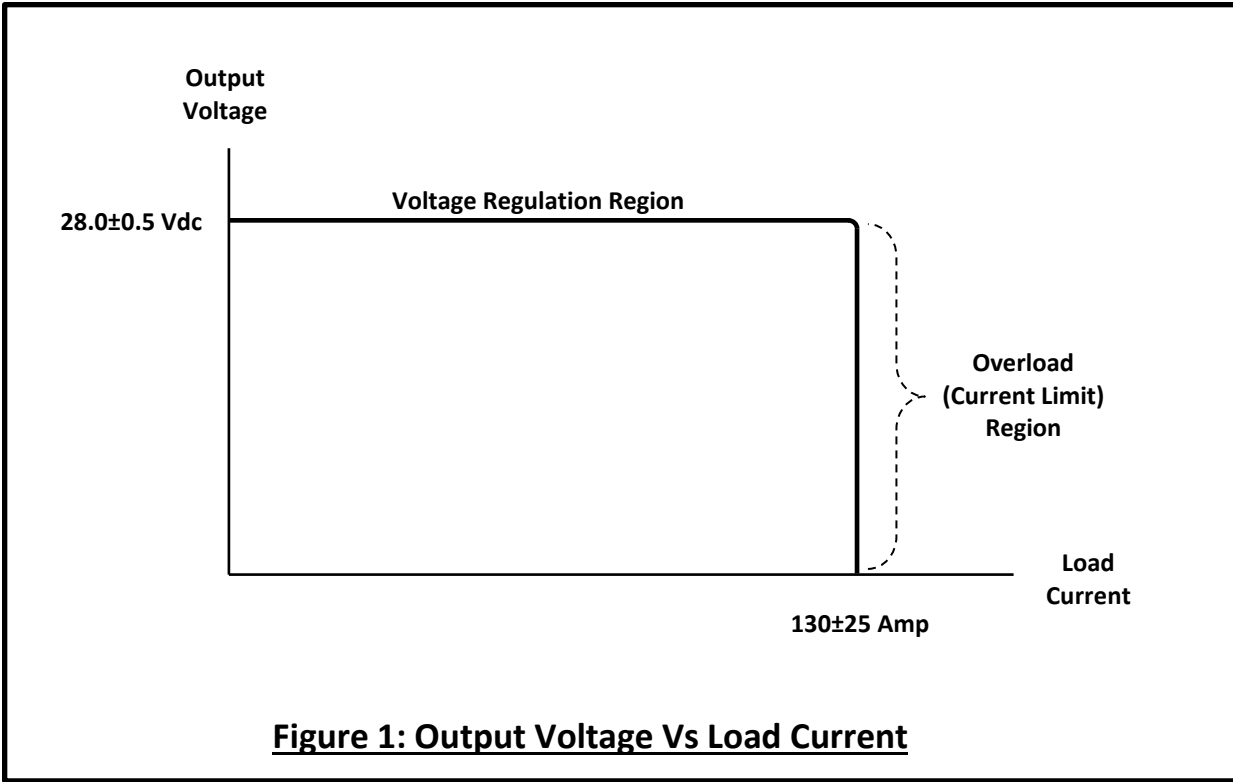

M2781-106 - 28VDC/2.8KW AC to DC Power Supply

OUTLINE DRAWING

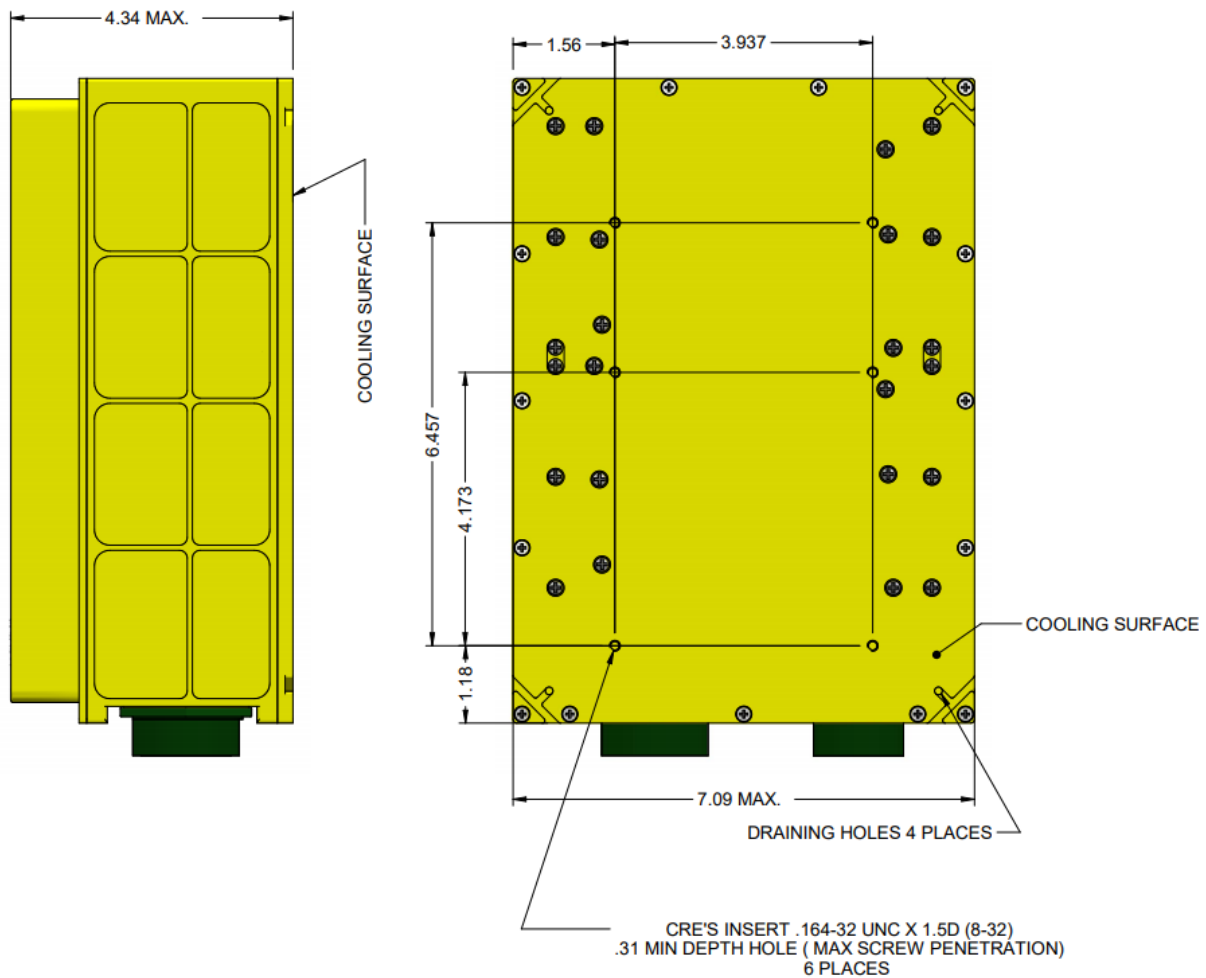

**M2781-106 - 28VDC/2.8KW AC to DC Power Supply**

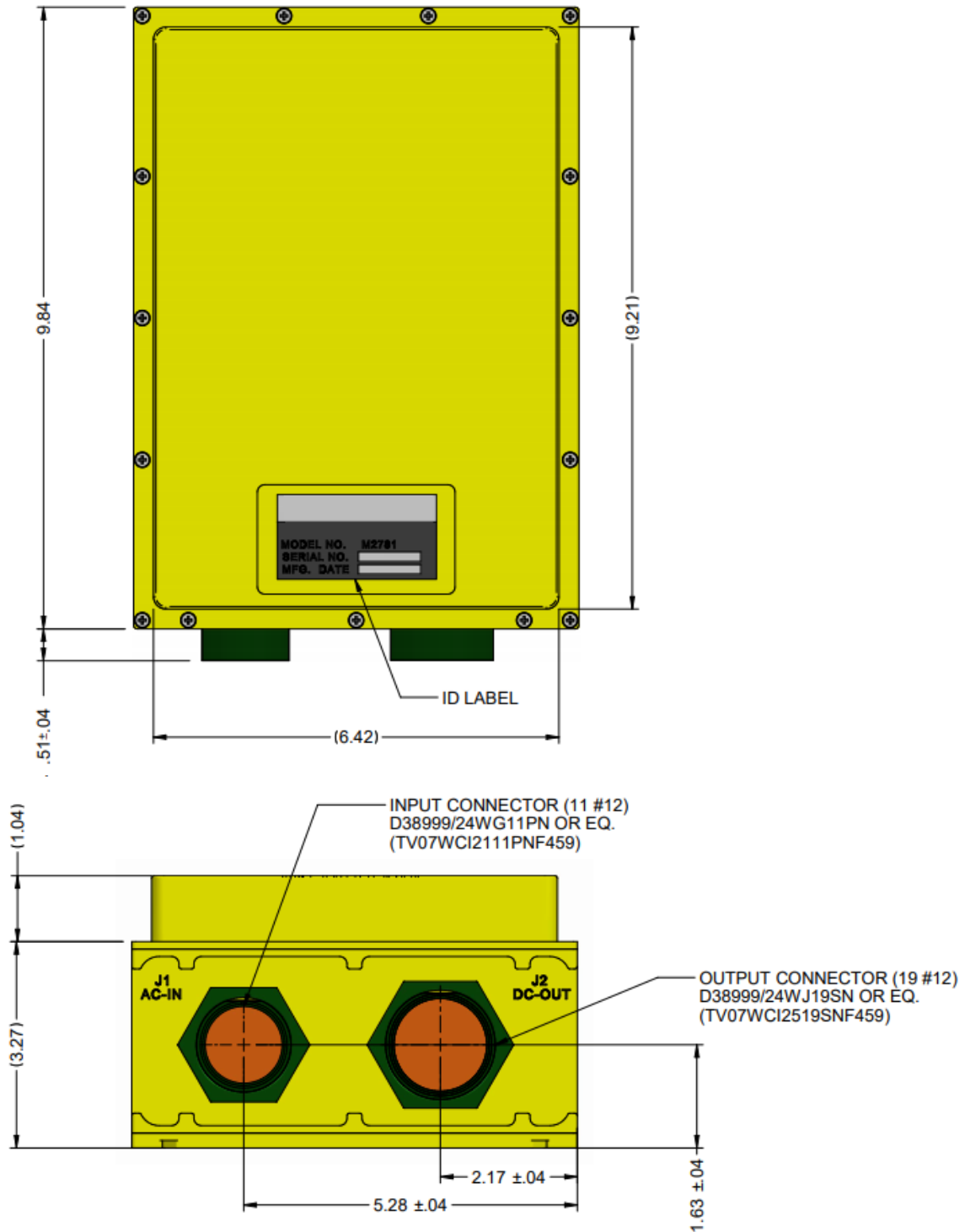

*Note: Specifications are subject to change without prior notice by the manufacturer*