

# M3169 SERIES

## SINGLE-OUTPUT, UP TO 1KW AC/DC POWER SUPPLY

The M3169 is a series of ruggedized, high-performance, base plate cooled, high performance, sealed enclosure 1kW single output AC to DC power supplies, for Navy shipboard, Airborne, and ground applications that are characterized by harsh and hostile environment.

The M3169 converts  $85 V_{AC} - 265 V_{AC} / 50-60Hz$  or  $90 V_{AC} - 180 V_{AC} / 400Hz$ , to a well-regulated, filtered and protected DC Output.



### THE MAIN FEATURES OF THE M3169 ARE:

- AC/DC Single output power supply up to 1kW
- 85V<sub>AC</sub>-265V<sub>AC</sub>/50-60Hz or 90V<sub>AC</sub>-180V<sub>AC</sub> / 400Hz Standard Input version, single-phase
- For extended input version - **Please contact factory for more details**
- High efficiency
- Wide input range
- High power factor
- Input / Output isolation
- Optional - Remote sense compensation - **Please contact factory for more details**
- EMI filters included
- Inrush Current Limiter
- TTL logic Inhibit
- Sustains high level of shocks and vibration, salt-fog, blowing rain, sand and dust.
- Sealed enclosure
- Non-latching protections:
  - Overload/Short-circuit
  - Output Overvoltage
  - Over Temperature
  - Input Undervoltage Lockout

## M3169 Series– AC/DC Power Supply

### Standard Models List (for other voltages – consult factory)

Part number	Input		Output		Special features	Type	
	Voltage range	Frequency	Voltage	Current		A	B
M3169-100	85V <sub>AC</sub> -265V <sub>AC</sub> / 1-phase	50/60/400Hz	5 V <sub>DC</sub>	36 A		V	
M3169-101	85V <sub>AC</sub> -265V <sub>AC</sub> / 1-phase	50/60/400Hz	12 V <sub>DC</sub>	36 A		V	
M3169-102	85V <sub>AC</sub> -265V <sub>AC</sub> / 1-phase	50/60/400Hz	24 V <sub>DC</sub>	36 A		V	
M3169-103	85V <sub>AC</sub> -265V <sub>AC</sub> / 1-phase	50/60/400Hz	28 V <sub>DC</sub>	36 A		V	
M3169-104	85V <sub>AC</sub> -265V <sub>AC</sub> / 1-phase	50/60/400Hz	48 V <sub>DC</sub>	21 A		V	
M3169-105	85V <sub>AC</sub> -265V <sub>AC</sub> / 1-phase	50/60/400Hz	270 V <sub>DC</sub>	4 A		V	
M3169-106	85V <sub>AC</sub> -265V <sub>AC</sub> / 1-phase	50/60/400Hz	28 V <sub>DC</sub>	36 A	Parallel operation via output voltage droop. Voltage regulation is ±2%	V	
M3169-110	85V <sub>AC</sub> -265V <sub>AC</sub> / 1-phase	50/60/400Hz	5 V <sub>DC</sub>	36 A			V
M3169-111	85V <sub>AC</sub> -265V <sub>AC</sub> / 1-phase	50/60/400Hz	12 V <sub>DC</sub>	36 A			V
M3169-112	85V <sub>AC</sub> -265V <sub>AC</sub> / 1-phase	50/60/400Hz	24 V <sub>DC</sub>	36 A			V
M3169-113	85V <sub>AC</sub> -265V <sub>AC</sub> / 1-phase	50/60/400Hz	28 V <sub>DC</sub>	36 A			V
M3169-114	85V <sub>AC</sub> -265V <sub>AC</sub> / 1-phase	50/60/400Hz	48 V <sub>DC</sub>	21 A			V
M3169-115	85V <sub>AC</sub> -265V <sub>AC</sub> / 1-phase	50/60/400Hz	270 V <sub>DC</sub>	4 A			V
M3169-116	85V <sub>AC</sub> -265V <sub>AC</sub> / 1-phase	50/60/400Hz	270 V <sub>DC</sub>	4 A	Parallel operation via output voltage droop. Voltage regulation is ±2%		V

- Additional standard configurations available. **Contact factory for more details.**
- All of our products can be configured to comply with EU REACH regulations. **Contact factory for more details.**

## M3169 Series– AC/DC Power Supply

### SPECIFICATIONS:

<b>AC Input</b>	<b>Voltage Range</b>	Option 1: 85 V <sub>AC</sub> -265 V <sub>AC</sub> /50 Hz - 60 Hz / Single-phase Option 2: 90 V <sub>AC</sub> -180 V <sub>AC</sub> /400 Hz / Single-phase For extended input version - <b>Please contact factory for more details</b>
	<b>Isolation</b>	1 000 V <sub>DC</sub> Input to Output 1 000 V <sub>DC</sub> Input and Case
	<b>Spikes</b>	<b>Optional</b> to withstand 1000 V spikes IAW MIL-STD-1399-300B. <b>please consult factory</b>
<b>DC Output</b>	<b>Voltage Regulation</b>	Up to ±2% (no load to full load, –40 °C to +85 °C and over normal input voltage range).
	<b>Optional Remote Sense</b>	The SENSE is used to achieve accurate load regulations at load terminals (this is done by connecting the pins directly to the load's terminals). For output voltage above 8V, the use of remote sense has a max limit of 0.25V voltage dropout between converter's output and load terminals. For output voltage below 8V, the use of remote sense has a max limit of 0.5V voltage dropout between converter's output and load terminals. When not used connect SENSE to OUT and SENSE RTN to OUT RTN.
	<b>Ripple and Noise</b>	(max. 1%) measured at load across 1 μF and 0.1 μF ceramic capacitors.
	<b>Isolation</b>	200 V <sub>DC</sub> Output and Case
	<b>Current Limit &amp; Overload</b>	Output turns off and on periodically (hiccup) until fault is condition removed. Protection threshold set at 120% ± 10% of maximum current
	<b>Efficiency</b>	Up to 83-87% - typical (nominal input voltage, full load, room temperature)
	<b>Overvoltage Protection</b>	<ul style="list-style-type: none"> <li>• <b>Active Over-Voltage Protection</b> Internal control shuts output down if voltage exceeds 110% ± 5% of nominal.</li> <li><b>Passive Over-Voltage Protection</b> A transorb, rated to 120% ± 10% of nominal voltage, is placed across the output.</li> </ul>
<b>Over Temp. Protection</b>	Unit shuts down if baseplate temperature exceeds 100 ± 5 °C. Automatic recovery upon cooldown to below 95 ± 5 °C.	

## M3169 Series– AC/DC Power Supply

### Specifications (Cont.):

<b>Environment Designed to meet MIL- STD-810F</b>	<b>Temperature</b>	Methods 501.4 & 502.4 Operating: –40 °C to +85 °C (at baseplate) Storage: –55 °C to +125 °C (ambient)
	<b>Humidity</b>	Method 507.6 test Procedure 2
	<b>Rain</b>	Method 506.6 Procedure 1,2
	<b>Sand &amp; Dust</b>	Method 510.6 Procedure 1
	<b>Salt-fog</b>	Method 509.6
	<b>Altitude</b>	Method 500.4 Procedures I – up to 70,000 ft. (non-operational) Procedure II – up to 40,000 ft. (operational)
	<b>Temperature Shock</b>	Method 503.6
	<b>Mechanical Shock</b>	Method 516.5 Procedure I 30 g, 11 ms terminal peak saw-tooth
	<b>Vibration</b>	Method 514.5 Procedure I Category 24 - General minimum integrity exposure
	<b>Temperature/ Altitude DE- RATING</b>	DE-RATE temperature linearly with altitude with a slope of - 9°C / 5000 FT TBR referenced to the maximum hot operating temperature at MSL
	<b>Fungus</b>	Method 508.7
<b>EMI</b>	<b>MIL-STD-461F</b>	MIL-STD-461F CE102, CS101, CS114, CS115, CS116, RE102, RS103
<b>Reliability</b>	150,000 hours, calculated per MIL-STD-217F Notice 2 at +85 °C baseplate, Ground Fixed environment.	
<b>Form factor</b>	7.25" wide, 3.1" high and 11" deep. For detailed dimensions and tolerances see Drawing: M2169001	
<b>Weight</b>	4 kg	
<b>Connectors</b>	See Page 9-10	

**TEST RESULTS**

**Plot 1.2: RE102 test results within 2 – 30 MHz, vertical polarization**

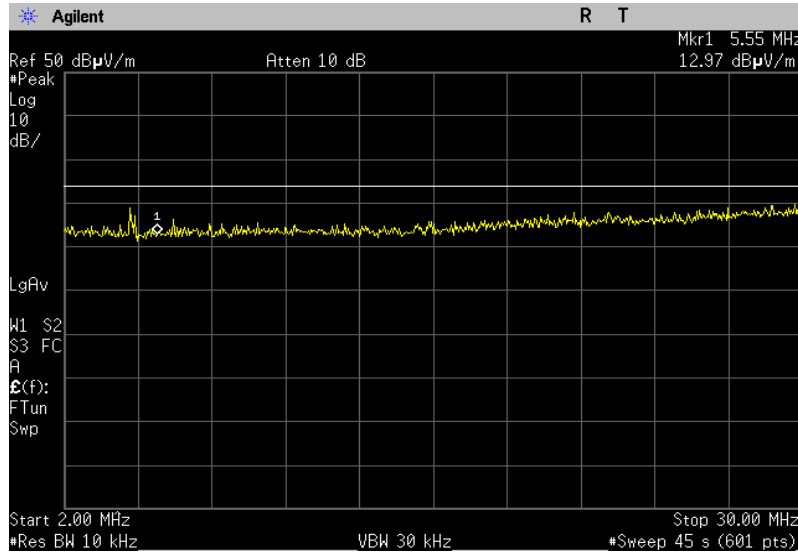

Display line is Limit

**Plot 1. 4: RE102 test results within 30 – 200 MHz, vertical polarization**

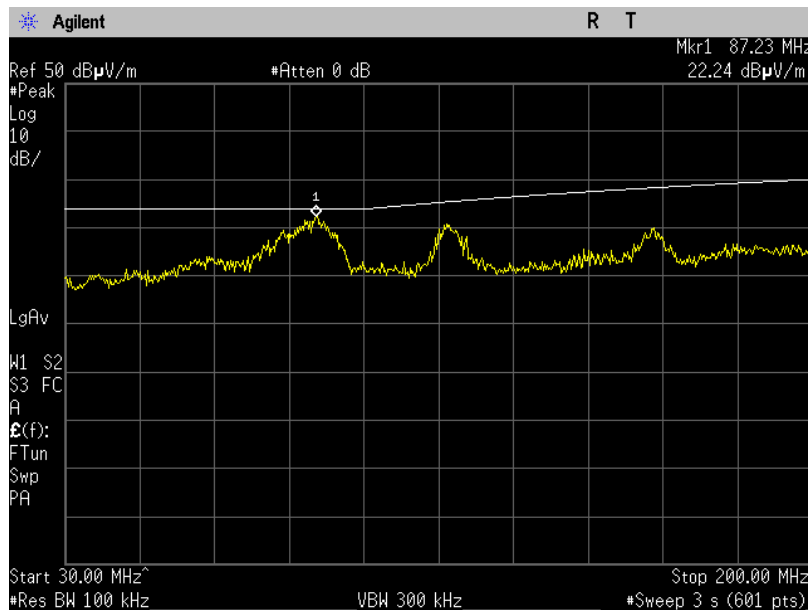

Display line is Limit

**M3169 Series– AC/DC Power Supply**

**Plot 1.6: RE102 test results within 30 – 200 MHz, horizontal polarization**

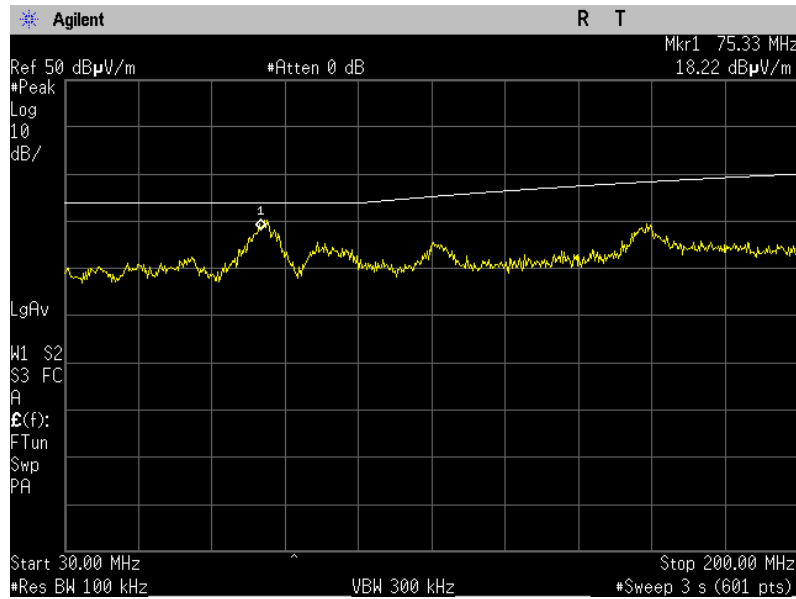

Display line is Limit

**Plot 1.8: RE102 test results within 200 – 1000 MHz, vertical polarization**

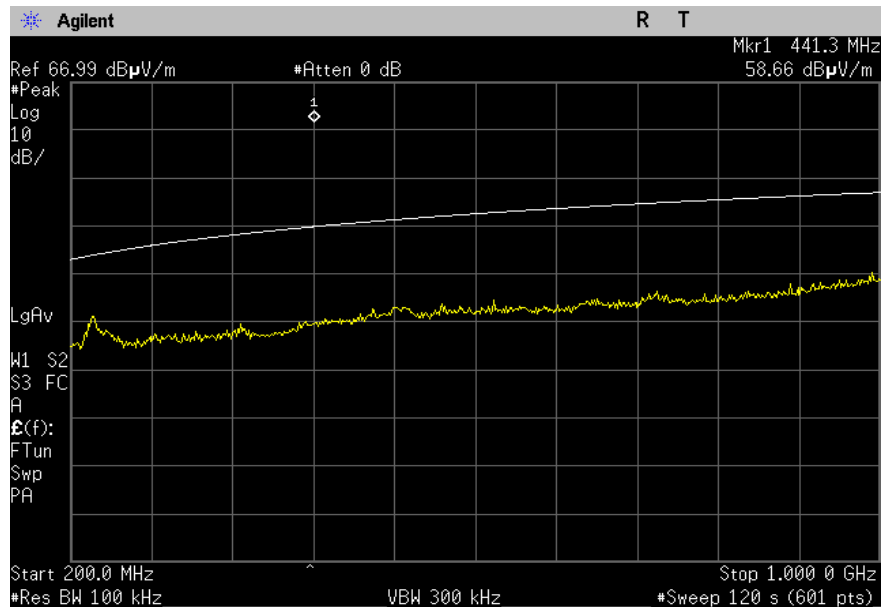

Display line is Limit

**M3169 Series– AC/DC Power Supply**

**Plot 1.10: RE102 test results within 200 – 1000 MHz, horizontal polarization**

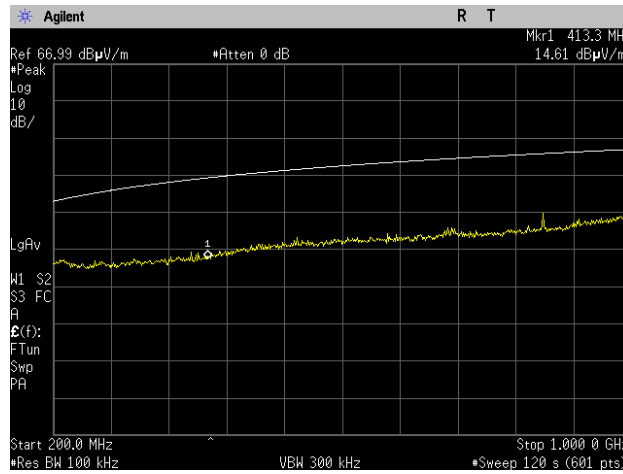

Display line is Limit

**TYPICAL TEST RESULTS - EFFICIENCY**

Efficiency Percent	Output Power	Output voltage	Input Power	Input voltage	Power Dissipation
74.4	150	28	201.6129	115	51.61290323
77.7	200	28	257.40026	115	57.4002574
78.6	450	28	572.51908	115	122.519084
82.6	750	28	907.99031	115	157.9903148

### PIN ASSIGNMENT: J1 - INPUT CONNECTOR

**Connector type:** D38999/24WC4PN (4#16 PINS)

Pin #	Function
A	PHASE
B	NEUTRAL
C	CHASSIS GND
D	(SPARE) NOT CONNECT

### CHASSIS Note: Chassis PIN

This pin is connected to the converter's chassis.

## M3169 Series– AC/DC Power Supply

### **PIN ASSIGNMENT: J2 - OUTPUT CONNECTOR - OPTION A**

**Connector type:** D38999/24WE6SN (6#12 SOCKETS) or eq.

Pin #	Function
A	VOUT
B	VOUT RTN
C	CHASSIS GND
D	VOUT
E	VOUT RTN
F	CHASSIS GND

**Note:** All pins with identical function/designation should be connected together for optimal performance.

#### **CHASSIS Note: Chassis PIN**

This pin is connected to the converter's chassis.

### **PIN ASSIGNMENT: J2 - OUTPUT CONNECTOR- OPTION B**

**Connector type:** D38999/24WE6SN (6#12 SOCKETS) or eq.

Pin #	Function
A	VOUT
B	VOUT RTN
C	SENSE
D	VOUT
E	VOUT RTN
F	SENSE RTN

**Note:** All pins with identical function/designation should be connected together for optimal performance.

#### **CHASSIS Note: Chassis PIN**

This pin is connected to the converter's chassis.

## M3169 Series– AC/DC Power Supply

### PIN ASSIGNMENT: J2 - OUTPUT CONNECTOR - OPTION C

**Connector type:** D38999/24WE6SN (6#12 SOCKETS) or eq.

Pin #	Function
A	VOUT
B	VOUT RTN
C	INHIBIT
D	VOUT
E	VOUT RTN
F	INHIBIT RTN

**Note:** All pins with identical function/designation should be connected together for optimal performance.

#### **INHIBIT Note:**

The “INHIBIT” signal is used to turn the power supply ON and OFF.

- TTL “0” or SHORT – will turn on the power supply.
- TTL “1” or OPEN– will turn off the power supply.

The ground reference for the “INHIBIT” signal is “INHIBIT RTN”.

### PIN ASSIGNMENT: J2 - OUTPUT CONNECTOR - OPTION D

**Connector type:** D38999/24WE6SN (6#12 SOCKETS) or eq.

Pin #	Function
A	VOUT
B	VOUT RTN
C	VOUT RTN
D	VOUT
E	VOUT RTN
F	VOUT

**Note:** All pins with identical function/designation should be connected together for optimal performance.

### BLOCK DIAGRAM – OPTION A

M3169 Series– AC/DC Power Supply



**BLOCK DIAGRAM – OPTION B**



**BLOCK DIAGRAM – OPTION C**

## M3169 Series– AC/DC Power Supply

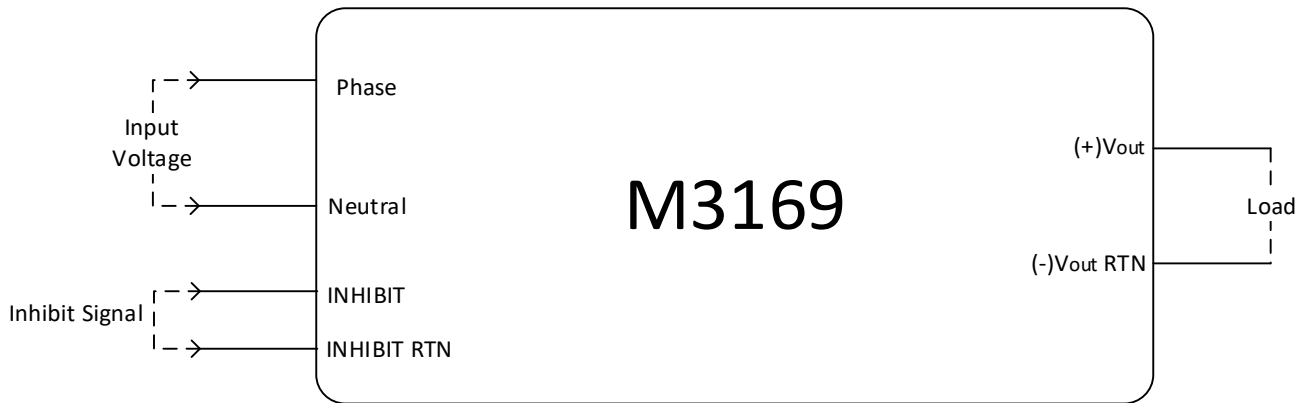

### BLOCK DIAGRAM – OPTION D



# M3169 Series– AC/DC Power Supply

## OUTLINE DRAWING:

For detailed dimensions and tolerances see Drawing: M3169001

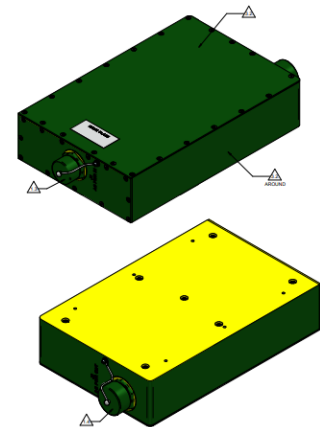
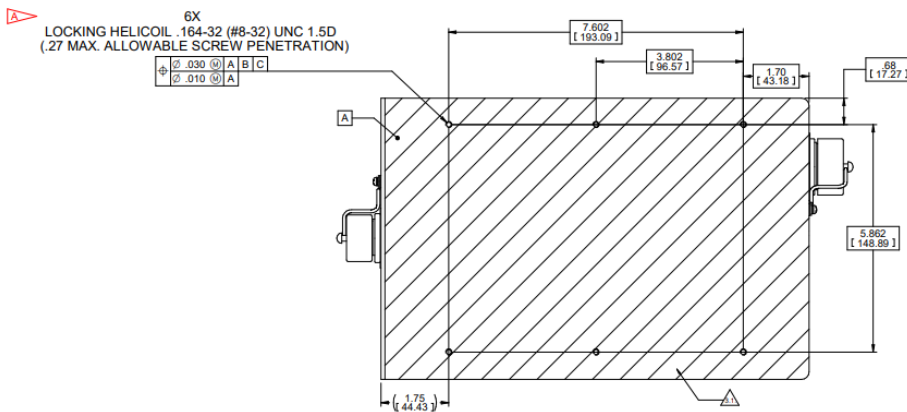
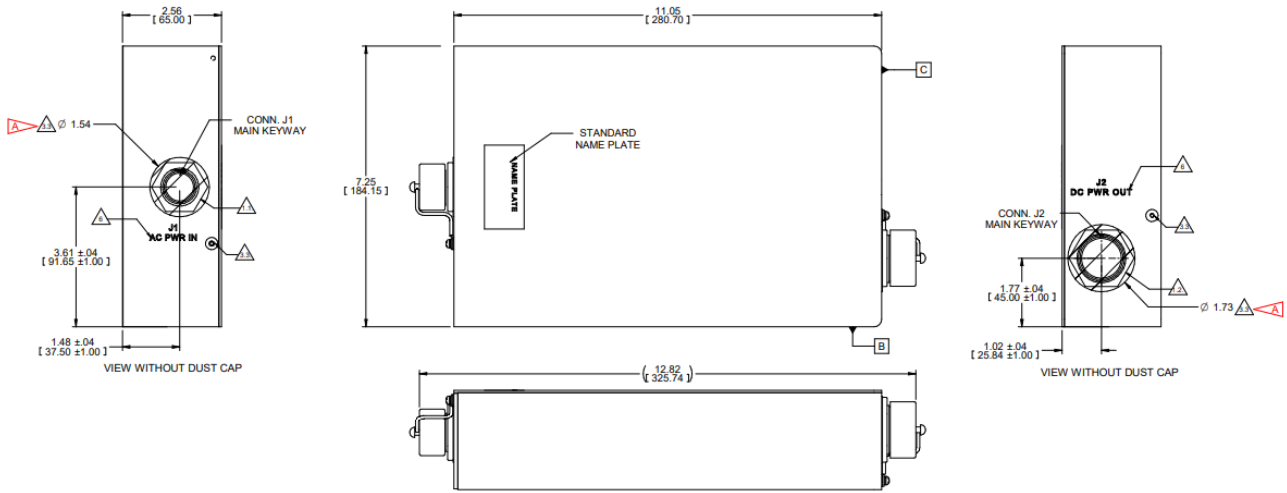

### NOTES:

1. CONNECTORS:
  - 1.1. J1- CONN. AC PWR IN, P/N D38999/24WC4PN OR EQ.
  - 1.2. J2- CONN. DC PWR OUT, P/N D38999/24WE6SN OR EQ.
  - 1.3. CONN. J1 DUST CAP, P/N D38999/33W13R OR EQ.
  - 1.4. CONN. J2 DUST CAP, P/N D38999/33W17R OR EQ.
2. MATERIAL: AL 6061-T651, AL 5052-H32, OR EQ.
3. COATINGS AND PAINT:
  - 3.1. INTERNAL AND UNPAINTED SURFACES: CHROMATE CONVERSION COATING PER MIL-DTL-5541 TYPE II CLASS 3 CLEAR.
  - 3.2. EXTERNAL SURFACES: PRIMER: PER MIL-PRF 23377K OR EPOXY PER MIL-DTL-53022E. THICKNESS: 15-25 MICRON. TOP COAT: FED-STD-595 34094 GREEN 383 CAMO. THICKNESS: 45-60 MICRON.
  - 3.3. PREVENT PAINT FROM CROSSHATCHED AREAS, CONNECTORS, THREADS, DUST CAPS, SCREWS AND HARDWARE.
4. WORKMANSHIP SHALL BE MIL-STD-454, REQ. 9.
5. MAX WEIGHT: 10.35 LBS.
6. ENGRAVING:
  - 6.1. CHARACTER HEIGHT: .15 IN.
  - 6.2. CHARACTER DEPTH: .02 IN.
  - 6.3. FONT: ARIAL.
  - 6.4. CHARACTER ARE CENTRALLY LOCATED.
  - 6.5. FILL ENGRAVING WITH BLACK LUSTERLESS EPOXY PAINT. COLOR PER FED-STD 595 NO. 37038.

UNLESS OTHERWISE SPECIFIED DIMENSIONS ARE IN (IN). DO NOT SCALE DRAWING	GENERAL TOLERANCES
	.XX ± .03 .XXX ± .020 ANGLES ± 1.0°

**Please note: Specifications are subject to change without prior notice by the manufacturer.**