

M4090 SERIES

1 200 W DC/DC 6U VITA 62 POWER SUPPLY

The M4079 is a series of 6U VITA 62 compliant mechanically robust, conducted cooled by wedge locks, high performance, 1.2kW DC to DC six outputs power supplies, designed for Ground Mobile (MIL-STD-1275), Airborne (MIL-STD-704) and other Hi-Reliability applications where 270VDC has to be converted to a tightly regulated, filtered and protected DC outputs.



THE MAIN FEATURES OF THE M8139 ARE:

- Vita 62 compliant
- 6U VPX form factor
- Six outputs
- 270V DC/DC converter
- Up to 1200W
- VITA 62/6U
- Over temperature shutdown with auto-recovery
- EMI filters included
- Fixed switching frequency
- Indefinite short circuit
- High efficiency
- Input / Output isolation
- Remote sense
- I2C/IPMI communication
- protection with auto-recovery
- Over-voltage shutdown with auto-recovery
- Parallel configuration
- External Inhibit & Enable

M4090 Series– DC/DC Power Supply

SPECIFICATIONS:

DC Input	Voltage Range	270VDC Ride-through normal transient IAW MIL-STD-704E/F For extended input version - Please contact factory for more details		
	Isolation	500V _{DC} Input to Output 500V _{DC} Input to Case		
	Inrush Current Limit	peak value of 5 x I _{IN} for inrush currents lasting longer than 100µs.		
DC Output	Rating	P01*	12V/35A	Sense
		P02*	12V/35A	Sense
		P03	5V/12V/40A	Sense
		3.3V_Aux	3.3V/15A	Sense
		+12V_Aux	+12V/1A	
		-12V_Aux	-12V/1A	
		Total power output: 1200W		
	Voltage Regulation	Better than or equal to ±1% (no load to full load, low line to high line, -55 °C to +85 °C).		
	Sense	See page 7		
	Ripple	Less than 50 mVp-p, typical (max. 1%) measured across 0.1µF and 10µF on Load		
Isolation	500V _{DC} Output to Case			
Current Limit & Overload	Overload / Short Circuit Protection Continuous protection (10-30% above maximum current) for unlimited			
Efficiency	Typical 89% (Nominal line, nominal load, room temperature)			
Overvoltage Protection	Set to engage at 110%-130% of nominal voltage.			
Over Temp. Protection	Shutdown at temperature of +100°C ± 5°C. Automatic recovery when temperature drops below +90°C ± 5°C. Measured at Unit edge.			

M4090 Series– DC/DC Power Supply

SPECIFICATIONS (CONT.):

Control & Indication	<i>INHIBIT Input</i>	See page 5
	<i>SIGNAL RTN</i>	See page 5
Environment Designed to meet MIL-STD-810G	<i>Temperature</i>	Operating: –55°C to +85°C (at plug-in card edge, IAW VITA 62 CC4) Storage: –55°C to +125°C
	<i>Humidity</i>	Method 507.5 & VITA 47 Para. 4.6 Up to RH 95%
	<i>Salt-fog</i>	Method 509.4
	<i>Altitude</i>	Method 500.5, Procedure II (Operational) & VITA 47 para. 4.7 60,000 ft.
	<i>Mechanical Shock</i>	Method 516.6 Procedure I & VITA 47 Shock Class OS1 Saw-tooth, 20g peak, 11ms.
	<i>Vibration</i>	Method 514.6 Procedure I Figure 514.5C-17. General minimum integrity exposure. (1 hour per axis & VITA 47 Vibration Class V2 5-2000Hz, 0.04g ² /Hz
	<i>Fungus</i>	Does not support fungus growth, in accordance with the guidelines of MIL-STD-454, Requirement 4
EMI	<i>MIL-STD-461F</i>	Designed to meet MIL-STD-461F CE102, CS101, CS114, CS115 & CS116.
Reliability	> 100,000 hours, calculated per MIL-STD-217F Notice 2 at +85°C at wedge lock edge, Ground Fixed	
Cooling Requirements	Unit is a conducted cooled by wedge locks, Max temperature of +85 °C is allowed at units edge per VITA62/	
Form factor	9.187" wide, 0.97" high and 6.63" deep.	
Weight	Approx. 4 lbs	
Connectors	See pages 12-13	

M4090 Series– DC/DC Power Supply

FUNCTIONS AND SIGNALS (ACCORDING TO VITA 62.0)

Signal No.	Signal Name	Type	Description	
1	FAIL*	Output	Indicates to other modules in the system that a failure has occurred in one of the outputs. This signal is normally High, goes low during fail.	
2	INHIBIT*	Input	Controls power supply outputs. Connecting this signal to SIG_RTN turns the output power OFF.	
3	ENABLE*	Input	Controls the input power to the power supply. This signal in conjunction with INHIBIT* turns the output power ON and OFF. Please refer to Table 1 for combination of INHIBIT* & ENABLE* .	
4	SYSRESET*	Input	Indicates to other modules in the system that all outputs are within their working level. This signal is normally High, goes low during fail.	
5	PO#_SHARE	Bidirectional	Enables current share between two paralleled outputs of two devices. For more details see Para. 3.	
6	PO#_ACS	Bidirectional	Enables Active current share between two paralleled outputs of two devices. For more details see Para. 3.	
7	PO#_SENSE PO#_SENSE_RTN	Input	Used to correct output voltage at regulation point, when voltage droop occurs due to current flowing through output wires. This feature is limited up to approximately 0.5V above nominal voltage.	
8	GA4* ... GA0* & GAP*	Input	Used for geographical addressing. GA4* is the most significant bit and GA0* is the least significant bit. GAP* indicates the parity.	
9	SCL	Bidirectional	I2C bus Clock	Through this bus the power supply module's temperature can be shared.
10	SDA	Bidirectional	I2C bus Data	
11	UD#	N/A	User defined signals. Contact factory for further information.	

NOTE: All Signals with an asterisk (*) suffix represent signals which are "active low".
All signals refer to **SIG_RTN**

Table 1 – Inhibit and Enable Functionality

INHIBIT*	Low	Low	High	High
ENABLE*	Low	High	Low	High
VS1, VS2, VS3, ±12VAux	OFF	OFF	ON	OFF
3.3V_AUX	ON	OFF	ON	OFF

Figure 1 – Inhibit and Enable Input stage

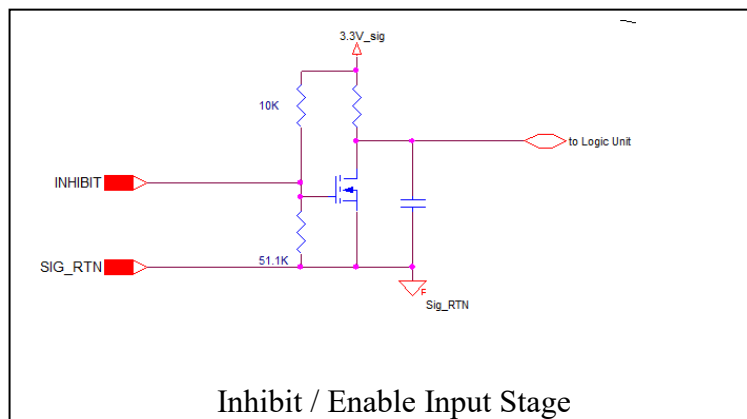
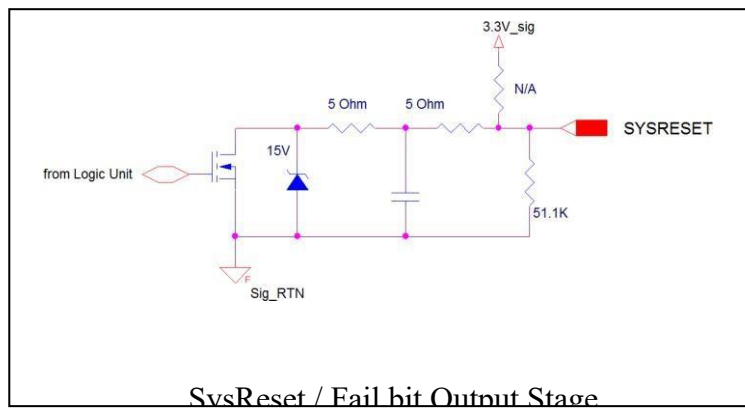

Figure 2 – SysReset and Fail Bit Output Stage



NOTE: All Signals with an asterisk (*) suffix represent signals which are "active low".

DETAILED INFORMATION

1. Input Voltage Operation.

The M4090 steady state operation is per Mil-STD-704 Unit will work thorough all Normal Transients.

Unit is protected during Abnormal transients and interrupts.

2. Outputs Voltage Regulation

The M4090 contains accurate internal sense lines to keep output voltage at less than 3% regulation for all Line / Load and temperature range (see Table 2).

Output	12V/25A	5V/30A	3.3V/20A	3.3VAux/5A	12VAux/1A	(-)12VAux/1A
Voltage Range	11.85 – 12.15	4.9 – 5.1	3.28 – 3.42	3.2 – 3.4	11.65 – 12.15	(-)11.85 – (-)12.15

Table 2: Outputs voltage regulation. Temperature -55°C – 85°C

2.1 Sense Lines

Sense Lines are provided for VS1, VS2 and VS3 output to compensate line voltage drop. *Sense Lines* proper connection is shown in Figure 3.

Each VS# output has its own *Sense Lines*, additional common *Sense RTN*

Line is provided for all VSx Outputs (VITA 62 Standard).

Contact Factory for Sense configuration different than the VITA 62 standard

Note: when two or three VS# have the same configuration (e.g. VS1 and VS2 are both 12V), sense lines of those outputs will be shorted internally.

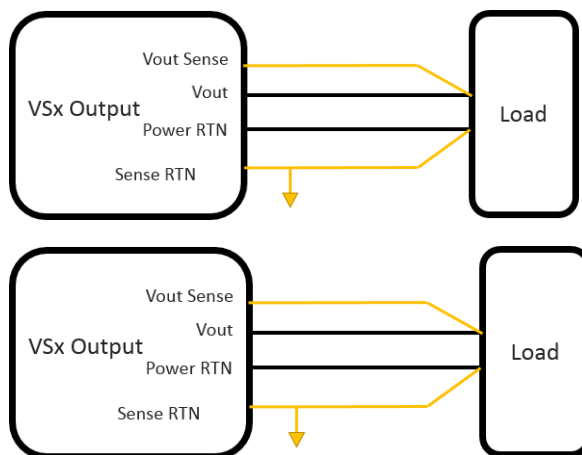

Figure 3: M4090 Sense line connection

3.0 Current Share (C.S)

Two VS# outputs can be configured as current share to double the output current.

It is also possible to support parallel configuration of two units. VS1, VS2 and VS3 will current share with about 5-10% load balance.

All Aux Outputs can be paralleled, but would not support current sharing.

The unit can support two methods of current sharing:

3.1 Passive Current Sharing (P.C.S)

Current sharing is done in open loop, output voltage drops as a function of output load.

3.2 Active current sharing (A.C.S)

Current sharing is done in a closed loop. All paralleled outputs are compared and feedback is used to balance their load current. The result is a more stable, less sensitive output voltage without voltage drop.

3.3 Current share connection between two Units.

3.3.1 Passive Current Share:

For a required output to P.C.S please connect the following Pins between the two units

- *PO#_Sense & PO#_Sense_RTN*
- *PO#_SHARE*

Note: if two outputs of a unit are configured as paralleled, the Pins above are internally shorted.

3.3.2 Active Current Share:

For a required output to A.C.S please connect the following Pins between the two units

- *PO#_Sense & PO#_Sense_RTN*
- *PO#_SHARE*
- *PO#_ACS*

Note: if two outputs of a unit are configured as paralleled, the Pins above are internally shorted

4. IPMI Protocol¹

Electrical Parameters

Vcc: 3.3VDC

Pull-up: 2.2kOhm Input capacitance: 100pf

Slave Device Addressing

- 256 address spaces
- Baud rate: 200kHz maximum
- 7 Bit Protocol
- Support Slot Addressing per VITA 62
- Support Global Address 10100101 R/W

M4090 Series– DC/DC Power Supply

Slot Number	MSB							LSB
	A6	A5/*GAP	A4/*GA41	A3/*GA3	A2/*GA2	A1/*GA1	A0/*GA0	R/W
Slot0	1	0	0	0	0	0	0	
Slot1	1	0	0	0	0	0	1	
Slot2	1	0	0	0	0	1	0	
Slot3	1	0	0	0	0	1	1	
General Call	1	0	1	0	1	0	1	

* Slot location is determined by GAx per VITA 62.

Communication Supported

Read Command – 21Hex, deliver 64Bytes of Data. (More commands are available by request)
 The communication starts when the master sends a start followed by the unit slave address, command, checksum and a stop. A second start followed by the slave address and a read will be followed by a 64 Bytes response.

S	Slave Address	R/W	A	Command	A	Check sum	A	P
	A6:A0	0	0	21 Hex	0	DF Hex	0	

S	Slave Address	R/W	A	DATA	A	DATA	A	DATA	A	...	DATA	A	Check sum	N/A	P
	A6:A0	1	0	D7:D0	0	D7:D0	0	D7:D0	0		D7:D0	0	D7:D0	1	

Command – 21Hex read all 64 Bytes

S - Start

P- Stop

Master Transmit	Unit Transmit

Note 1 – for 46.11 Protocol, please contact factory

M4090 Series– DC/DC Power Supply

MEMORY SPACE

Response Byte #	Data Type	Meaning	Interpretation	Reading Range
0	U Integer, MSB First	Echo of Command		21 Hex
1	U Integer, MSB First	N/A		00 Hex
2	S Integer, MSB First	Temperature	T(C°)=+/- 7bit Dec	-55 C° to 125 C°
3	U Integer, MSB First	Reserved	00Hex	
4-5	U Integer, MSB First	VS1 Voltage	V(out) = Data/ m2	20.48V
6-7	U Integer, MSB First	VS2 Voltage	V(out) = Data/ m2	20.48V
8-9	U Integer, MSB First	VS2 Voltage	V(out) = Data/ m2	20.48V
10-11	U Integer, MSB First	3.3V Aux Voltage	V(out) = Data/ m2	20.48V
12-13	U Integer, MSB First	12V Aux Voltage	V(out) = Data/ m2	20.48V
14-15	U Integer, MSB First	(-)12V Aux Voltage	V(out) = Data/ m2	20.48V
16-17	U Integer, MSB First	12V VS1 Current	V(out) = Data/ m3	40A
18-19	U Integer, MSB First	3.3V VS2 Current	V(out) = Data/ m3	40A
20-21	U Integer, MSB First	5V VS2 Current	V(out) = Data/ m3	40A
22-23	U Integer, MSB First	3.3V Aux Current	V(out) = Data/ m5	20A
24-35	U Integer, MSB First	12V Aux Current	V(out) = Data/ m4	10A
26-27	U Integer, MSB First	(-)12V Aux Current	V(out) = Data/ m4	10A
28-29	U Integer, MSB First	Reserved	00Hex	
30-31	U Integer, MSB First	Reserved	00Hex	
32-51	Character String (ASCII)	Part Number	M4090-1 (Note1)	20 Characters
52-53	Decimal, MSB First	Serial Number, 2MSB Dig	X,X Dec TBD (Note2)	N/A
54-55	Decimal, MSB First	Serial Number, 2LSB Dig	X,X Dec (Note2)	N/A
56-57	Decimal, MSB First	Date Code	Week, Year (Note3)	N/A
58-59	Character String (ASCII)	Hardware Rev	B01 & B02 Boards (Note4)	2 Characters
60-61	Decimal, MSB First	Firmware Rev	X,X,X,X Dec (Note5)	4 digits
62	U Integer, MSB First	Reserved		AA Hex
63	U Integer, MSB First	Zero Checksum	Value required to make the sum of bytes 0 to 62 added to a multiple of 256	

Note:

$$M_2 = 20.48 / 2^{16-1}$$

$$M_3 = 40 / 2^{16-1}$$

$$M_4 = 10 / 2^{16-1}$$

$$M_5 = 20 / 2^{16-1}$$

M4090 Series– DC/DC Power Supply

Notes 1 to 5:

1. Part Number Example: M4065-4

Byte No'	32	33	34	35	36	37	38	39-51
Character	M	4	0	6	5	(-)	4	0
Hex	4D	34	30	36	35	2D	34	00

2. Serial Number Example: 25

Byte No'	52		53		54		55	
Dec Number	0	0	0	0	0	0	2	5
Binary	"0000"	"0000"	"0000"	"0000"	"0000"	"0000"	"0010"	"0101"

3. Date Code Example: week 35 of 2018

Byte No'	56		57	
Dec Number	3	5	1	8
Binary	"0011"	"0101"	"0001"	"1000"

4. Hardware Rev Example: B01 Rev (-), B01 Rev A

Byte No'	58	59
Character	(-)	A
Hex	2D	41

5. Firmware Rev Example: 2.1.0.0

Byte No'	60		61	
Dec Number	2	1	0	0
Binary	"0010"	"0001"	"0000"	"0000"

M4090 Series– DC/DC Power Supply

PIN ASSIGNMENT

Connector P0

Connector type: 6450843-6 or eq.

Pin Number	Signal Name
P7	+DC_IN
P6	+DC_IN
P5	-DC_IN
P4	-DC_IN
P3	
P2	
P1	CHASSIS_GND

M4090 Series– DC/DC Power Supply

Connector P1:

Connector type: 6450849-6or eq.

<i>Pin Number</i>	<i>Pin Name</i>
P10	12V/35A PO1
P9	12V35A PO2
A9	PO1_SENSE
B9	PO2_SENSE
C9	PO3_SENSE
D9	(-)CLK
A8	PO1_SENSE_RTN
B8	PO2_SENSE_RTN
C8	PO3_SENSE_RTN
D8	+CLK
A7	PO1_SHARE
B7	PO2_SHARE
C7	PO3_SHARE
D7	SIGNAL_RETURN
P8	POWER_RETURN
P7	POWER_RETURN
A6	+CLK
B6	-CLK
C6	-12V_AUX
D6	SYSRESET*
A5	GAP*
B5	GA4*
C5	SCL
D5	SDA

<i>Pin Number</i>	<i>Pin Name</i>
A4	GA3*
B4	GA2*
C4	GA1*
D4	GA0*
A3	VS1 ACS
B3	+12V_AUX
C3	N.C
D3	N.C
P6	5V/40A PO3
P5	5V/40A PO3
P4	POWER_RETURN
P3	POWER_RETURN
A2	N.C
B2	FAIL*
C2	INHIBIT*
D2	ENABLE*
A1	3.3Vaux Sense
B1	3.3Vaux Sense return
C1	VS3 ACS
D1	VS2 ACS
P2	3.3V/15A
P1	POWER_RETURN

M4090 Series– DC/DC Power Supply

OUTLINE DRAWING

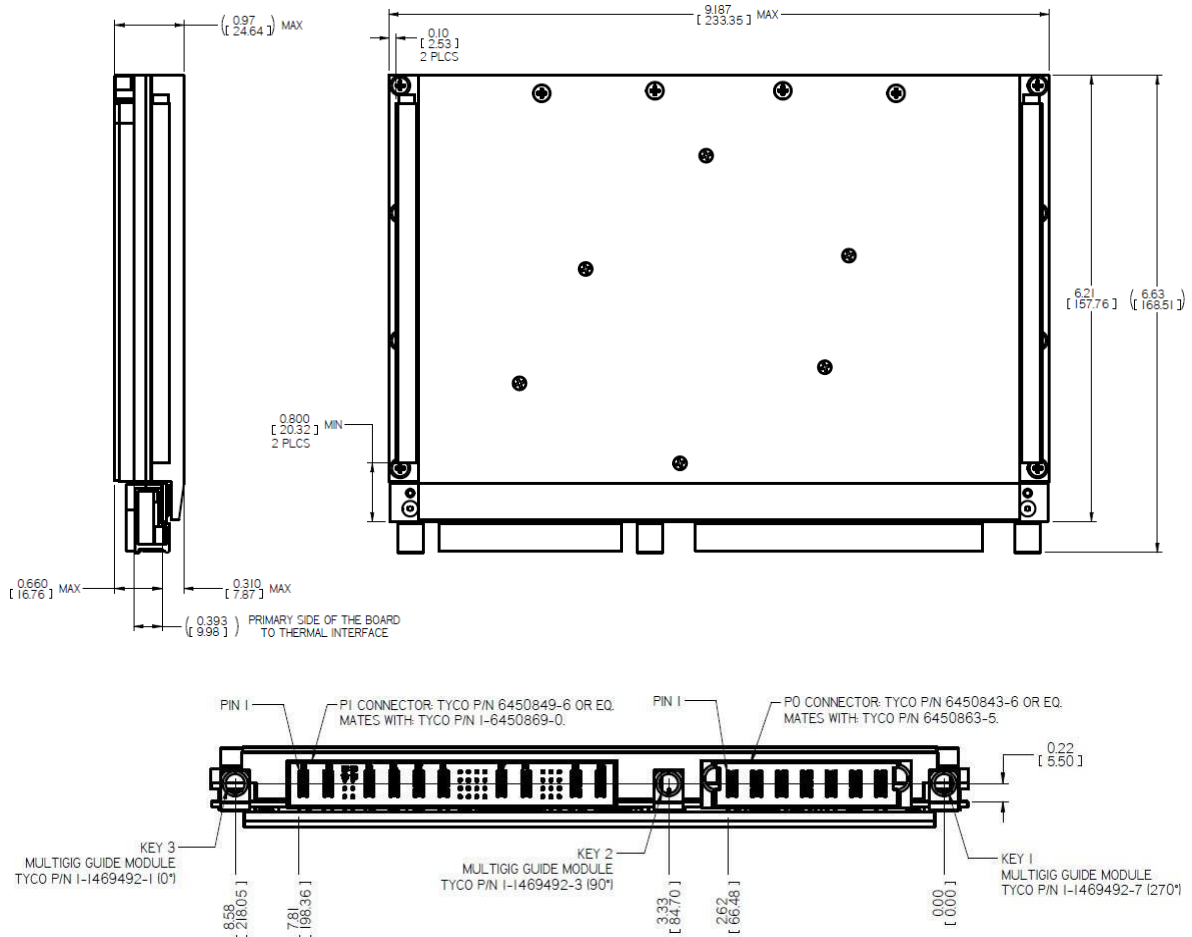

Notes

- Dimensions are in Inches [mm]
- Tolerance is:
 .XX ± 0.01 IN
 .XXX ± 0.005 IN
- Weight: Approx. 4 lbs

*** Specifications are subject to change without prior notice by the manufacturer.**