

# M4440 SERIES

## Power Supply Data Sheet

3U VPX 28V 370W  
VITA 47.1 CC4/CCW6 NT4 V3 OS2 C4 AV2 SF1/SF3 CS5

### *Product Highlight*

- *Vita62 form factor*
- *48V Output*
- *EMI Mil-STD-801G*
- *Operational Temperature  
-55°C to +85°C (unit Edge)*  
*Input Options:*
  - *Mil-STD-704*
  - *Mil-STD-1275 Transients*

## Table of Contents

ERROR! BOOKMARK NOT DEFINED.

<b>1. Scope</b>	<b>3</b>
<b>2. Module High Level Specification</b>	<b>3</b>
<b>2.1 Special Features</b>	<b>3</b>
<b>3. M4440 Power Supply Operation</b>	<b>4</b>
<b>3.1 Unit Block Diagram</b>	<b>4</b>
<b>3.2 Electrical Specification</b>	<b>5</b>
<b>3.2.1 Protection</b>	<b>5</b>
<b>3.3 Environmental Specification</b>	<b>6</b>
<b>3.4 Unit Interfaces</b>	<b>7</b>
<b>3.4.1 Connectors</b>	<b>7</b>
<b>3.4.2 Functions and Signals</b>	<b>8</b>
<b>3.5 Power Detailed Description</b>	<b>9</b>
<b>3.5.1 Input Voltage</b>	<b>9</b>
3.5.1.1 Operational Input Range	<b>9</b>
3.5.1.2 Transient Response	<b>9</b>
3.5.1.3 Voltage Distortion	<b>11</b>
3.5.1.4 Input Redundancy	<b>11</b>
3.5.1.5 Input Voltage Rise Time	<b>11</b>
3.5.1.6 Inrush Currents	<b>11</b>
<b>3.5.2 Outputs</b>	<b>12</b>
3.5.2.1 Outputs Controls: Enable & Inhibit Signals	<b>11</b>
3.5.2.2 Output Power	<b>11</b>
3.5.2.3 Voltage regulation and Ripple	<b>11</b>
3.5.2.4 Turn-on & Sequencing	<b>12</b>
3.5.2.5 Sense Connection	<b>12</b>
3.5.2.6 Dynamic Response	<b>13</b>
3.5.2.7 Current Share	<b>13</b>
3.5.2.8 Short Protection	<b>13</b>
3.5.2.9 Holdup	<b>13</b>

## M4440 VPX Power Supply

<b>3.5.3</b>	<b>Signals</b>		<b>14</b>
3.5.3.1	Fail bit & SYSTEM RESET	<b>15</b>	
3.5.3.2	SYNC IN	<b>15</b>	
<b>3.5.4</b>	<b>Built In Tests</b>		<b>15</b>
<b>3.5.5</b>	<b>Thermal Management</b>		<b>16</b>
<b>3.6</b>	<b>System Management</b>		<b>17</b>
3.6.1	Electrical Interface	<b>17</b>	
3.6.2	Communication Protocol		<b>17</b>
3.6.2.1	Advanced I2C Protocol		<b>18</b>
<b>3.7</b>	<b>Pinout</b>		<b>19</b>
<b>3.8</b>	<b>Mechanical SCD</b>		<b>20</b>

## M4440 VPX Power Supply

### 1. Scope

The M4440 Power supply is a member of Milpower VPX product line and is intended to serve at 28V Input DC line to support a total of 370W steady state with 48V output, under all Line and temperature conditions.

### 2. Module High Level Specification Details

Milpower Part Number M4440

Parameter	Functionality
Form factor	3U VPX, VITA 62 compliant 1" pitch
Cooling	Conduction cooled
Power input	28V Line, Mil-STD-704
Power output	48V, 12V, 5.15V, 3.3V, Max 370W
Power Holdup	With M4162 unit.
Management	Advanced I2C FPGA based management.
Temperature	-55C – 85C unit Edge (VITA 47.1 Extended CC4)
Weight	Approx 830g

#### 2.1 Special Features

- VITA 62.0 guidelines
- VITA 47.1 CC4/CCW6 NT4 V3 OS2 C4 AV2 SF1/SF3 CS5
- Wide Input Range
- Up to 370W output power without derating
- 48V Output, separate grounding.
- Remote sense
- Outputs Short Circuit Protection
- Over Temperature Shutdown with Auto Recovery
- Qualified Mil-STD-461-G (5 $\mu$  LISN)

### 3. M4440 Power Supply Operation

#### 3.1 Unit Block Diagram

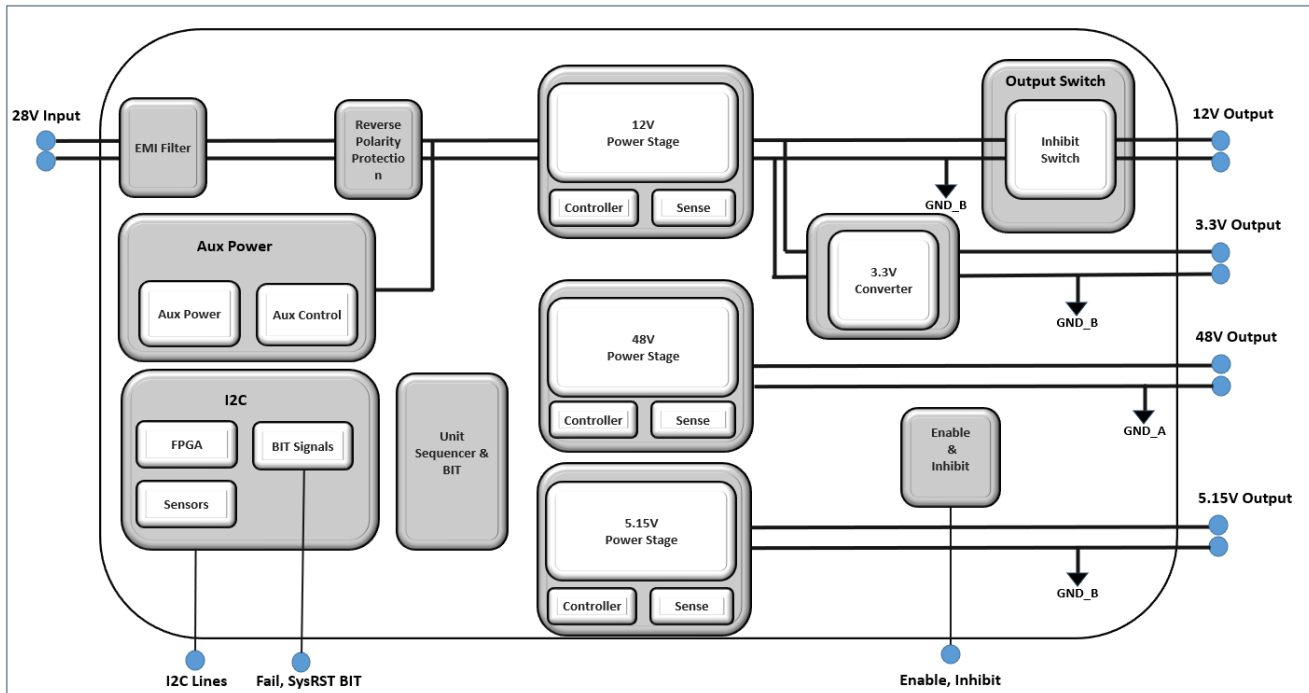

#### M4440 detailed block diagram

## M4440 VPX Power Supply

### 3.2 Electrical Specification

#### DC Input:

- 18V to 48V DC  
(Turn-on at Input voltage below 21V.  
Turn off below 18V) <sup>1</sup>
- Optional: support All Over Voltage  
Transient Up to 100V

#### Notes:

1. Full 704 Compliance at Sec 3.5.1.1
2. When Calling for LISN, 5 $\mu$ H is used

#### DC Outputs:

- Output 1: 48V / 4A
- Output 2: 3.3V / 1A
- Output 3: 12V / 10A
- Output 4: 5.15V / 10A

#### Isolation:

- 200V Input to Output & Chassis.
- 100V output A to Output B
- 100V Output to chassis

#### Line Load Regulation

- 3.3V Output 3.28V to 3.42V,
- 48V Output 47.8V to 48.2V
- 12V Output 11.85V to 12.15V
- 5.15V Output 5.10V to 5.20V

#### Efficiency

Up to 87%.

#### EMC

Mil-STD-461G 5 $\mu$ H LISN<sup>1</sup>  
CE101, CE102, CS101, CS114, CS114, CS115,  
CS116  
Notes: All tests performed with Static resistive  
Load.

#### Ripple and Noise

Typical less than 50mV (max 1%).  
across 0.1 $\mu$ F capacitor with 10  $\mu$ F on Load.  
Note: under all temperature range, Input  
voltage 18V to 36V.

#### System Management Options:

- Advanced I2C Protocol

#### Load Transients

Outputs dynamic response less than 5% for  
Load steps 60% - 90%.  
Output return to regulation <1mSec.

### 3.2.1 Protections

#### Input Current Inrush:

- Bus capacitance  $\approx$  600 $\mu$ F.
- Output Turn-on  
inrush Input current < 1A

#### Outputs Over Voltage

- 12V Active OVP
- 3.3Vaux 3.9V Zener

#### Overload Protection:

Hiccup Over-load / Short Circuit Protection.

#### Input Under /Over Voltage Protection

- Turn-off above 50V.
- Turn-off under 18V.
- Turn-off after 10Sec below 22V.  
Note: T.H can be modified.

#### Over Temperature Protection

Thermal shutdown at Unit  
temperature of 90-105 $^{\circ}$ C.  
Auto Recovery 90 $\pm$ 5 $^{\circ}$ C (unit Edge,  
wedge lock side)

## M4440 VPX Power Supply

### 3.3 Environmental Specification.

#### VITA 47.1 CC4/CCW6 NT4 V3 OS2 C4 AV2 SF1/SF3 CS5

##### Temperature:

- Operational -55C° to 85C° unit edge, -55C° to 71C° cold wall.
  - Exceed Vita 47 CC4.
  - Storage -55C° to 125C°
  - Qualified 600 Thermal Cycles
- Note: Plug-in unit edge surface temperature is measured on the plug-in unit

##### Altitude:

- Mil-STD-810G Method 500.5 procedure I & II
- Storage / Air Transport: 40kft
- Operation / Air carriage: 70kft

##### Rapid Decompression

Designed to meet per Vita 47.1

##### Corrosion Resistance

- Mil-STD-810G, Method 509.5.
- VITA47 Class SF1, SF3
- VITA47 Class SF2 TBD

##### Fungus

Does not support Fungus growth per Mil-HDBK-454, Guideline 4.

##### Humidity

- Mil-STD-810G, Method 507, up to 95% RH.
- Optional:100% condensation, consult factory.

##### Vibration & Shock

- Vita47 Vibration Class V3.
- Vita 47 Operational Shock Class OS2
- Vita 47 Bench Handling Shock (Connector not protected, may be damaged).

##### Reliability

465,000 Hours,  
calculated IAW MIL-HDBK-217F Notice 2  
at +65 °C, GF

##### ESS

Environmental Stress Screening available, please contact factory for details

## M4440 VPX Power Supply

### 3.4 Unit Interfaces

#### 3.4.1 Connectors

<b>Front Panel Connector</b>	Tyco 6450849-7 or equivalent	Main Connector
<b>Mating Connector</b>	Tyco 1-6450869-4 or equivalent	Backplane Connector
<b>Wedge Locks</b>	VA260-4.80T2LK or Equivalent	
<b>Key 1</b>	0°	
<b>Key 2</b>	90°	

## M4440 VPX Power Supply

### 3.4.2 Functions and Signals

Signal Name	Type	Description
FAIL*	Output Open Drain	Indicates to other modules in the system that a failure has occurred in one of the outputs. <sup>1,2</sup> Normally Open.
SYSRESET*	Output Open Drain.	Indicates to other modules in the system that an output voltage is not in its nominal range. <sup>1,2</sup> Normally Open.
INHIBIT*	Input	Controls 12V Output. <sup>1,3</sup>
ENABLE*	Input	Controls 12V, 3.3V Outputs. <sup>1,3</sup>
GAO*, GA1	Input	System addressing per VITA46. <sup>1</sup>
SCL_A, SDA_A	Bi-Direction	Primary I2C lines. <sup>1</sup>
SYNC IN	Input	External Clock for PWM Synchronization. <sup>1</sup>
PO_SENSE	Output	Output Sense line for voltage compensation. <sup>1</sup>
SENSE RETURN	Output	Output Sense return for voltage compensation. Common line for each output group.
SIGNAL RETURN	Passive	Return paths for all signals, refers to Power Return A

#### Notes

- 1 Refers to SIGNAL RETURN
- 2 See para 3.5.3.1 for additional information
- 3 See para 3.5.2.1 for additional information

### 3.5 Power Detailed Description

#### 3.5.1 Input Voltage

##### 3.5.1.1 Operational Input Range

Unit will be fully operational under all steady state condition up to 50V line. Protection or operation through 80V and 100V transients is optional.

Turn -on voltage is under 21V volt, before going into normal steady state.

To protect connector and unit from excess current, Unit can work down to 18V line, with a 10Sec timer once input voltage is lower than 22V.

Detailed Mil-STD-704 is given at table 3.5.1-1 (with restriction per this section above)

Condition	704A	704B	704C	704D	704E	704F
Normal Steady state	Operational					
Abnormal Steady state	Operational					
Emergency Steady state	Operational above 18V / protected below 18V					
Normal Transients	Operational 18V to 50V, 70V optional / protected below 18V	Operational				
Abnormal Transients	Operational 18V to 50V, 80V optional / protected below 18V	Operational above 18V / protected below 18V				
Power Interrupt	Protected / Supports with Holdup unit M4162 (Contact Factory)					
Power Failure	Protected with Auto Recovery					
Reverse Polarity	N/A					Protected

**Table 3.5.1.1-1 Operational Range**

Note:

1. For extended Input Range and working through 16V, 80V & 100V transients or T.H adjustments, please contact factory.

##### 3.5.1.2 Transient Response

Power supply is designed to have a good transient response for input voltage transient.

Output response < 5% for Load transient steps of 60% - 90%.

### 3.5.1.3 *Voltage Distortion*

Design to meet

### 3.5.1.4 *Input Redundancy*

N/A

### 3.5.1.5 *Input Voltage Rise Time*

There is no limitation on Input voltage rise time, contactor connection is supported.

### 3.5.1.6 *Inrush Currents*

Turn-on inrush current can be divided into two categories:

**Bus charge Inrush**, input current is a function of input voltage rise time, charging the 600 $\mu$ F capacitance.

**Outputs Turn-on Inrush**, Input current while outputs turn on, typical lower than 1A above the steady state current.

### 3.5.2 Output Stage

#### 3.5.2.1 Output Controls: Enable & Inhibit Signals

Outputs are controlled by Enable and Inhibit Signals per VITA 62 definition.

See Table 3.5.2.1-1

INHIBIT*	Low	Low	High	High
ENABLE*	Low	High	Low	High
All Outputs	OFF	OFF	ON	OFF
3.3V Aux Output	ON	OFF	ON	OFF

Table 3.5.2.1-1 Outputs Truth table per Signal Status

#### 3.5.2.2 Output Power

Standard configuration will support 48V/4A, 12V/10A, 5.15V/10A and 3.3VAux/15A with up to 2mF capacitance on each output. No Power derating is required for current share application.

**Note:** for extended output capacitance, please contact factory.

#### 3.5.2.3 Voltage regulation and Ripple

Voltage regulation and ripple are measured as sense point location and limits are under all operational range (Line, Load, Temperature).

Voltage is measured at connector output, Sense line shorted to output.

- 3.3V Output 3.28V to 3.42V,
- 48V Output 47.8V to 48.2V
- 12V Output 11.85V to 12.15V
- 5.15V Output 5.10V to 5.20V

#### Notes:

1. limits for 18V-36V Input, under all Loads and Temperature condition
2. Ripple is measured on load after 3-feet harness across 0.1 $\mu$ F capacitor with 10  $\mu$ F on Load (20MHz BW).

#### 3.5.2.4 Turn-on & Sequencing

Configurable output sequencing

### **3.5.2.5 Sense Connection**

Sense lines are provided for all outputs sense line with a single SENSE RETURN signal for each power group.

*Unit sense circuit can compensate up to 0.4V at full load*

### **3.5.2.6 Dynamic Response**

*Typical performance of 5% output response during a 60% to 90% load dynamic response*

**3.5.2.7 Current Share**

N/A

**3.5.2.8 Short Protection**

All outputs have an indefinite hiccup for over-Load / short circuit protection.  
While output is at hiccup mode, current during on-time may exceed 140% of max current

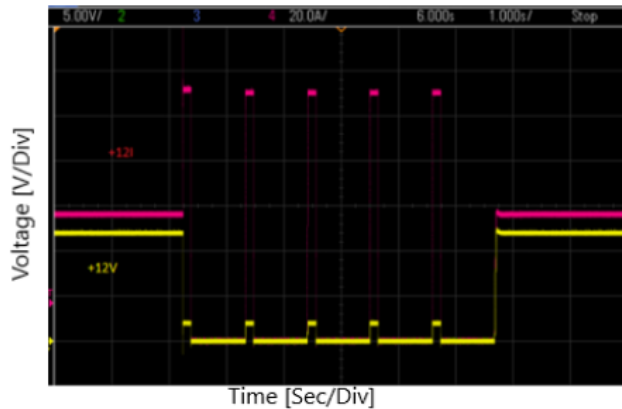
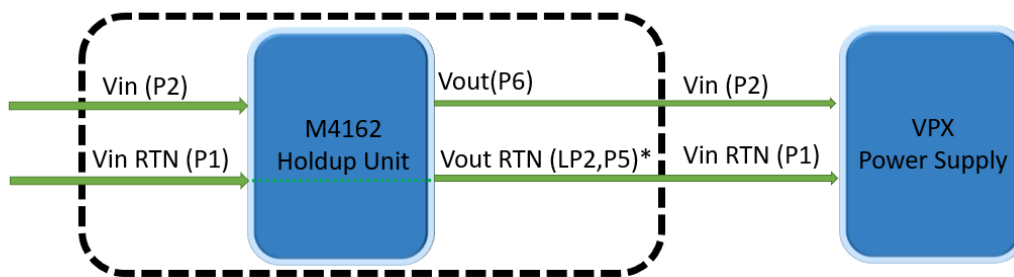

Figure 3.5.2.8-1 Typical 12V Output hiccup and recovery after short

**3.5.2.9 Hold-up**

Requires M4162 unit.  
Contact factory for choosing the correct part number.



### 3.5.3 Signals

#### 3.5.3.1 Fail bit & SYSTEM RESET

Unit has two dedicate Fault signals:

**Fail BIT:** Indicates that one of the power supply outputs is out of its range, in respect to the expected value depending on Inhibit & Enable status.

Open drain output (Per VITA 65), Normally Open and goes Low during Fail event.

**SYSTEM RESET:** Indicates that one of the power supply outputs is out of its nominal range.

Open drain output (Per VITA 65), Normally Open and goes Low when output is out of nominal range.

Note: for the M4440 this BIT standard configuration is as “Output”.

### 3.5.3.2 SYNC IN

*External clock for synchronization, please contact factory*

### 3.5.4 Built In Tests

For proper operation, the unit has Built In Test circuit, which continuously monitors Unit's internal functions, such as: Input Voltage, Internal Aux voltage, Temperature, Output voltages and control proper Turn-on and Turn-off Sequence.

Turn on: verification that all parameters are withing proper and all Aux voltage are stabilize before starting outputs Turn-on sequence.

Continues: Monitoring all critical parameters and initiating a controlled Turn-off sequence when required.

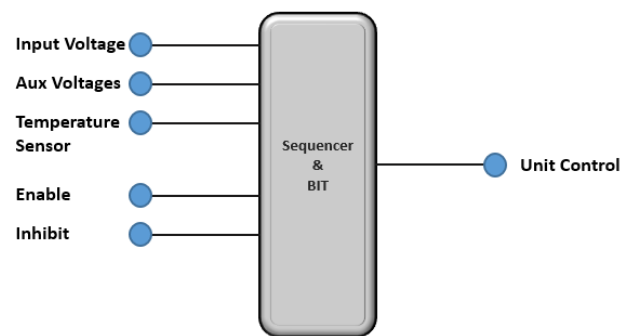

### 3.5.5 Thermal Management

Operational Temperature range is  $-55^{\circ}\text{C}$  to  $+85^{\circ}\text{C}$  on the surface of the edge that contacts the rack/enclosure. The contacting surface on the rack needs to be at lower temperature to account for thermal resistance between the unit and the chassis/cold plate. The M4440 wedge locks are defined as  $0.3^{\circ}\text{C}/\text{W}$  Resistance per Card Edge. The thermal design of the unit will provide a balanced power dissipation between both sides of the unit.

The unit has two thermal sensors.

Analog Thermal Sensor for protection and shutdown. Shutdown temperature would be between  $90^{\circ}\text{C}$  to  $105^{\circ}\text{C}$  at unit edge, load depended.

No power derating is required for all operational temperature range

### 3.6 System Management

#### 3.6.1 Electrical Interface

<b>Pullups</b>	<b>10KΩ</b>
<b>Capacitance</b>	<b>330PF</b>
<b>Vcc</b>	<b>3.3V</b>

#### 3.6.2 Communication Protocol

The M4440 can support Advanced I2C protocol.

Slot location, is defined by VITA62. See table 3.7.2-1.

The following data Sensors are available:

Output Current sensors: Max error of +/-5% or up to +/-1A (the bigger of the two)

Output Voltage sensors: Max error up to +/-0.2V

Input Voltage sensors: Max error up to +/-1.5V

Temperature sensors: ±5C (Internal measurement).

Slot Number	A6	A5	A4	A3	A2/GA2*	A1/GA1*	A0/GA0*	Hardware Address	IPMB
Slot0	0	1	0	0	0 / U	0 / U	0 / U	20	40
Slot1	0	1	0	0	0 / U	0 / U	1 / G	21	42
Slot2	0	1	0	0	0 / U	1 / G	0 / U	22	44
Slot3	0	1	0	0	0 / U	1 / G	1 / G	23	46

**Table 3.7.2-1 Address Space**

**Note:** A0÷A6 represent Firmware address and GAx represent the physical Geographical Address.

**U = Unconnected; signal is pulled-up on the unit and result as logic "0"**

**G = Biased to Ground on the Backplane; results in a logical "1"**

**3.6.2.1 Advanced I2C Protocol**

This communication protocol serves as optional when 46.11 compatible ChM is not used. Communication supports read command.

**Read Command** – 21Hex, deliver 64Bytes of Data.

The communication starts when the master sends a start followed by the unit slave address, command, checksum and a stop. A second start followed by the slave address and a read will be followed by a 64 Bytes response.

S	Slave Address	R/W	A	Command	A	Check sum	A	P
	A6:A0	0	0	21 Hex	0	DF Hex	0	

W

S	Slave Address	R/W	A	DATA	A	DATA	A	DATA	A	DATA	A	Check sum	N/A	P
	A6:A0	1	0	D7:D0	0	D7:D0	0	D7:D0	0	...	0	D7:D0	1	

Command – 21Hex read all 64 Bytes

S - Start

P - Stop

Master Transmit	Unit Transmit

## 3.7 Pinout

<i>Pin Number</i>	<i>Pin Name (12V Only)</i>
P1	-DC_IN/ACN
P2	+DC_IN/ACL
LP1	CHASSIS
P3	5.15V/10A
P4	POWER_RETURN_A
P5	POWER_RETURN_B
LP2	12V/10A
P6	+48VDC
A8	SENSE, +48VDC
B8	SENSE, 3.3V_AUX
C8	SENSE, +12VDC
D8	SENSE_RETURN_B
A7	N.C.
B7	3.3V_AUX_Sense
C7	SENSE_RETURN_A
D7	SIGNAL_RETURN
A6	N.C.
B6	N.C.
C6	N.C.
D6	SYSRESET*
A5	GA0*
B5	GA1*
C5	SM0
D5	SM1
A4	3.3V_AUX
B4	3.3V_AUX
C4	3.3V_AUX
D4	3.3V_AUX
A3	N.C.
B3	N.C.
C3	N.C.
D3	N.C.
A2	N.C.
B2	FAIL*
C2	INHIBIT*
D2	ENABLE*
A1	N.C.
B1	N.C.
C1	N.C.
D1	N.C.

# M4440 VPX Power Supply

## 3.8 Mechanical SCD

