

M4703 SERIES

DC/DC POWER SUPPLY



PRODUCT HIGHLIGHTS

- VITA 62 COMPLIANT
- 6U VPX FORM FACTOR
- SOSA™ ALIGNED
- DC/DC CONVERTER
- Up to 1200W Steady State
- Cyber Secure

Description

1.1

M4703 is a military grade 6U VPX, SOSA™-aligned power supply that provides 12V and 3.3VAUX per VITA 62 that is rated at 1200W output power. Features include: conduction cooling, 1" pitch, current-sharing, internal EMI filters, VITA 46.11 system management. DC input is 270V per MIL-STD-704. Designed to meet MIL-STD-810 and MIL-STD-461.

M2192 Series– DC/DC Power Supply

Applications

Military (Airborne, ground-fix, shipboard), Ruggedized, Telecom, Industrial

Special Features

- VITA 62 6U
- SOSA™ Aligned
- High efficiency
- Input / Output isolation
- Remote sense
- EMI filters included
- Fixed switching frequency
- Parallel configuration
- 46.11 Tier 2 communication
- External Inhibit & Enable
- Indefinite short circuit protection with auto-recovery
- Over temperature shutdown with auto recovery

Electrical Specifications

DC Input

270 V_{DC}

- Works Through MIL-STD-704 (B-F) Normal and Abnormal Steady State.
- Works Through MIL-STD-704(E-F) Normal transients
- Protected MIL-STD-704(B-D) Normal/Abnormal Transients
- Protected MIL-STD-704(E-F) Abnormal Transients
- Optional: Works Through MIL-STD-704(E-D) Abnormal Transients

Line/Load regulation

±1% or better (no load to full load, low line to high line (–55°C to 85°C).

Ripple and Noise

Less than 50mV_{p-p}, typical (max. 1%), measured across 0.1µF and 10µF on Load

System Management Options

- 1) I2C
- 2) VITA 46.11 Tier II IPMC

Data available:

- Output voltages and currents
- Input voltage
- Card temperature
- Card status

Notes:

¹ Contact Factory for peak power options

² RE102 Supported at system Level

DC Outputs

PO1/PO2/PO3 12V/90A

3.3V_{aux} 3.3V/20A

Total Steady state Power 1200W (–55°C to +85°C).

Hold Up

N/A

Current Share

12V Active Current share
3.3V_{aux} Passive Current Share (3.3V_{aux} ACS optional)

Load Transient

Output dynamic response up to 5% at step load of 30%-90%.

Output return to steady stated within 300-500µSec

Power Factor

N/A

Isolation

500V_{DC} Input to Output

500V_{DC} Input to Case

500V_{DC} Output to Case

EMC

Designed to meet MIL-STD-461F² CE102, CS101, CS114, CS115 & CS116, CS117 RE102

Efficiency

Typical 89% (Nominal line, nominal load, room temperature)

M2192 Series– DC/DC Power Supply

Protections (Thresholds and protections can be modified / removed – please consult factory).

Input

- **Inrush Current Limiter:**
peak value of $5 \times I_{IN}$ for inrush currents lasting longer than 100 μ s.
- **Under Voltage Lock-Out**
Unit shuts down when input voltage is below 190Vdc \pm 5Vdc.
- **Catastrophic Failure Protection**
Fuses are available to protect from catastrophic failure. The fuses are rated not to engage due to any normal type operation.

Outputs

- **Over Voltage Protection:** 12V
Active & Passive OVP 3.3Vaux
Active & Passive OVP
- **Overload / Short Circuit Protection**
12V&3.3Vaux Output-Continuous
Hiccup protection (110-130%).

General

- **Over temperature Protection:**
Shutdown at +100 °C \pm 5°C
Recovery at +90 °C \pm 5°C
Temperature measured at Unit edge.

Environmental

Designed to meet MIL-STD-810G and VITA 47

Temperature

Operating: –55°C to +85°C (at plug-in card edge, IAW VITA 62 CC4) Storage: –55°C to +125°C

Altitude

810G Method 500.5, Procedure II (Operational) & VITA 47 para. 5.7 60,000 ft.

Salt Fog

Method 509.5

Humidity

810G Method 507.5 & VITA 47 Para. 5.6, Up to RH 95%.

Vibration

810G Method 514.6 Procedure I. General minimum integrity exposure.
(1 hour per axis
& VITA 47 Vibration Class V3

Shock

810G Method 516.6 Procedure I & VITA 47 Shock Class OS2 Saw-tooth, 40g peak, 11ms

Reliability

> 314,000 hours, calculated per MIL-STD-217F Notice 2 at +65°C at wedge lock edge, Ground Fixed.

Fungus

Does not support fungus growth, in accordance with the guidelines of MIL – STD – 454, Requirement 4.

Environmental Stress Screening (ESS)

Including random vibration and thermal cycles is also available. **Please consult factory for details.**

M2192 Series– DC/DC Power Supply

Functions and Signals (according to VITA 62.0)

Signal Name	Type	Description
FAIL*	Output	Indicates to other modules in the system that a failure has occurred in one of the outputs. Please refer to Figure 2
SYSRESET*	Output	Indicates to other modules in the system that all outputs are within ¹ their working level. Please refer to Figure 2
INHIBIT*	Input	Controls power supply outputs. This signal in conjunction with Enable controls the outputs. Please refer to Table 1 and Figure
ENABLE*	Input	Controls power supply outputs. This signal in conjunction with INHIBIT controls the outputs. Please refer to Table 1 and Figure 1
GA0-4*, GAP*	Input	Used for geographical addressing. GA4 is the most significant bit and GA0 is the least significant bit.
SCL, SDA	Bidirectional	I2C bus Clock and Data respectively. Through this bus the voltage and temperature readouts can be shared.
Sync In	Input	The Sync signal is used to allow the power supply frequency to sync with the system frequency. (Optional)
Sync Out	Output	Send Internal switching frequency. (Optional)
VOUT SENSE	Input	The SENSE is used to achieve accurate load regulations at load terminals (this is done by connecting the pins directly to the load's terminals).
12VCS	Bidirectional	Support current share between Outputs. Two pins required. ^{1 2}
12V ACS	Bidirectional	Support Active current share between Outputs. See Current Share para. ^{1 2}
3.3Vaux CS	Bidirectional	Support current share between Outputs. See Current Share para. ^{1 2}
3.3Vaux ACS	Bidirectional	Support Active current share between Outputs. See Current Share para. ^{1 2 3}

Notes:

¹ All Signals referenced to **SIGNAL RTN**

² When not used leave open

³ Non-SOSA™ configuration

Table 1 – Inhibit and Enable Functionality

INHIBIT*	Low	Low	High	High
ENABLE*	Low	High	Low	High
12V Output	OFF	OFF	ON	OFF
3.3V_AUX	ON	OFF	ON	OFF

Figure 1 – Inhibit and Enable Input stage

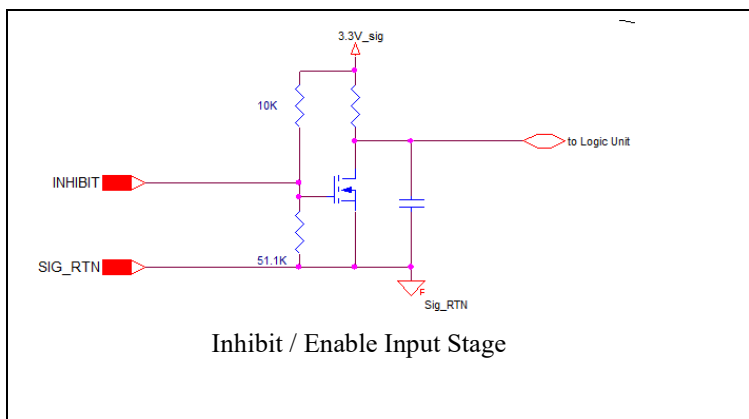
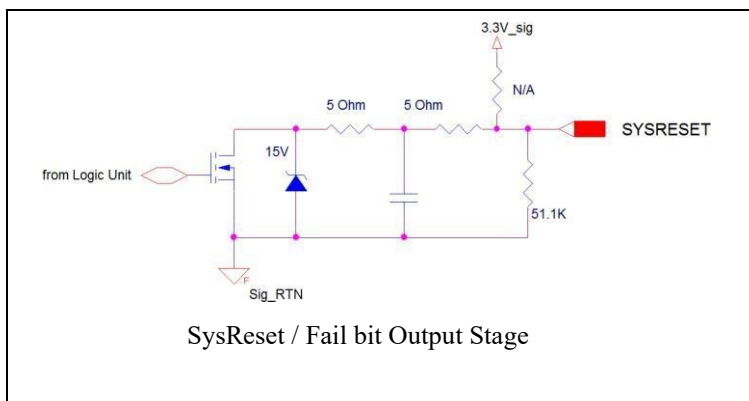

Figure 2 – SysRst and Fail Bit Output Stage



Detailed Information

1. Input Voltage Operation.

The M4703 steady state operation is per Mil-STD-704. Unit will work through all Normal Transients per Mil- STD-704 B to F, protected to all other transients and interrupts.

2. Outputs Voltage Regulation

The M4703 contains accurate internal sense lines to keep output voltage at less than 3% regulation for all Line / Load and temperature range (see Table 2).

The M4703 contains three 12V sense line pairs. These sense lines are all shorted together internally. For proper operation, connect only a single sense line to the point of load regulation. The same recommendation applies to the sense return line.

For proper current shared operation, connect a single sense line from each M4703 to the same point of load regulation.

Output	12V Output	3.3Vaux Output
Voltage Range	11.85 – 12.15	3.25 – 3.4

Table 2: Outputs voltage regulation. Temperature -55°C – 85°C

Figure 3 – Sense Lines connection

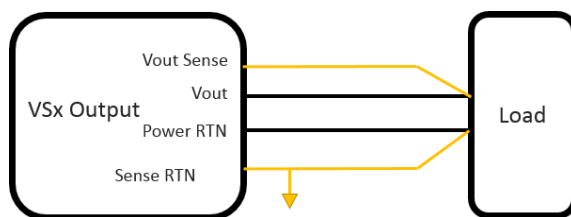

3. Current Share (C.S)

Current Share of two or more units is optional (Contact Factory)
12V output and 3.3VAux will current share with about 2-4A load balance.

3.1 Active Current Sharing (A.C.S)

Current share done in a closed-loop. All paralleled outputs are compared and feedback is used to balance their load current. The result is a more stable, less sensitive output voltage without voltage drop. Typical Load Balance of about 1 to 4A for all Load range is expected.

ACS is supported by the 12V output. Optional for 3.3Vaux^{1 2}.

3.2 3.3Vaux Passive current sharing (P.C.S)

Current sharing is done in open loop, output voltage drops as a function of output load. Load Balance of about 5-10% is expected. 3.3Vaux ACS is optional^{1 2}

3.3 Current share connection between two Units.

For a required output to current share please connect the following Pins between the two units

- PO#_Sense & PO#_Sense_RTN (for best performance, Pins from paralleled units should be connected to a single point and as close as possible to the load point)
- Connect A7, B7 AND C7 to corresponding pin between units (A7 to A7, etc.)
- Connect B1 for 3.3Vaux ACS (Optional, not per SOSA pinout. This pin is internally N.C if not ordered)

When not used, all share pins can be left open.

Figure 4 -Typical ACS Dynamic Load of Two 12V Paralleled Outputs

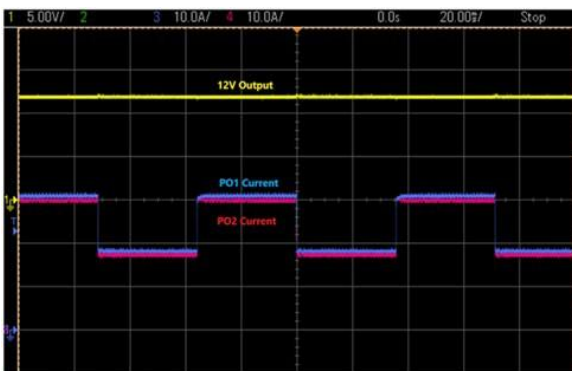

Notes:

¹ When not used, share pins can be left open.

² When ordering 3.3Vaux P.C.S or Non-Current Share unit, those pins are Internally disconnected

M2192 Series– DC/DC Power Supply

4. Communication Protocol

Unit communication protocol can be configured as VITA 46.11 Tier 2 IPMC, VITA 46.11 Tier 1 IPMC or Advanced I2C protocol. For more details on protocols refer to para. 5.1 and 5.2

4.1 Advanced I2C Protocol

Electrical Parameters

Vcc	3.3VDC
Pull-up	20kOhm
Input capacitance	100pf

Slave Device Addressing

- 256 address spaces
- Baud rate: 200kHz maximum
- 7 Bit Protocol
- Support Slot Addressing per VITA 62

	MSB							LSB
Slot Number	A6	A5/*GAP	A4/*GA41	A3/*GA3	A2/*GA2	A1/*GA1	A0/*GA0	R/W
Slot0	1	0	0	0	0	0	0	
Slot1	1	0	0	0	0	0	1	
Slot2	1	0	0	0	0	1	0	
Slot3	1	0	0	0	0	1	1	

* Slot location is determined by GAx per VITA 62.

2. Communication Supported

3. Read Command – 21Hex, deliver 64Bytes of Data. (More commands are available by request) The communication starts when the master sends a start followed by the unit slave address, command, checksum and a stop. A second start followed by the slave address and a read will be followed by a 64 Bytes response.

S	Slave Address	R/W	A	Command	A	Check sum	A	P
	A6:A0	0	0	21 Hex	0	DF Hex	0	

S	Slave Address	R/W	A	DATA	A	DATA	A	DATA	A	...	DATA	A	Check sum	N/A	P
	A6:A0	1	0	D7:D0	0	D7:D0	0	D7:D0	0		D7:D0	0	D7:D0	1	

Command -21Hex read all 64 Bytes

S- Start

P-Stop

Master Transmit	Unit Transmit
-----------------	---------------

M2192 Series– DC/DC Power Supply

Memory Space

Response Byte #	Data Type	Meaning	Interpretation	Reading Range
0	U Integer, MSB First	Echo of Command		21 Hex
1	U Integer, MSB First	N/A		00 Hex
2	S Integer, MSB First	Temperature	T(C°)=+/- 7bit Dec	-55 to 125 °C
3	U Integer, MSB First	Reserved	00Hex	
4-5	U Integer, MSB First	PO1 12V Voltage	V(out) = Data/ m2	20.48V
6-7	U Integer, MSB First	PO2 12V Voltage	V(out) = Data/ m2	20.48V
8-9	U Integer, MSB First	PO3 12V Voltage	V(out) = Data/ m2	20.48V
10-11	U Integer, MSB First	3.3V Aux Voltage	V(out) = Data/ m2	20.48V
12-13	U Integer, MSB First	12VAux Voltage	V(out) = Data/ m2	Optional
14-15	U Integer, MSB First	(-)12V Aux Voltage	V(out) = Data/ m2	Optional
16-17	U Integer, MSB First	12V Total Current	V(out) = Data/ m3	140A
18-19	U Integer, MSB First	12V Total Current - Copy	V(out) = Data/ m3	140A
20-21	U Integer, MSB First	12V Total Current - Copy	V(out) = Data/ m3	140A
22-23	U Integer, MSB First	3.3VAux Current	V(out) = Data/ m5	20A
24-35	U Integer, MSB First	12V Aux Current	V(out) = Data/ m4	Optional
26-27	U Integer, MSB First	(-)12V Aux Current	V(out) = Data/ m4	Optional
28-29	U Integer, MSB First	Reserved	00Hex	
30-31	U Integer, MSB First	Reserved	00Hex	
32-51	Character String (ASCII)	Part Number	M4703-xxx* (Note1)	20 Characters
52-53	Decimal, MSB First	Serial Number, 2MSB Dig	X,X Dec (Note2)	Optional
54-55	Decimal, MSB First	Serial Number, 2LSB Dig	X,X Dec (Note2)	Optional
56-57	Decimal, MSB First	Date Code	Week, Year (Note3)	Optional
58-59	Character String (ASCII)	Hardware Rev	B01 & B02 Boards (note4)	2 Characters
60-61	Decimal, MSB First	Firmware Rev	X,X,X,X Dec (Note5)	4 digits
62	U Integer, MSB First	Reserved		AA Hex
63	U Integer, MSB First	Zero Checksum	Value required to make the sum of bytes 0 to 62 added to a multiple of 256	

Note:

$$M_2=20.48 / 2^{16-1}$$

$$M_3=140 / 2^{16-1}$$

$$M_4=10 / 2^{16-1}$$

$$M_5=20 / 2^{16-1}$$

*Matching unit part number

M2192 Series– DC/DC Power Supply

Notes 1 to 5:

1. Part Number Example: M4065-4
- 2.

Byte No'	32	33	34	35	36	37	38	39-51
Character	M	4	0	6	5	(-)	4	0
Hex	4D	34	30	36	35	2D	34	00

3. Serial Number Example: 25

Byte No'	52		53		54		55	
Dec Number	0	0	0	0	0	0	2	5
Binary	"0000"	"0000"	"0000"	"0000"	"0000"	"0000"	"0010"	"0101"

4. Date Code Example: week 35 of 2018

Byte No'	56		57	
Dec Number	3	5	1	8
Binary	"0011"	"0101"	"0001"	"1000"

5. Hardware Rev Example: B01 Rev (-), B01 Rev A

Byte No'	58	59
Character	(-)	A
Hex	2D	41

6. Firmware Rev Example: 2.1.0.0

Byte No'	60		61	
Dec Number	2	1	0	0
Binary	"0010"	"0001"	"0000"	"0000"

M2192 Series– DC/DC Power Supply

4.2 VITA 46.11 Tier 1 and Tier 2 IPMC

Please see 46.11 User Manual for detailed information of operation. Sensors included are seen in the table below.

Record ID	Sensor ID	Sensor Type	Name
0000	00	F0h	FRU State Sensor
0001	01	F1h	System IPMB Link Sensor
0002	02	F2h	FRU Health Sensor
0003	03	02h	FRU Voltage Sensor
0004	04	F3h	FRU Temperature Sensor
0005	05	F4h	Payload Test Results Sensor
0006	06	F5h	Payload Test Status Sensor
0100	07	02h	VS1 Voltage
0103	0A	02h	3.3VAux Voltage
0106	0D	03h	VS1 Current
0109	10	03h	3.3VAux Current
010C	13	01h	Analog Temperature
010D	14	01h	Analog Temperature 2
9999	N/A	N/A	Device Management

M2192 Series– DC/DC Power Supply

Block diagram

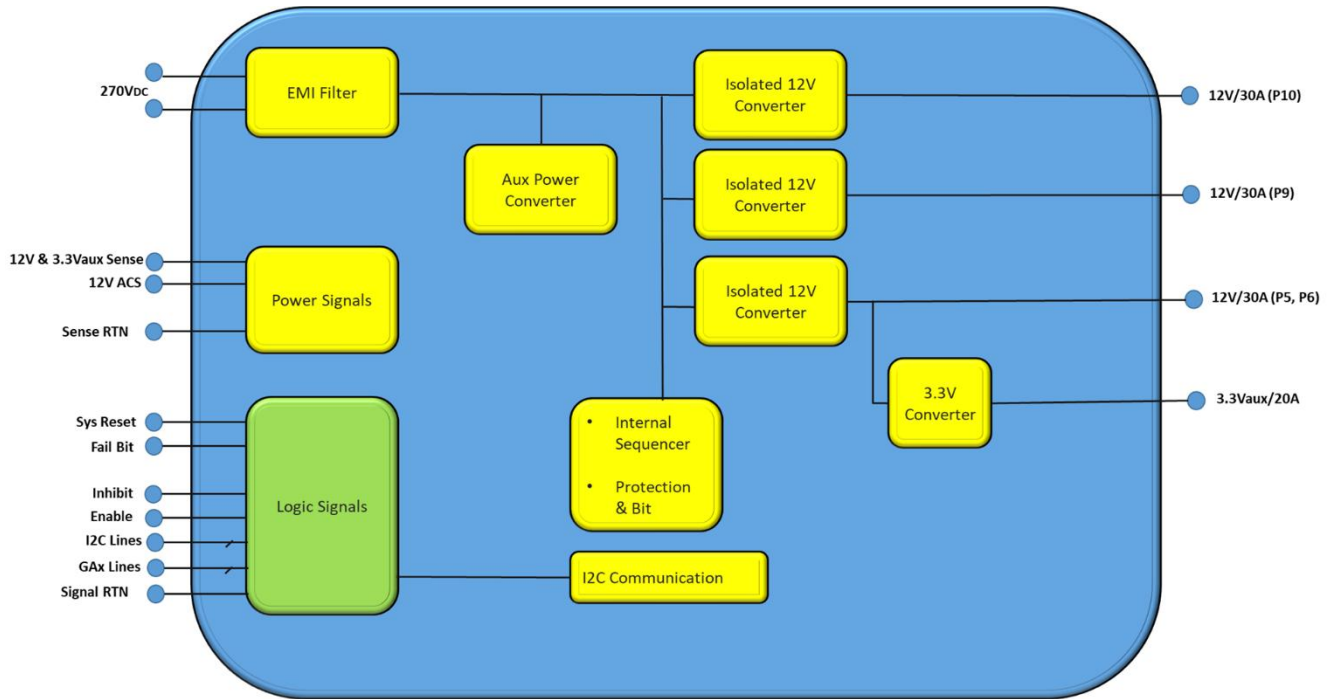

M2192 Series– DC/DC Power Supply

5. Pin Assignment

Connector P1: Connector type: 6450849-6 or

Connector P0

Connector type: 2348886-1 or eq.

Pin Number	Pin Name
P10	12V/35A (VS1, VS2)
P9	12V/35A (VS1, VS2)
A9	12V_SENSE
B9	12V_SENSE
C9	12V_SENSE
D9	Sync in
A8	12V_SENSE_RTN
B8	12V_SENSE_RTN
C8	12V_SENSE_RTN
D8	Sync Out
A7	12V_CS
B7	12V_ACS
C7	3.3Vaux_CS
D7	SIGNAL_RETURN
P8	POWER_RETURN
P7	POWER_RETURN
A6	SCL_B
B6	SDA_B
C6	-12V_AUX / N.C
D6	SYSRESET*
A5	GAP*
B5	GA4*
C5	SCL
D5	SDA
A4	GA3*
B4	GA2*
C4	GA1*
D4	GA0*
A3	N.C
B3	+12V_AUX/N.C
C3	N.C
D3	N.C
P6	12V/35A (VS1, VS2)
P5	12V/35A (VS1, VS2)
P4	POWER_RETURN
P3	POWER_RETURN
A2	N.C
B2	FAIL*
C2	INHIBIT*
D2	ENABLE*
A1	N.C
B1	3.3Vaux ACS
C1	3.3Vaux Sense
D1	3.3Vaux Sense return
P2	3.3V/15A
P1	POWER_RETURN

Pin Number	Signal Name
P7	+DC
P6	+DC
P5	-DC
P4	-DC
P3	
P2	
P1	CHASSIS_GND

Notes:

- P5,P6 are shorted internally.
- P10,P9 are not shorted internally.
- P10 or P9 are not shorted internally to P5,P6.

M2192 Series– DC/DC Power Supply

Outline Drawing

For detailed dimensions and tolerances see Drawing: M4703001 Rev 1

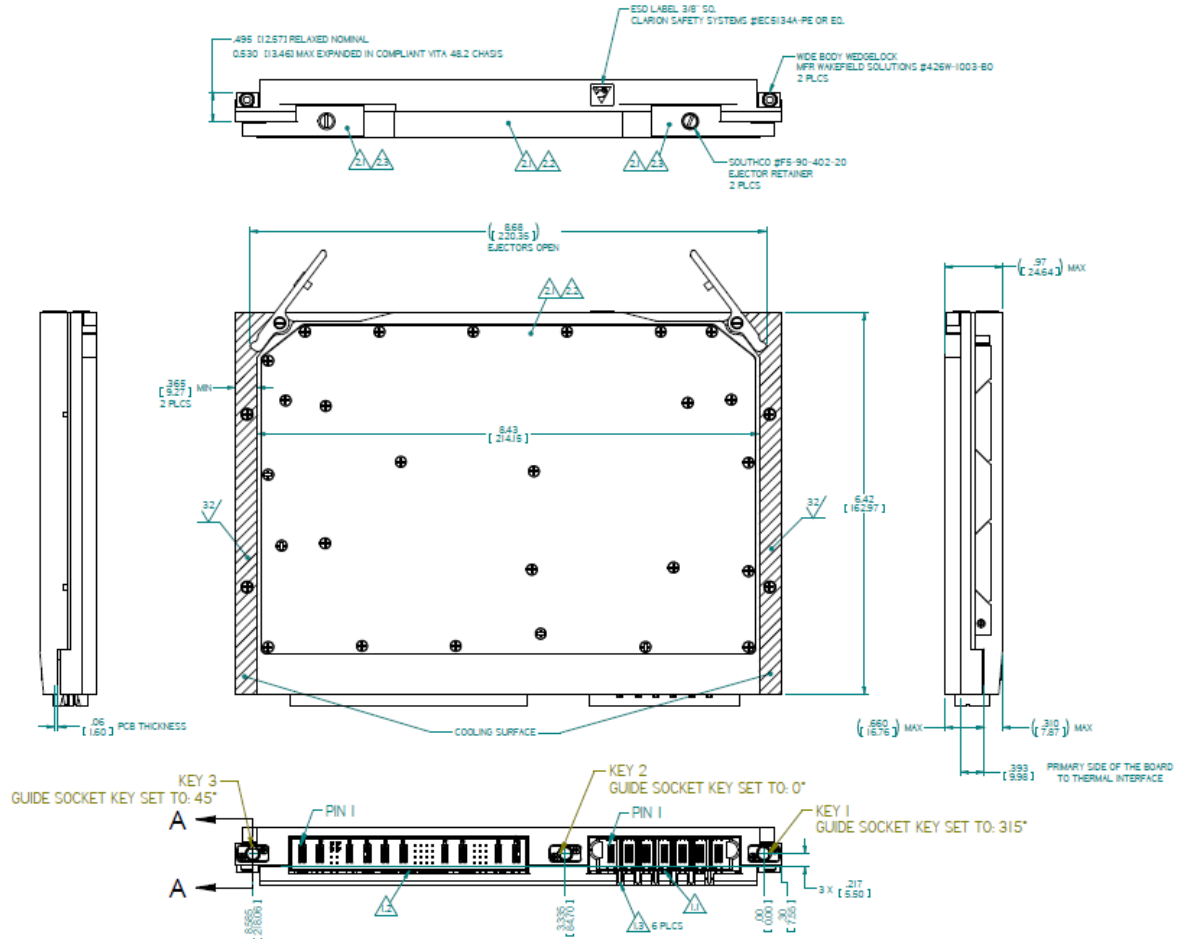

M2192 Series– DC/DC Power Supply

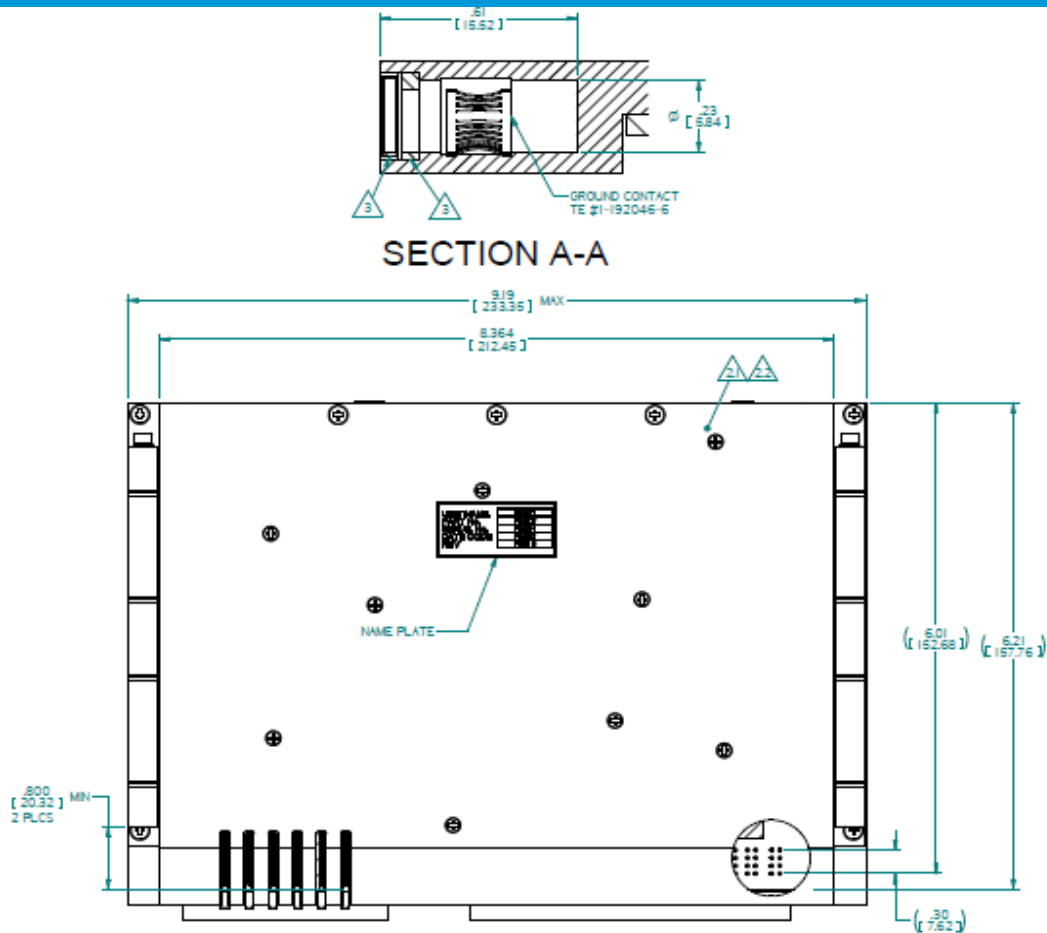

NOTES :

1. CONNECTOR AND BARRIER:
 - 1.1: TYCO P/N 2348886-1 OR EQ.
MATES WITH: TYCO P/N 2348888-1.
 - 1.2: TYCO P/N 6450849-6 OR EQ.
MATES WITH: TYCO P/N 1-6450869-0.
 - 1.3: BARRIER INSERT, TYCO P/N 2313445-1.
2.
 - 2.1 MATERIAL: ALUMINUM 6061-T651
 - 2.2 FINISH: CONVERSION COAT PER MIL-DTL-5541, TYPE I or II, CLASS 1A.
 - 2.3 FINISH:BLACK ANODIZE PER MIL-A-8625, TYPE II, CLASS 2
3. MATERIAL: 303 PER ASTM A895/A582
OR 304 PER ASTM A240/A276
FINISH: SAE AMS 2700 TYPE II PASSIVATE
4. WORKMANSHIP SHALL BE MIL-STD-454, REQ. 9
5. Weight Approx. 4 lbs.

* Specifications are subject to change without prior notice by the manufacturer.