

M6203 SERIES

DC/DC POWER SUPPLY



PRODUCT HIGHLIGHTS

- HIGH EFFICIENCY
- SINGLE OUTPUT
- HIGH VOLTAGE
- DC/DC POWER SUPPLY
- UP TO 500 W

M6203 SERIES DC/DC POWER SUPPLY

Applications

Military (Airborne, ground-fix, shipboard), Ruggedized, Telecom, Industrial

Special Features

- Miniature size
- High efficiency
- High density – up to 35.6 W/in³
- Wide input range
- Input / Output isolation
- EMI filters included
- Fixed switching freq. (250 kHz)
- External sync. capability
- Inrush current limiter circuit
- Remote ENABLE (On/Off)
- Remote sense compensation
- Non-latching protections:
 - Reverse input polarity
 - Overload/short-circuit
 - Output overvoltage
 - Input UVLO/OVLO
 - Over temperature

Electrical Specifications

DC Input

Normal range: 200-350V_{DC}
Wider range possible – **consult factory**

Output Voltage Regulation

Less than ±1%
(no load to full load; across input voltage range; –55°C to +85°C baseplate temperature).

Ripple and Noise:

Less than 50mV_{p-p}, typical (max. 1% without external capacitance. When connected to system capacitance ripple drops significantly).

DC Output

Voltage range: 3.3 to 50 V_{DC}
Current range: 0 to 30 A
Power range: 0 to 500 W

Efficiency

Typical 88-90%
(28V_{DC} output, full load, room temperature)

Transient Over-and-undershoot

Output resistance at load change of 50%-100% is 30-200 mΩ (depending on output voltage).
Output back to steady stated within 300-500 μs.

Isolation

Input to Output: 500 V_{DC}
Input to Case: 500 V_{DC}
Output to Case: 200 V_{DC}

EMC

Designed to meet MIL-STD-461F*
CE101, CE102, CS101, CS114, CS115, CS116, RE101, RE102, RS101, RS103

Turn-On Transient

No overshoot.

Protections *

Input

- **Inrush Current Limiter**
- **Reverse Polarity Protection**
No damage (unlimited time)
- **Under Voltage Lock-Out**
Unit turns off below 200 V_{DC}.
- **Over Voltage Lock-Out**
Unit turns off above 380 V_{DC}

Output

- **Active Over Voltage Protection**
Internal control shuts down unit 10 ± 5% above nominal voltage.
- **Passive Over Voltage Protection**
Transorb protects unit and load 20 ± 10% above nominal voltage.
- **Current limiting**
Output shuts down and attempts to restart periodically, until fault condition removed (hiccup).

General

- **Over temperature protection**
Unit shuts down if baseplate temperature exceeds +105 ± 5 °C.
Automatic recovery upon cooldown to below +95 ± 5 °C.

* EMC compliance achieved when tested with 5 μH LISNs, shielded harness and static resistive load.

M6203 SERIES DC/DC POWER SUPPLY

Environmental Conditions

Designed to Meet MIL-STD-810F

Temperature

Methods 501.4 & 502.4

Operating: -55°C to +85°C (at baseplate)

Storage: -55°C to +125°C (ambient)

Altitude

Method 500.4

Procedures I – Storage/Air transport:
up to 70,000 ft. (non-operational)

Procedure II – Operation/Air Carriage:
up to 55,000 ft. (operational)

Humidity

Method 507.4

Up to 95% RH

Vibration

Method 514.5

Procedure I, Category 24

General minimum integrity exposure

IAW Figure 514.5C-17

1 hour per axis.

Shock

Method 516.5

Procedure I

20 g / 11 ms terminal peak sawtooth shock
pulse

Salt Fog

Method 509.4

Reliability

150,000 hours, calculated IAW MIL-HDBK-217F Notice 2 at +85°C baseplate, Ground fixed conditions.

* Thresholds and protections can be modified / removed – please consult factory

M6203 SERIES DC/DC POWER SUPPLY

Pin Assignment

Connector type: Positronic ODD44M40000/AA-50 or eq.

Mates with: Positronic DD44S1000C or eq.

Pin #	Function	P
1	OUTPUT	+
2	OUTPUT	+
3	OUTPUT RTN	-
4	OUTPUT RTN	-
5	OUTPUT	+
6	OUTPUT	+
7	OUTPUT RTN	-
8	OUTPUT RTN	-
9	OUT GOOD	+
10	SIGNAL RTN	-
11	N.C.	
12	N.C.	
13	INPUT RTN	-
14	N.C.	

Pin #	Function	P
15	INPUT	+
16	OUTPUT	+
17	OUTPUT	+
18	OUTPUT RTN	-
19	OUTPUT RTN	-
20	OUTPUT	+
21	OUTPUT	+
22	OUTPUT RTN	-
23	OUTPUT RTN	-
24	SENSE RTN	-
25	ENABLE	+
26	N.C.	
27	N.C.	
28	INPUT RTN	-

Pin #	Function	P
29	N.C.	
30	INPUT	+
31	OUTPUT	+
32	OUTPUT	+
33	OUTPUT RTN	-
34	OUTPUT RTN	-
35	OUTPUT	+
36	OUTPUT	+
37	OUTPUT RTN	-
38	OUTPUT RTN	-
39	SENSE	+
40	SYNC	+

* All output parallel pins should be connected together for best performance.

M6203 SERIES DC/DC POWER SUPPLY

Functions and Signals

ENABLE

The ENABLE signal is used to turn the power supply ON and OFF.
 TTL "0" or SHORT - For normal operation connect to GND
 TTL "1" or OPEN – will turn off the power supply.

SYNC

The SYNC IN signal is used to allow the power supply frequency to sync with the system frequency.
 The system frequency should be 250 kHz \pm 10 kHz.
 When not connected the power supply will work at 250 kHz

SIGNAL RTN

The INPUT SIGNAL RTN is used as grounding for SYN IN, ENABLE, and OUT GOOD signals.

SENSE

The SENSE is used to achieve accurate load regulations at load terminals (this is done by connecting the pins directly to the load's terminals).
 The use of remote sense has a limit of voltage dropout between converter's output and load terminals of 2-10% of voltage output.
 When not used connect + SENSE to +VOUT and –SENSE to –VOUT

OUT GOOD

The VOLTS GOOD TTL signal is used to indicate if the output voltage is within the calibrated tolerances (above 90%).
 TTL "1" - output is within the required tolerances.
 TTL "0" - output is not within the required tolerances.

Typical Connection

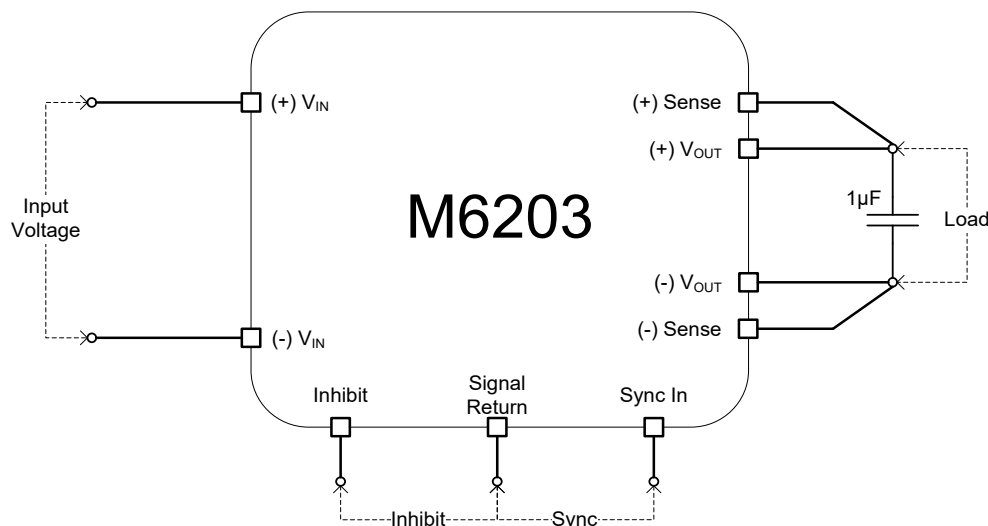

M6203 SERIES DC/DC POWER SUPPLY

Outline Drawing

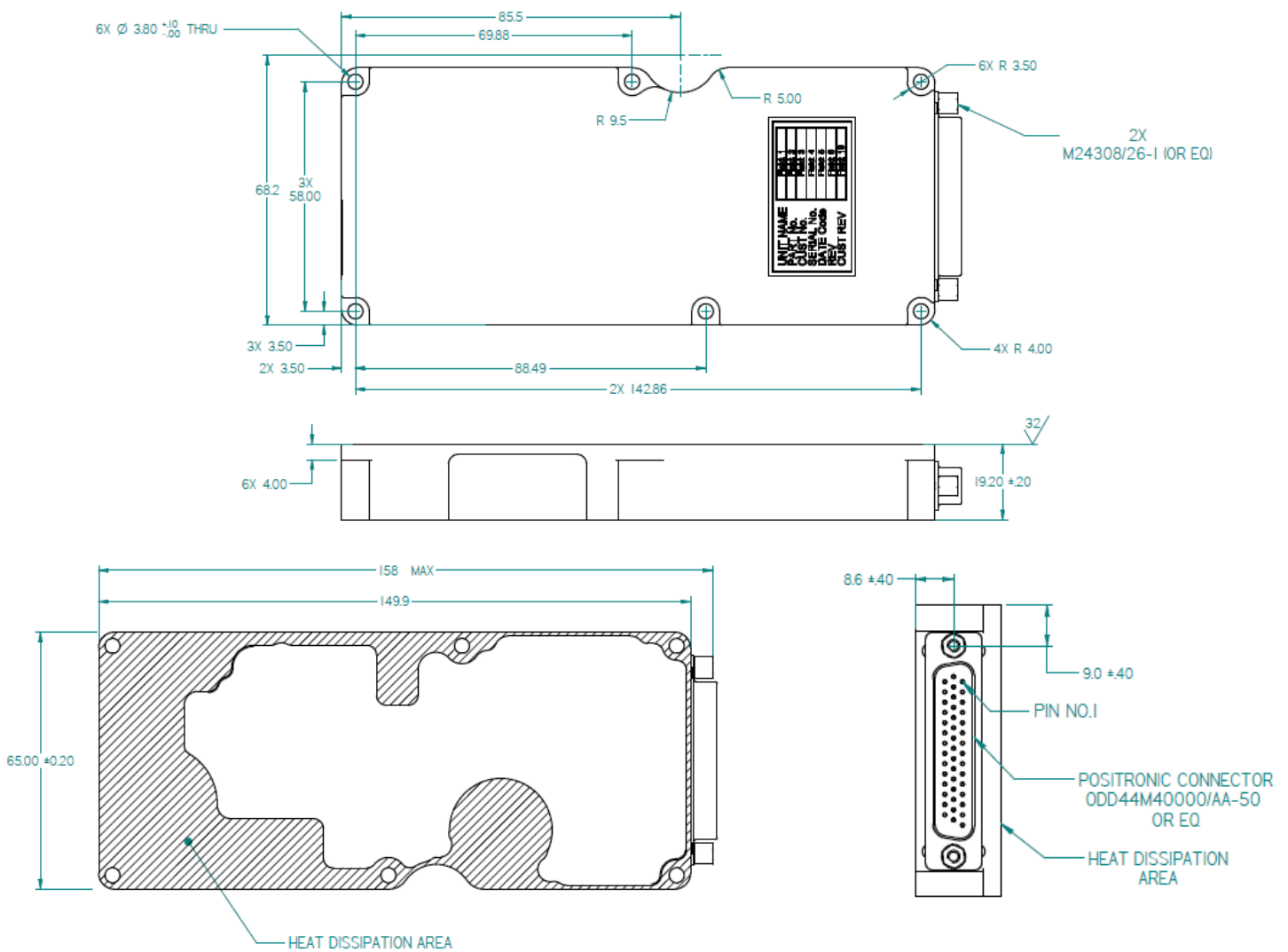

NOTES:

1. WORKMANSHIP SHALL BE MIL-STD-454, REQ. 9.
2. MTL. AL 6061-T651& AL 5052-H32.
3. CONVERSION COATING PER MIL-DTL-5541 LAST REV., TYPE I, CLASS 1A.
4. HEAT DISSIPATION AREA - 3680 mm².
5. Weight: Typical 360g

M6203 SERIES DC/DC POWER SUPPLY

Standard Configurations

Part Number	Input	Output		Special features
	Voltage range	Voltage	Current	
M6203-100	200 to 350 V _{DC}	5 V _{DC}	30 A	
M6203-101	200 to 350 V _{DC}	12 V _{DC}	30 A	
M6203-102	200 to 350 V _{DC}	15 V _{DC}	26 A	
M6203-103	200 to 350 V _{DC}	24 V _{DC}	16.5 A	
M6203-104	200 to 350 V _{DC}	28 V _{DC}	14.5 A	
M6203-105	200 to 350 V _{DC}	48 V _{DC}	8 A	

Note: Specifications are subject to change without prior notice by the manufacturer.