

M6204 SERIES

DC/DC POWER SUPPLY



PRODUCT HIGHLIGHTS

- **MINIATURE**
- **HIGH DENSITY**
- **HIGH EFFICIENCY**
- **SINGLE OUTPUT**
- **DC/DC POWER SUPPLY**
- **UP TO 400 W**

M6204 SERIES DC/DC POWER SUPPLY

Applications

Military (Airborne, ground-fix, shipboard), Ruggedized, Telecom, Industrial

Special Features

- Miniature size
- High efficiency
- Wide input range
- Input / Output isolation
- Remote sense
- External On/Off Inhibit
- Zero Voltage Switching Technology
- Fixed switching freq. (250 kHz)
- External synchronization capability
- EMI filters included
- Inrush circuit
- Indefinite short circuit protection with auto-recovery
- Over-voltage shutdown with auto-recovery
- Over temperature shutdown with auto-recovery

Electrical Specifications

DC Input

Voltage range: 220 to 380V_{DC}

Optional: 200 to 350V_{DC}

Please consult factory for details

Line/Load/Temp regulation

Up to $\pm 1\%$ (no load to full load, -55°C to $+85^{\circ}\text{C}$ and over input

voltage range).

Ripple and Noise

Less than 50 mV_{p-p}, typical (max. 1%) without external capacitance. When connected to system capacitance ripple drops significantly.

DC Output

Voltage range: 1.8 to 28V_{DC}

Current range: 0 to 50A

Power range: 0 to 400W

Optional:

Short time peak up to 500W

Please consult factory for details

Efficiency

Typical 88-90% - (nominal line, full load, room temperature)

Transient Over-and-undershoot

Output impedance at load change of 50% to 100% is 30 to 200m Ω (depending on output voltage).

Output returns to steady-state within 300 to 500 μs .

Isolation

Input to Output: 500V_{DC}

Input to Case: 500V_{DC}

Output to Case: 100V_{DC}

EMC

Designed to meet MIL-STD-461F*

CE101, CE102, CS101, CS114, CS115, CS116, RE101, RE102, RS101, RS103

Turn-on Transient

No Voltage over shoot during Power on.

*EMC compliance achieved when tested with 5 μH LISNs, shielded harness and static resistive load.

M6204 SERIES DC/DC POWER SUPPLY

Protections*

Input

- **Inrush Current Limiter**
Peak value of up to 5 times the maximum steady-state input current for inrush currents lasting over 50 μ s
- **Under-voltage Lock-out**
Unit protects itself (no damage) below 200V_{DC}**
- **Overvoltage protection**
Unit protects itself (no damage) above 380 V_{DC}**
Unit may be damaged if exposed to input voltages higher than 500V

Output

- **Electronic over-voltage protection**
Protects unit (no damage) 10%** above nominal voltage.
- **Passive transorb on outputs**
20%** above nominal voltage.
- **Current limiting**
Continuous protection (10-30% above maximum current) for unlimited time (Hiccup).

General

- **Over temperature protection** Shutdown at base plate temperature of +105°C*** Automatic recovery at base plate temperature lower than +95°C***

Environmental Conditions

Designed to Meet MIL-STD-810G

Temperature

Method 501.5 Procedures I & II
Method 502.5 Procedures I & II
Operating: -55°C to +85°C (baseplate)
Storage: -55°C to +125°C (ambient)

Altitude

Method 500.5
Procedures I & II
Up to 70000ft. Operational

Salt Fog:

Method 509.5

Humidity

Method 507.5
Up to 95% RH.

Vibration (Random)

Method 514.6
Random Vibration, Category 24, Fig 514.6E-1.

Shock

Method 516.6
30g, 11ms terminal peak saw-tooth (all directions)

Reliability

150,000 hours, calculated MIL-STD-217F Notice 2 at +85°C base plate, Ground fixed.

Environmental Stress Screening (ESS)

Including random vibration and thermal cycles is also available. **Please consult factory for details.**

* Thresholds and protections can be modified / removed – please consult factory.

** Standard tolerance is $\pm 5\%$

*** Standard tolerance is $\pm 5^\circ\text{C}$

Functions and Signals

INHIBIT signal

The **INHIBIT** signal is used to turn the power supply ON and OFF.

TTL “1” or OPEN – will turn the power supply ON (For normal operation leave the signal not connected).

TTL “0” or short– will turn the power supply OFF. This signal is referenced to the **SIGNAL RTN** pin.

SYNC IN signal

The **SYNC IN** signal is used to allow the power supply frequency to sync with the system frequency. The system frequency should be $250 \text{ kHz} \pm 10 \text{ kHz}$.

When not connected the power supply will work at $250 \text{ kHz} \pm 10 \text{ kHz}$. This signal is referenced to the **SIGNAL RTN** pin.

SIGNAL RTN

The **SIGNAL RTN** pin is used as a return path for **SYNC IN** and **INHIBIT** signals. This pin is referenced to the **VIN RTN** pin.

SENSE 1

The **SENSE 1** is used to achieve accurate load regulation at output #1's load terminals. This is done by connecting the pins directly to the load terminals. The remote sense correction function is limited to voltage drop between converter's output and load terminals of 2% to 5%, or up to 0.5V, the least of the two.

When not used, connect **SENSE 1** to **OUT 1** and **SENSE 1 RTN** to **OUT 1 RTN**. These pins can be tied internally if not required, to avoid adding this external connection – *consult factory*.

M6204 SERIES DC/DC POWER SUPPLY

Pin Assignment

Connector type: M24308/24-40F or eq.

Mates with: M24308/2-4F or eq.

Pin No.	Pin Function	Color	Pin No.	Pin Function	Color	Pin No.	Pin Function	Color
1	CHASSIS	Green	14	INHIBIT	Blue	27	OUT RTN (-)	Black
2	OUT (+)	Red	15	N.C.		28	OUT RTN (-)	Black
3	OUT (+)	Red	16	VIN (+)	Brown	29	OUT RTN (-)	Black
4	OUT (+)	Red	17	N.C.		30	OUT RTN (-)	Black
5	OUT (+)	Red	18	VIN RTN (-)	Blue	31	SYNC	Grey
6	OUT (+)	Red	19	VIN RTN (-)	Blue	32	N.C.	
7	OUT RTN (-)	Black	20	OUT (+)	Red	33	N.C.	
8	OUT RTN (-)	Black	21	OUT (+)	Red	34	VIN (+)	Brown
9	OUT RTN (-)	Black	22	OUT (+)	Red	35	VIN (+)	Brown
10	OUT RTN (-)	Black	23	OUT (+)	Red	36	N.C.	
11	SENSE RTN (-)	White	24	OUT (+)	Red	37	VIN RTN (-)	Blue
12	SENSE (+)	White	25	OUT RTN (-)	Black			
13	SIGNAL RTN	Blue	26	OUT RTN (-)	Black			

Note: All output parallel pins should be connected together for best performance.

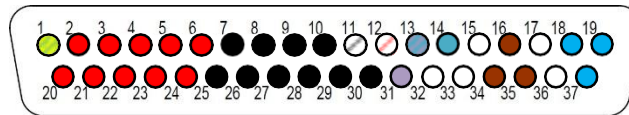

Typical Connection Diagram

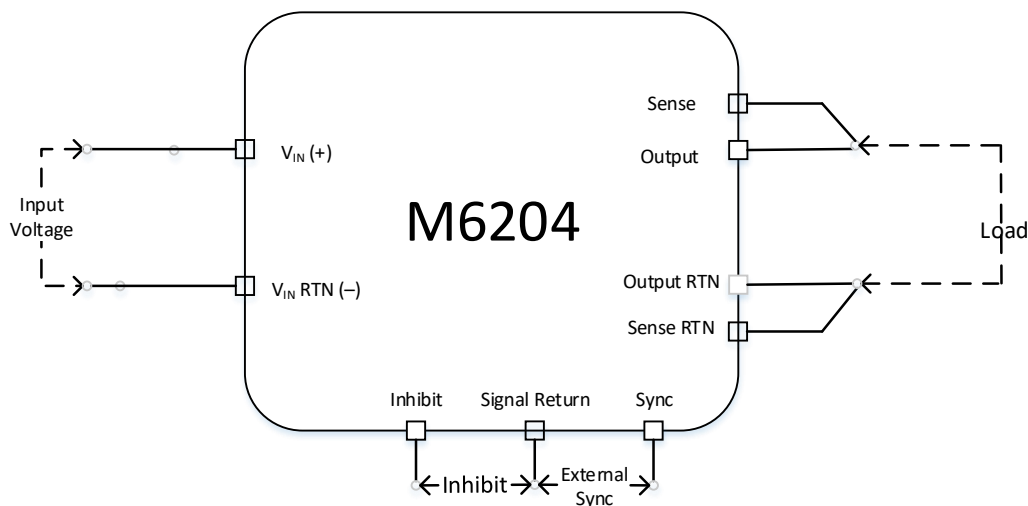

M6204 SERIES DC/DC POWER SUPPLY

Outline Drawing

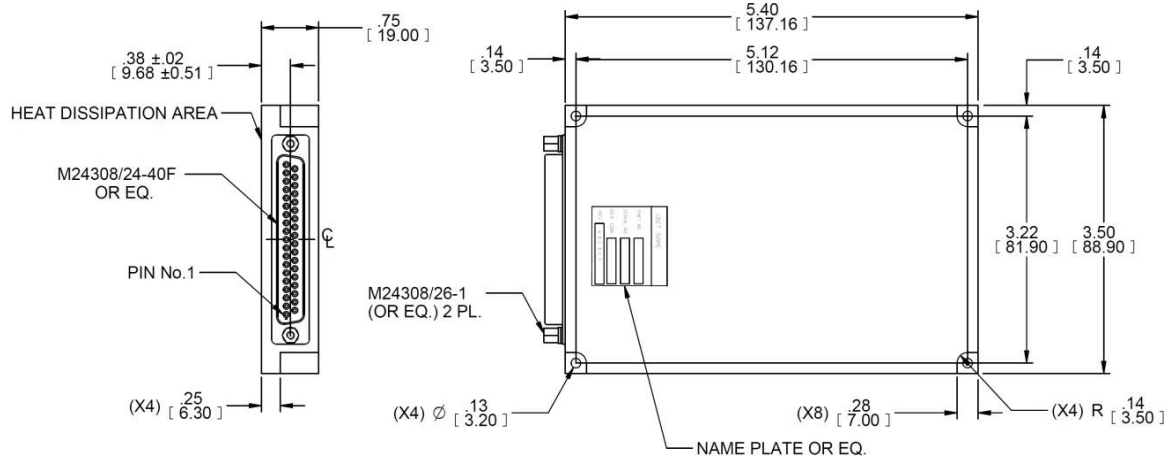

Heat Dissipation Surface

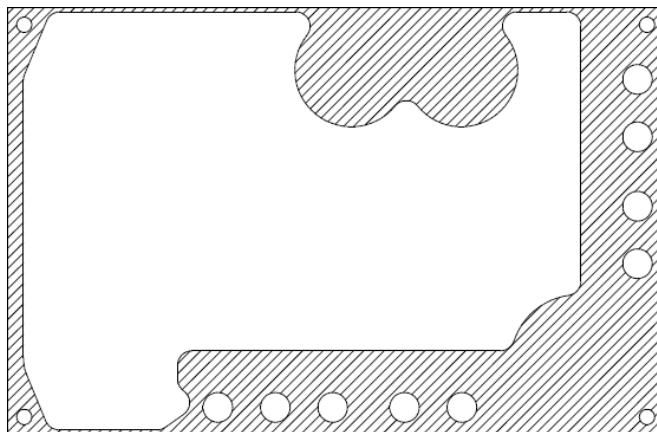

Dissipation Area
6.63 in²
(4278 mm²)

Notes

1. Dimensions are in inches [mm]
2. Tolerance is:
.XX ± 0.01 in
.XXX ± 0.005 in
3. Weight: Approx. 14.40 oz (408 g)

Note: Specifications are subject to change without prior notice by the manufacturer.