

# M7429 SERIES

## SINGLE-OUTPUT, 300W DC TO DC BASEPLATE COOLED POWER SUPPLY , SEAL UNIT

The M7429 is a series of mechanically robust, base-plate cooled, high performance, power supplies, designed for Ground Mobile (MIL-STD-1275E), Airborne (MIL-STD-704) and other Hi-Reliability applications where 28VDC has to be converted to a tightly regulated, filtered and protected DC output.



### STANDARD CONFIGURATIONS

**Option 1:** for MIL-STD-704F input:

Part Number	Input	Output		Special features
	Voltage range	Voltage	Current	
M7429-100	18 to 50 V <sub>DC</sub>	5 V <sub>DC</sub>	20 A	
M7429-101	18 to 50 V <sub>DC</sub>	12 V <sub>DC</sub>	20 A	
M7429-102	18 to 50 V <sub>DC</sub>	15 V <sub>DC</sub>	20 A	
M7429-103	18 to 50 V <sub>DC</sub>	24 V <sub>DC</sub>	12.5 A	
M7429-104	18 to 50 V <sub>DC</sub>	28 V <sub>DC</sub>	10.7 A	
M7429-105	18 to 50 V <sub>DC</sub>	48 V <sub>DC</sub>	6.2 A	
M7429-800	18 to 50 V <sub>DC</sub>	5 V <sub>DC</sub>	20 A	*This Product is REACH Compliant *The aluminum parts comprising this converter are chromate conversion coated per MIL-DTL-5541F, Type II CLASS 1A or eq.
M7429-801	18 to 50 V <sub>DC</sub>	12 V <sub>DC</sub>	20 A	
M7429-802	18 to 50 V <sub>DC</sub>	15 V <sub>DC</sub>	20 A	
M7429-803	18 to 50 V <sub>DC</sub>	24 V <sub>DC</sub>	12.5 A	
M7429-804	18 to 50 V <sub>DC</sub>	28 V <sub>DC</sub>	10.7 A	
M7429-805	18 to 50 V <sub>DC</sub>	48 V <sub>DC</sub>	6.2 A	

**Option 2\*:** for MIL-STD-1275E input:

Part Number	Input	Output		Special features
	Voltage range	Voltage	Current	
M7429-110	12 to 100 V <sub>DC</sub>	5 V <sub>DC</sub>	20 A	
M7429-111	12 to 100 V <sub>DC</sub>	12 V <sub>DC</sub>	20 A	
M7429-112	12 to 100 V <sub>DC</sub>	15 V <sub>DC</sub>	20 A	
M7429-113	12 to 100 V <sub>DC</sub>	24 V <sub>DC</sub>	12.5 A	
M7429-114	12 to 100 V <sub>DC</sub>	28 V <sub>DC</sub>	10.7 A	
M7429-115	12 to 100 V <sub>DC</sub>	48 V <sub>DC</sub>	6.2 A	
M7429-810	12 to 100 V <sub>DC</sub>	5 V <sub>DC</sub>	20 A	*This Product is REACH Compliant *The aluminum parts comprising this converter are chromate conversion coated per MIL-DTL-5541F, Type II CLASS 1A or eq.
M7429-811	12 to 100 V <sub>DC</sub>	12 V <sub>DC</sub>	20 A	
M7429-812	12 to 100 V <sub>DC</sub>	15 V <sub>DC</sub>	20 A	
M7429-813	12 to 100 V <sub>DC</sub>	24 V <sub>DC</sub>	12.5 A	
M7429-814	12 to 100 V <sub>DC</sub>	28 V <sub>DC</sub>	10.7 A	
M7429-815	12 to 100 V <sub>DC</sub>	48 V <sub>DC</sub>	6.2 A	

\*For input voltage below 18V there is an output power limitation:

V <sub>in</sub>	P <sub>out</sub> [W]	% from max
18V	300W	100%
16V	240W	80%
14V	210W	70%
12V	180W	60%

### THE MAIN FEATURES OF THE M7429 ARE:

- DC/DC Single outputs power supply up to 300W
- Two input voltage range options:
  - Option 1: 18-50V IAW MIL-STD-704F
  - Option 2: 12-100V IAW MIL-STD-1275E
- High efficiency – up to 87% (depending on output voltage).
- Full galvanic isolation between Input, Chassis and Outputs
- External Inhibit (On/Off) .
- External synchronization.
- Fixed switching freq. (250 kHz)
- EMI filters included
- Remote sense compensation
- Indefinite short circuit protection with auto-recovery
- Over-voltage protection
- Over temperature shutdown with auto-recovery
- High density
- Conduction cooled via the baseplate
- IP 67 Sealing

**SPECIFICATIONS:**

<b>DC Input</b>	<b><i>Voltage Range</i></b>	<b>Standard Voltage Range:</b> 18 to 50 VDC IAW MIL-STD-704F  <b>Extended input range option:</b> 12 to 100 V <sub>DC</sub> IAW MIL-STD-1275E
	<b><i>Isolation</i></b>	Input to Output: 200 VDC Input to Case: 200 VDC
	<b>Input Reverse Polarity</b>	Protection for unlimited time
	<b>Under-Voltage Lock-Out</b>	The unit shuts down below 15V ± 1V*. Resumes operation at 17V ± 1V*. Min. hysteresis 2V*. *Estimated values. <b>For 12-100V input range option:</b> Under Vin = 11V ± 1V.
	<b>Over-Voltage Lock-Out</b>	<b>Over Voltage Protection for 18-50V input:</b> The unit shuts down above 55V ± 4V.  <b>Over Voltage Protection for 12-100V input:</b> The unit shuts down above 105 ± 2V.
<b>DC Output</b>	<b><i>Rating</i></b>	See table on page 9
	<b><i>Voltage Regulation</i></b>	Better than or equal to ±1% (low to high line voltage, no load to full load, –55 °C to +80 °C at baseplate).
	<b><i>Remote Sense</i></b>	The SENSE is used to achieve accurate load regulations at load terminals (this is done by connecting the pins directly to the load's terminals). For output voltage above 8V, the use of remote sense has a max limit of 0.25V voltage dropout between converter's output and load terminals. For output voltage below 8V, the use of remote sense has a max limit of 0.5V voltage dropout between converter's output and load terminals. When not used connect SENSE 1 to OUT 1 and SENSE 1 RTN to OUT 1 RTN.
	<b><i>Ripple</i></b>	Less than 50 mVp-p, typical (max. 1% of output voltage)
	<b><i>Isolation</i></b>	Output to Case: 100 VDC

## W7429 Series– DC/DC Power Supply

	<b>Overvoltage Protection</b>	<ul style="list-style-type: none"> <li>• <b>Active Over-Voltage Protection:</b> The secondary control circuit takes the over if output voltage exceeds 110% ± 5% of nominal voltage. Beyond this, output voltage clamps.</li> <li>• <b>Passive Over-Voltage Protection:</b> Zener diode installed on output terminals, selected at 120% ± 10% of nominal voltage.</li> </ul>															
	<b>Efficiency</b>	<p>Typical: 88% - 90%            Extended input range: 83% - 86%            (28V<sub>DC</sub> output, nominal input, full load, room temperature)</p>															
	<b>Current Limit &amp; Overload</b>	<p>Output voltage turns off and on periodically with low duty cycle (hiccup) to protect system conductors and converter from short circuit</p>															
	<b>Over Temp. Protection</b>	<p>Output shuts down if base plate temperature exceeds +100°C ± 5°C. Automatic recovery when baseplate temperature returns to below +90°C ± 5°C.</p>															
	<b>Output Power Derating</b>	<p>For input voltages below 18V there is an output power limitation:</p> <table border="1" data-bbox="523 1084 1134 1285"> <thead> <tr> <th>V<sub>in</sub></th> <th>P<sub>out</sub> [W]</th> <th>% from max</th> </tr> </thead> <tbody> <tr> <td>18V</td> <td>300W</td> <td>100%</td> </tr> <tr> <td>16V</td> <td>240W</td> <td>80%</td> </tr> <tr> <td>14V</td> <td>210W</td> <td>70%</td> </tr> <tr> <td>12V</td> <td>180W</td> <td>60%</td> </tr> </tbody> </table>	V <sub>in</sub>	P <sub>out</sub> [W]	% from max	18V	300W	100%	16V	240W	80%	14V	210W	70%	12V	180W	60%
V <sub>in</sub>	P <sub>out</sub> [W]	% from max															
18V	300W	100%															
16V	240W	80%															
14V	210W	70%															
12V	180W	60%															

Specifications (Cont.):

<b>Control &amp; Indication</b>	<b><i>INHIBIT Signal Optional</i></b>	<p>The <b>INHIBIT</b> signal is used to turn the power supply ON and OFF. To turn the power supply OFF, apply a TTL “0” signal or SHORT to <b>SIGNAL RTN</b>.</p> <p>To turn the power supply ON, apply a TTL “1” signal or leave this pin OPEN.</p> <p>If not used (always ON), leave this pin OPEN.</p> <p>This signal is referenced to <b>SIGNAL RTN</b>.</p>
	<b><i>SYNC IN Optional</i></b>	<p>The <b>SYNC IN</b> signal is used to allow the power supply frequency to sync with the system frequency.</p> <p>The system frequency should be 250 kHz ± 10 kHz.</p> <p>When not connected the power supply will work at 250 kHz ± 10 kHz.</p> <p>This signal is referenced to <b>SIGNAL RTN</b></p>
	<b><i>SIGNAL RTN</i></b>	<p>INHIBIT and SYNC signals are referenced to this pin.</p> <p>This pin is referenced to IN RTN.</p>
<b>Environment Designed to meet MIL-STD-810F</b>	<b><i>Temperature</i></b>	<p>Methods 501.4 &amp; 502.4</p> <p>Operating: –55 °C to +80 °C (at baseplate)</p> <p>Storage: –55 °C to +125 °C (ambient)</p>
	<b><i>Humidity</i></b>	<p>Method 507.4</p> <p>Up to 95% RH</p>
	<b><i>Salt-fog</i></b>	<p>Method 509.4</p>
	<b><i>Altitude</i></b>	<p>Method 500.4</p> <p>Procedures I – Storage/Air transport: up to 70,000 ft. (non-operational)</p> <p>Procedure II – Operation/Air Carriage: up to 70,000 ft. (operational)</p>
	<b><i>Mechanical Shock</i></b>	<p>Method 516.5</p> <p>Procedure I</p> <p>50 g / 11 ms terminal peak half-sine shock pulse</p>
	<b><i>Vibration</i></b>	<p>Method 514.5</p> <p>Procedure I</p> <p>14.76 g<sub>rms</sub> 20-2000 Hz for 500 seconds at each of 3 perpendicular axes.</p>
	<b><i>Fungus</i></b>	<p>Does not support fungus growth, in accordance with the guidelines of MIL-STD-454, Requirement 4-</p>

		<b>M7429 Series– DC/DC Power Supply</b>
<b>EMI</b>	<i>MIL-STD-461F</i>	<b>Note 1</b> *EMI Compliance achieved with 5µH LISN, shielded harness and static resistive load. (Optional: 50 µH – Please consult factory)
<b>Reliability</b>	150,000 hours, calculated per MIL-HDBK-217F Notice 2 at +85 °C baseplate, Ground Fix conditions.	
<b>Cooling Requirements</b>	The M7429 is a baseplate cooled unit. The base of the M7429 should be thermally attached to a suitable heatsink that maintains it below +85 °C.	
<b>Sealing</b>	IP 67	
<b>Weight</b>	Approx. 2.9 lb	
<b>Connectors</b>	<b>Connector type:</b> J1 - INPUT CONNECTOR TV07TZCI13-35P (Amphenol P/N) OR EQ. J2 - OUTPUT CONNECTOR TV07TZCI13-98S (Amphenol P/N) OR EQ. <b>Mates with:</b> J1 - D38999/26WC35SN J2 - D38999/26WC98PN	

**Note 1:**

Standard	Details requirements	
MIL-STD-810G		
EMC / EMI (MIL-STD-461G)	CE102	
	CS101	Curve#2
	CS114	10KHz – 2MHz, curve#3 2MHz – 200MHz, curve#4
	CS115	
	CS116	
	RE102	Ground levels, RE102-4
	RS103	50V / M
	CS118	Level4, 15kV
	ESD	

TYPICAL CONNECTION DIAGRAM FOR M7429 SERIES

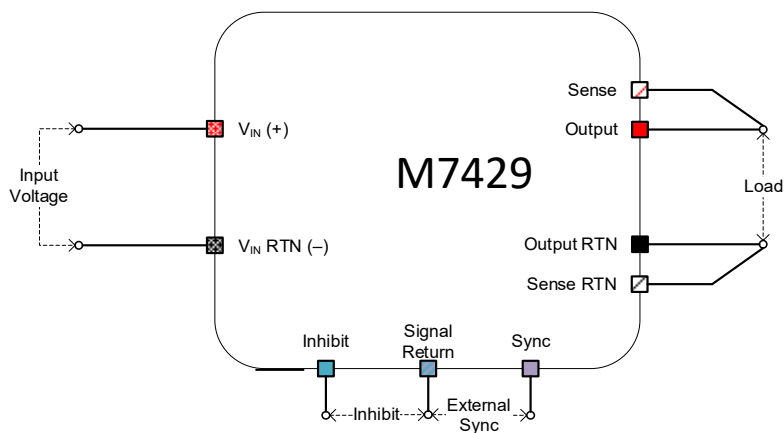

TEST RESULTS FOR M7429 SERIES

Plot 5.10: CE102 test results in 10 kHz -10MHz range, +28 VDC

Display line is Limit

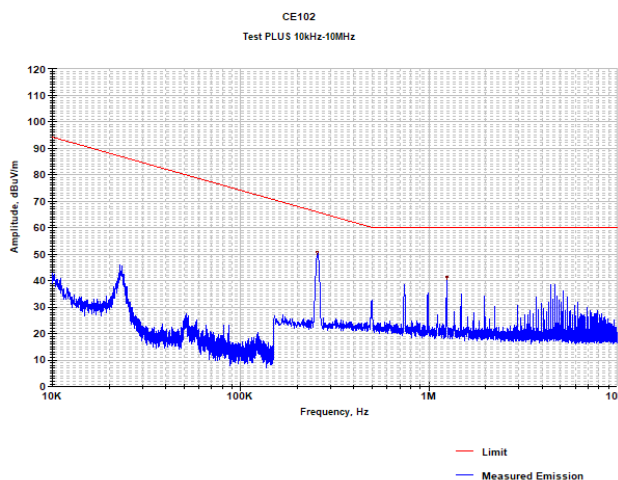

Plot 5.14: CE102 test results in 10 kHz – 10MHz range, -28 VDC

Display line is Limit

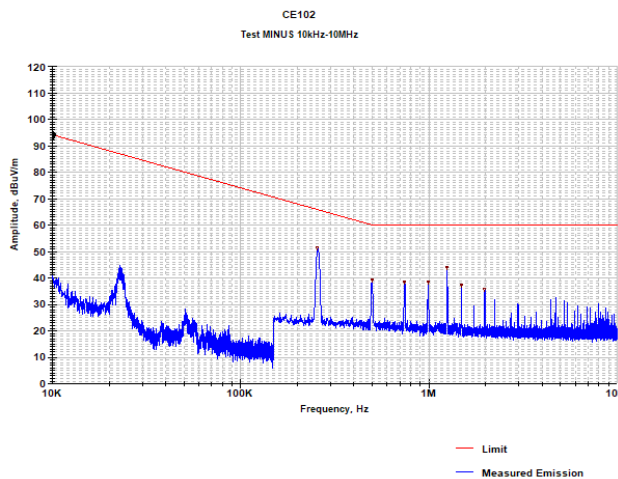

Plot 11.7: RE102 test results within 2MHz -30 MHz, vertical polarization

Display line is Limit

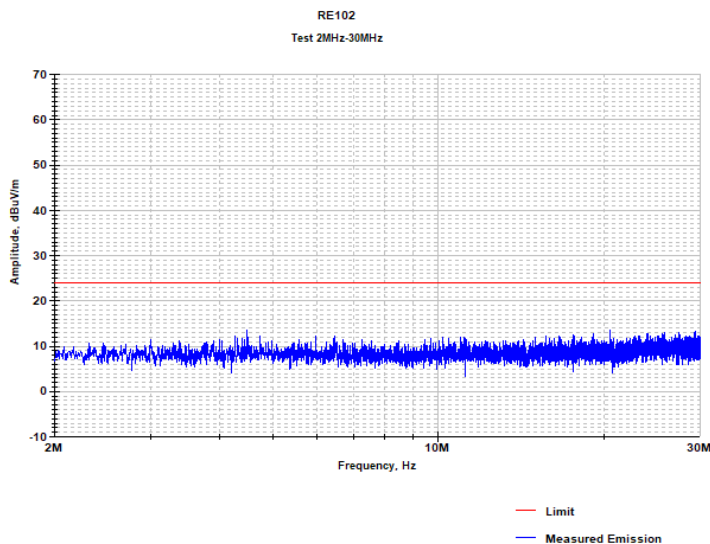

Plot 11.14: RE102 test results within 30 – 200 MHz, vertical polarization

Display line is Limit

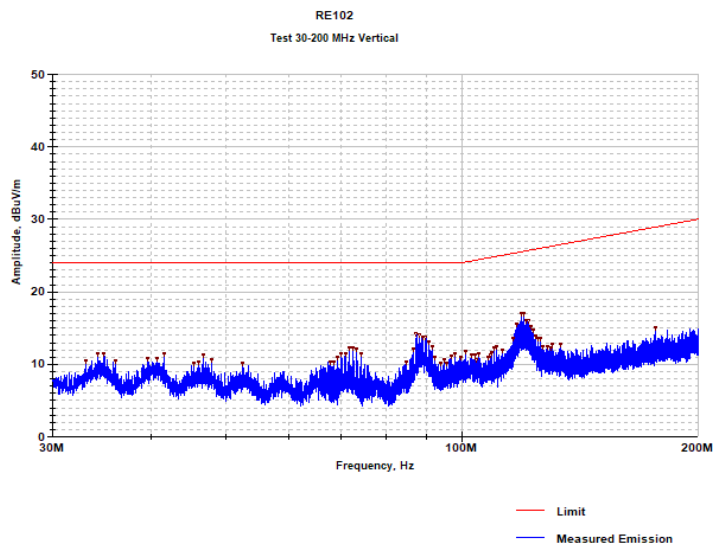

Plot 11.15: RE102 test results within 30 – 200 MHz, horizontal polarization

Display line is Limit

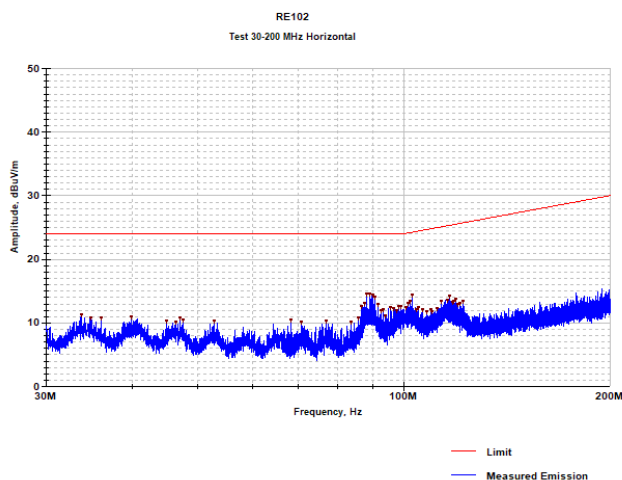

Plot 11.19: RE102 test results within 200 – 1000 MHz, vertical polarization

Display line is Limit

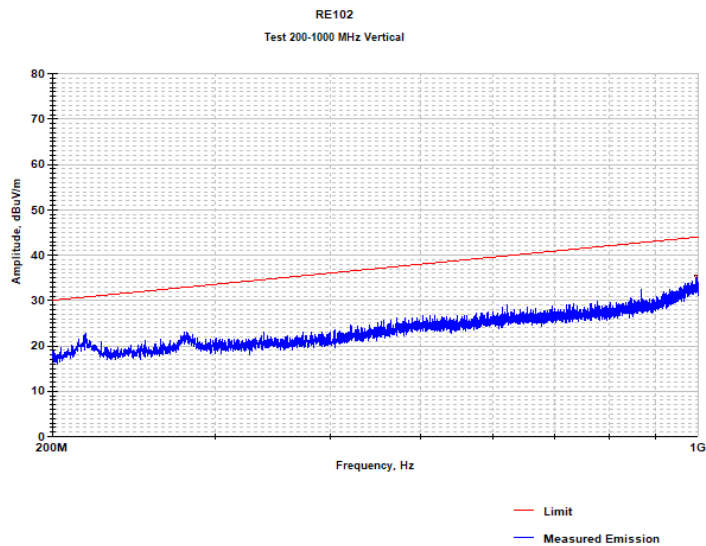

Plot 11.21: RE102 test results within 200 – 1000 MHz, horizontal polarization

Display line is Limit

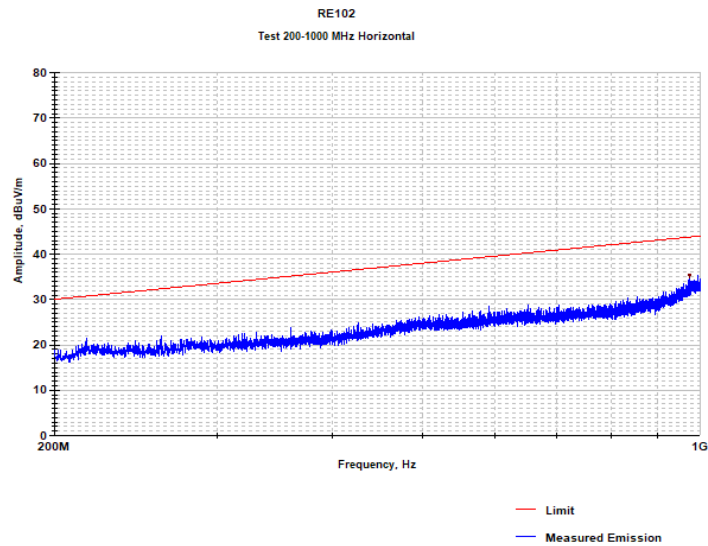

Plot 11.25: RE102 test results within 1000 – 18000 MHz, vertical polarization

Display line is Limit

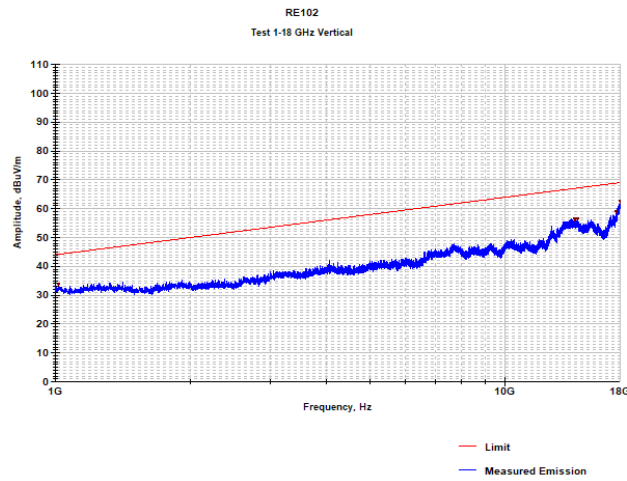

Plot 11.25: RE102 test results within 1000 – 18000 MHz, horizontal polarization

Display line is Limit

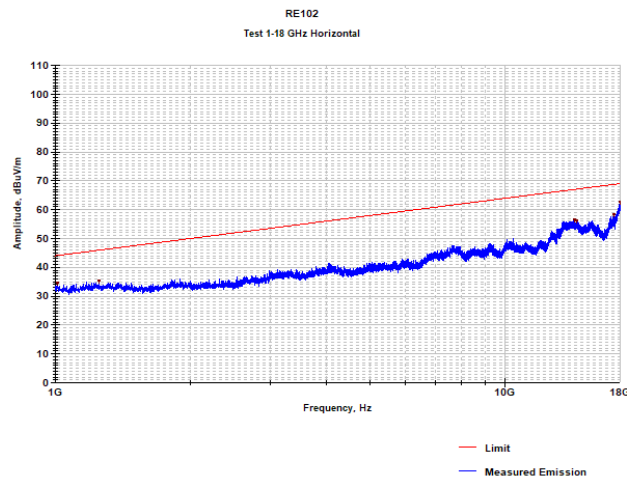

Plot 11.25: RE102 test results within 1000 – 18000 MHz, HORIZONTAL polarization, 25 cm from EUT

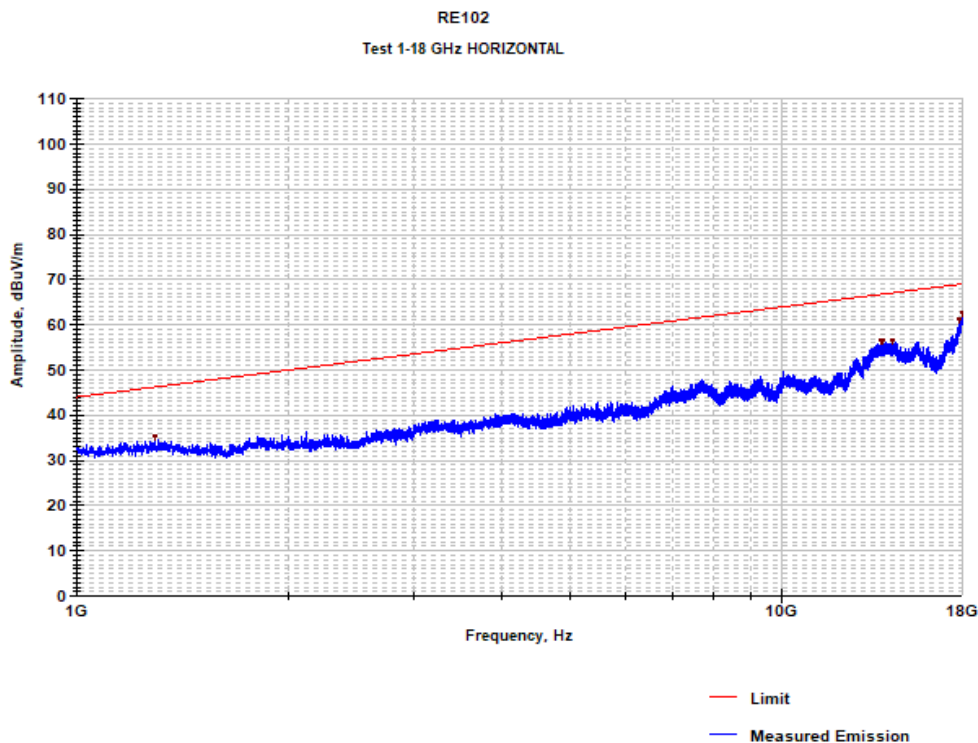

Frequency (MHz)	Measured Emission (dBuV/m)	Limit (dBuV/m)	Delta (dB)
1290.000	35.4	46.2	-10.8
13828.000	56.5	66.7	-10.2
13866.000	56.3	66.7	-10.5
14304.000	56.3	67.0	-10.7
17837.000	61.1	68.9	-7.8
17998.000	62.5	69.0	-6.5

**PIN ASSIGNMENT:**

**Connector type:** J1 TVS07BCI13-35P (Amphenol P/N) OR EQ.

**Mates with:** D38999/26WC35SN

**J1 INPUT CONNECTOR**

Pin #	Function	Pin #	Function
1	INPUT	12	INPUT RTN
2	INPUT	13	INPUT RTN
3	INPUT	14	INPUT RTN
4	INPUT	15	INPUT
5	INPUT	16	INPUT
6	INPUT	17	INPUT
7	INHIBIT	18	SIGNAL RTN
8	SYNC	19	INPUT RTN
9	INPUT RTN	20	INPUT RTN
10	INPUT RTN	21	INPUT RTN
11	INPUT RTN	22	INPUT RTN

**Connector type:** J2 TVS07BCI13-98S (Amphenol P/N) OR EQ.

**Mates with:** D38999/26WC98PN

**J2 OUTPUT CONNECTOR**

Pin #	Function
A	OUTPUT RTN
B	OUTPUT RTN
C	OUTPUT RTN
D	-SENSE
E	+SENSE
F	OUTPUT
G	OUTPUT
H	OUTPUT
J	OUTPUT RTN
K	OUTPUT

Note: All pins with identical function/designation should be connected together for optimal performance.

**OUTLINE DRAWINGS FOR REACH COMPLIANT UNITS:**

*For detailed dimensions and tolerances see Drawing: M7429813*

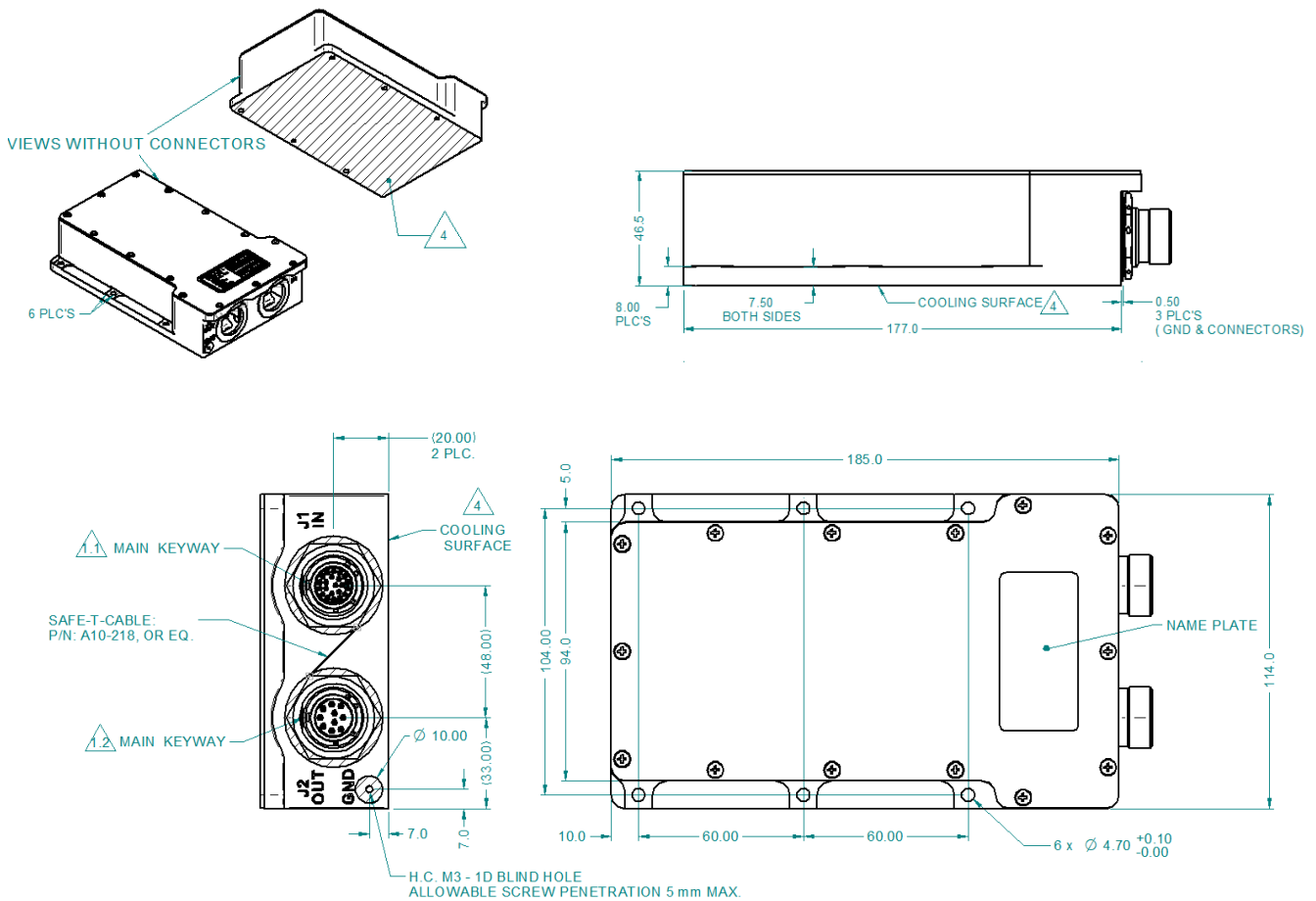

**NOTES :**

**1. CONNECTORS LIST:**

- 1.1. J1 - INPUT CONNECTOR TVS07BCI13-35P (Amphenol P/N) OR EQ.
- 1.2. J2 - OUTPUT CONNECTOR TVS07BCI13-98S (Amphenol P/N) OR EQ.

**2. MTL: AL 6061-T651, AL 5052-H32,**

**3. FINISH:**

- 3.1. CHROMATE CONVERSION COATING PER MIL -DTL-5541, LAST REVISION, TYPE II, CLASS 1A, CLEAR.

**4. COOLING: HEAT DISSIPATION AREA- 20,063 [mm<sup>2</sup>].**

**5. WORKMANSHIP SHALL BE MIL-STD-454, REQ. 9**

**6. ENGRAVING:**

- 6.1. CHARACTER HEIGHT : 4.0 MM.
- 6.2. CHARACTER DEPTH : 0.5 MM.
- 6.3. CHARACTER ARE CENTRALLY LOCATED,
- 6.4. FILL ENGRAVING WITH BLACK LUSTERLESS EPOXY PAINT COLOR PER FED-STD 595 NO : 37038.

**7. APPROX. WEIGHT: 1.3 K.G.**

*Note: Specifications are subject to change without prior notice by the manufacturer.*