

# M814 SERIES

## DC/DC POWER SUPPLY



### PRODUCT HIGHLIGHTS

- **MINIATURE, HIGH DENSITY**
- **EIGHT OUTPUTS**
- **UP TO 145 W**
- **DC/DC POWER SUPPLY**

### Applications

Military (airborne, mobile, shipboard), Ruggedized, Telecom, Industrial Power Supply

### Special Features

- Miniature size
- High efficiency
- Wide input range
- Input / Output isolation
- Outputs groups isolation
- Fixed switching frequency (~250 kHz)
- External synchronization capability
- Remote inhibit
- EMI filters included
- Non-latching protections:
  - Overload / short-circuit protection
  - Input under/over-voltage lockout
  - Over temperature shutdown

### Environmental Conditions

Meets or exceeds MIL-STD-810G

Temperature:

Operating -55 °C to +85 °C (at baseplate)

Storage -55 °C to +125 °C

### Reliability

150,000 hours, calculated IAW MIL-HDBK-217F Notice 2 at +85°C baseplate, Ground Fixed conditions.

### Electrical Specifications

#### DC INPUT

Voltage range: 18 to 70 V<sub>DC</sub>

Transient protection: protected against abnormal surge IAW MIL-STD-1275A (100 V / 50 ms) and MIL-STD-704A (80 V / 0.1 s)

Efficiency: Up to 80%

EMC: Designed to meet MIL-STD-461F\*  
CE101, CE102, CS101, CS114, CS115, CS116, RE101, RE102, RS101, RS103

Isolation:

Input to Output: 200 V<sub>DC</sub>

Input to Case: S200 V<sub>DC</sub>

#### DC OUTPUTS

Voltage regulation:

≤ ±1% (low to high line voltage, no load to full load, -55 °C to +85 °C)

Ripple and Noise: 50 mV<sub>p-p</sub>, typ. (max. 1%)

Overcurrent protection:

current limit (CC) beyond threshold.

Over voltage protection: Passive protection.

Over temperature protection:

Shutdown if baseplate temperature exceeds +105 °C ± 5 °C; Automatic recovery upon baseplate cooldown to below +95 °C ± 5 °C.

Isolation:

**Output and Case: 100 V<sub>DC</sub>**

\*EMC compliance achieved when tested with 5 µH LISNs , shielded harness and static resistive load.

# M814 SERIES DC/DC POWER SUPPLY

## Operational Block Diagram

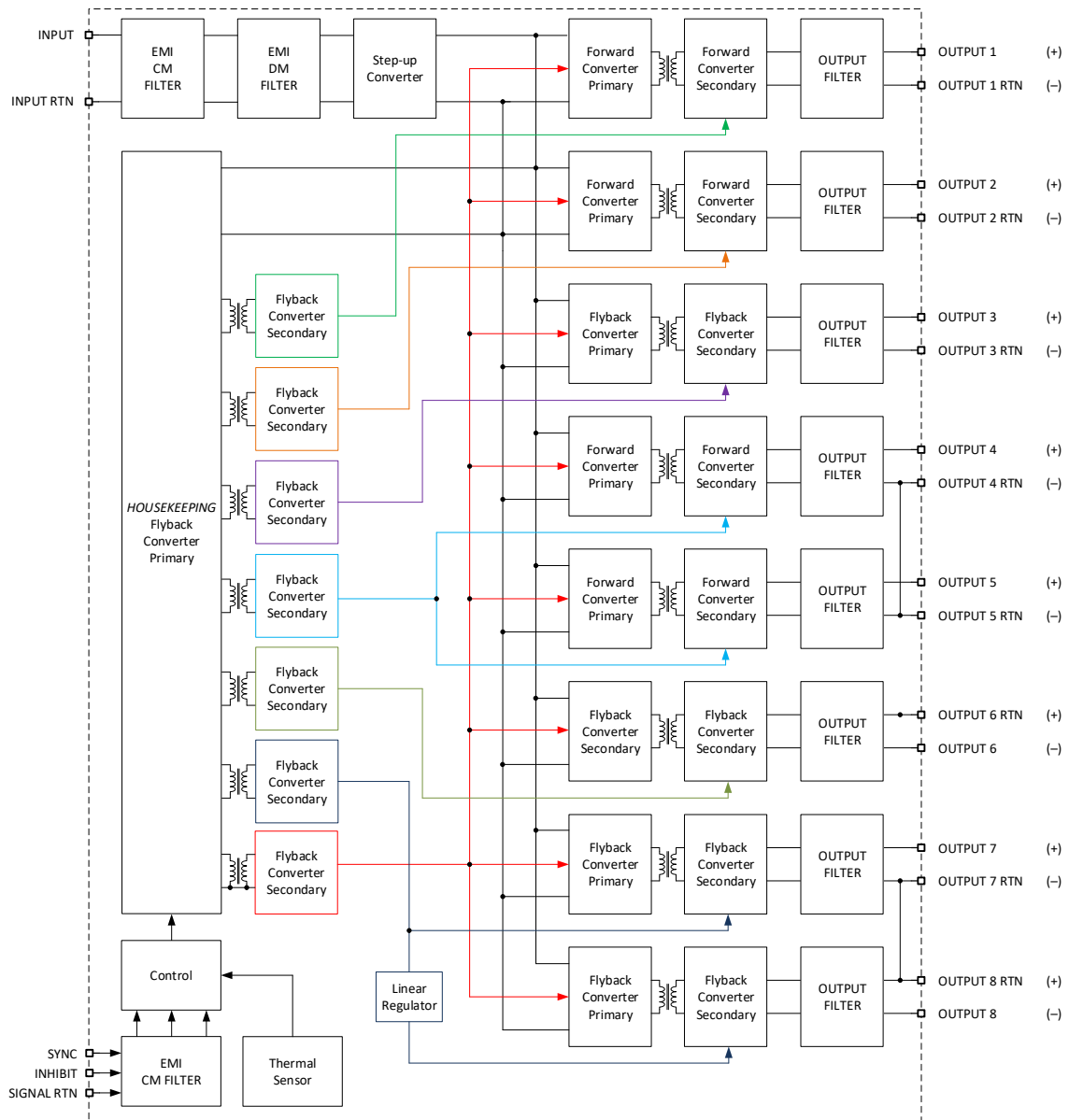

## M814 SERIES DC/DC POWER SUPPLY

### Outputs Configuration Range

Output #	Voltage Range	Current Range	Power Range
1	2.5 to 70 V <sub>DC</sub>	0 to 10 A	0 to 45 W
2	2.5 to 70 V <sub>DC</sub>	0 to 6 A	0 to 45 W
3	2.5 to 28 V <sub>DC</sub>	0 to 2 A	0 to 15 W
4	2.5 to 28 V <sub>DC</sub>	0 to 2 A	0 to 35 W
5	2.5 to 28 V <sub>DC</sub>	0 to 2 A	0 to 20 W
6	2.5 to 28 V <sub>DC</sub>	0 to 2 A	0 to 12 W
7	2.5 to 28 V <sub>DC</sub>	0 to 1 A	0 to 15 W
8	-2.5 to -28 V <sub>DC</sub>	0 to 1 A	0 to 15 W
<b>Total</b>			0 to 145 W

### Outputs Isolation (Ground RTN groups)

- All outputs are isolated from the input.
- Outputs are separated into the following six galvanically isolated groups:
  - Group A: Output #1
  - Group B: Output #2
  - Group C: Output #3
  - Group D: Outputs #4 and #5
  - Group E: Output #6
  - Group F: Outputs #7 and #8

## M814 SERIES DC/DC POWER SUPPLY

### Pin Assignment

**Connector type:** M55302/61-A40 or eq.

**Mating connector type:** M55302/62-A40M (solder cup termination) or M55302/66-40M (#22 AWG crimp termination) or eq.

Pin #	Function	P		Pin #	Function	P		Pin #	Function	P	
1	INPUT		●	15	OUT 2	+	●	29	OUT 4,5 RTN	-	●
2	INPUT		●	16	OUT 2 RTN	-	○	30	OUT 1 RTN	-	○
3	INPUT		●	17	OUT 8	-	●	31	OUT 1 RTN	-	○
4	INPUT RTN		●	18	OUT 7,8 RTN		●	32	OUT 1	+	●
5	INPUT RTN		●	19	OUT 7	+	●	33	OUT 1	+	●
6	OUT 6 RTN		○	20	OUT 3 RTN	-	○	34	OUT 2	+	●
7	OUT 6		●	21	INPUT	+	●	35	OUT 2 RTN	-	○
8	OUT 5	C	●	22	INPUT	+	●	36	CHASSIS		●
9	OUT 4,5 RTN		●	23	INPUT RTN	-	●	37	OUT 7,8 RTN		●
10	OUT 4		●	24	INPUT RTN	-	●	38	OUT 3	+	●
11	OUT 1 RTN		○	25	INPUT RTN	-	●	39	OUT 3	+	●
12	OUT 1 RTN		○	26	INHIBIT	+	●	40	OUT 3 RTN	-	○
13	OUT 1		●	27	SIGNAL RTN	-	●				
14	OUT 1		●	28	SYNC	+	●				

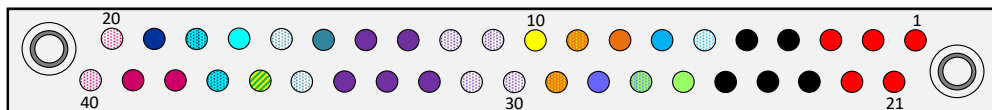

### Signals Description

**INHIBIT** (pin 26)

## M814 SERIES DC/DC POWER SUPPLY

The **INHIBIT** signal is used to turn the power supply ON and OFF.

TTL "1" or OPEN – Power supply active (output turned on).

TTL "0" or SHORT to **SIGNAL RTN** – Power supply inhibited (output turned off).

If this function is not required, leave this pin unconnected.

This signal is referenced to **SIGNAL RTN** (pin 27)

### **SYNC** (pin 28)

The **SYNC** signal is used to synchronize the power supply's switching frequency to system's clock.

If this function is not required, leave this pin unconnected - the power supply will use its internal clock.

External clock frequency can be between 240 kHz to 260 kHz, with duty cycle of 40% to 60%.

Valid clock voltage level is between 5 to 12 V.

This signal is referenced to **SIGNAL RTN** (pin 27)

### **SIGNAL RTN** (pin 27)

Both **INHIBIT** and **SYNC** signals are referenced to this pin.

This pin is referenced to **INPUT RTN** (pins 4, 5, 23, 24 and 25).

## Outline Drawing

**M814 SERIES DC/DC POWER SUPPLY**

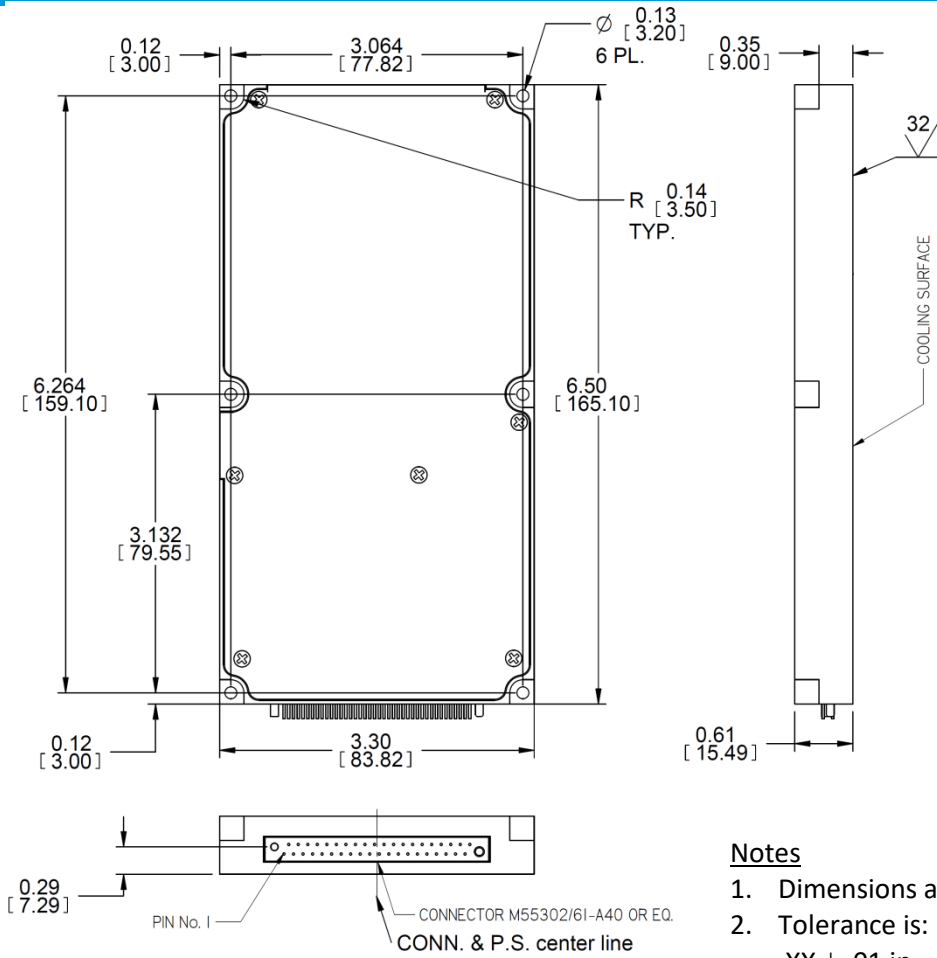

**Notes**

1. Dimensions are in inches [mm]
2. Tolerance is:  
.XX ± .01 in  
.XXX ± .005 in
3. Weight: TBD

**Heat Dissipation Surface Area**

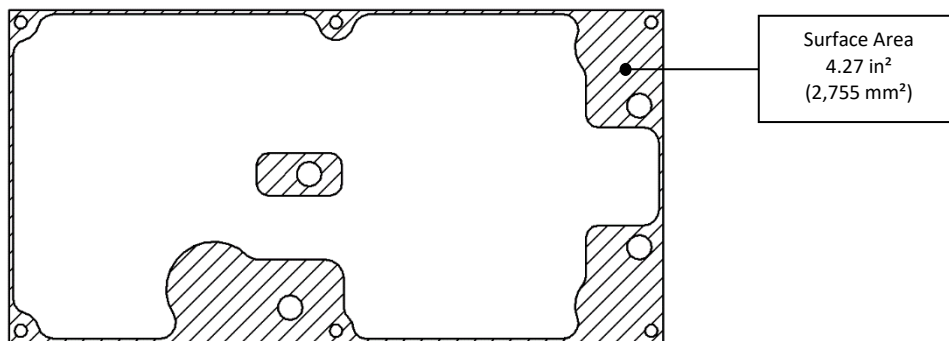

**Note: Specifications are subject to change without prior notice by the manufacture**