

M9204 Series

3.2 kW AC to DC Power Supply

The M9204 is a series of mechanically robust, self-cooled (internal fan), high performance, 3.2kW AC to DC power supplies, designed for Navy shipboard applications. The M9204 converts MIL-STD-1399-300B 3-Phase 440VAC (Delta) 60Hz shipboard power, to a well regulated, filtered and protected DC Output.



Standard Models List (for other voltages – consult factory)

Part Number	DC Output	Rated Current
M9204-102	24VDC	110Amp
M9204-103	28VDC	110Amp
M9204-104	72VDC	45Amp
M9204-105	48VDC	67Amp
M9204-106	80VDC	40Amp

The main features of the M9204 are:

- Complies with the User Interface Requirements of MIL-STD-1399-300B.
- Clean sine-wave input current – less than 3% harmonic current.
- Full-load Power Factor (PF) of above 0.98.
- Inrush current limiting.
- Inhibit Input, BIT and Current Monitor outputs.
- Overload, Overtemperature, Overvoltage and Missing-phase protections.
- Exceptional step-load response.
- Stable operation when loaded by large capacitance loads.
- Self-cooled unit - cooling air is confined to a close-channel heatsink.
- An RPM controlled cooling-fan ensures longer life and higher reliability.
- Full galvanic isolation between Input, Chassis and Outputs.
- Withstands MIL-STD-1399-300B 2,500 V spikes.
- Complies with MIL-STD-461G for shipboard application.
- Complies with MIL-STD-167-1 (Type I) shipboard vibration.
- Robust mechanical design, intended for systems that should withstand MIL-DTL-901E high impact shocks.
- Up to 5 (five) identical M9204 units can be connected in parallel (current share) and provide up to 16KW of regulated and protected power.
- Less than 1/5th of the Human Body Leakage limits of MIL-STD-1399-300B, allowing safe parallel connection of up to five M9204 units.
- J-STD-001B and IPC-610A Class-3 workmanship. Conformal Coating per MIL-I-46058C and IPC-CC-830.

FIELD-PROVEN COTS, MOTS AND CUSTOM MILITARY POWER SOLUTIONS

Specifications:

AC Input	Voltage and Frequency	MIL-STD-1399-300B, Type I, 440VAC/60Hz, 3-Phase Ungrounded Delta. Full performance within the range of 355 V _{AC (L-L)} to 485 V _{AC (L-L)} , 44Hz to 77 Hz. Input surge: up to 594 V _{AC} for 2 sec. No damage for any voltage between 0 to the above limits.
	Power Factor	>0.98 at full load and 50/60Hz.
	Spikes	Withstand 2,500 V spikes IAW MIL-STD-1399-300B.
	Inrush Current	Internally limited such that the peak RMS current is less than 15Arms and recovers to below 6Arms within 50mS.
	Isolation	Input is galvanically isolated from output and chassis (> 20 MΩ at 1,500 V _{DC}). Capacitance between AC input to chassis is less than 0.1μF per line (MIL-STD-1399 compliant). Less than 1mA low-frequency and less than 14mA high-frequency human body leakage (less than 1/5 of the maximum allowed by MIL-STD-1399-300B, allowing safe parallel connection of up to five M9204 units).
	Current Waveform	Low-distortion Sinusoidal, complies with the Harmonic Current limits of MIL-STD-1399-300B.
	Missing Phase Protection	Protected from missing phase. Automatic recovery upon phase restoration.
DC Output	Rating	3.2 kW, models with nominal output voltage of up to 80VDC and rated current up to 110Amp are available (see the Standard Models on Page 1).
	Voltage Regulation	Worst case deviation at the DC output voltage at the Point of Regulation (POR) for all operating and environmental conditions is less than ±1%. No turn-on overshoot.
	Remote Sense	The remote sense lines, when connected to the desired POR (typically at the load) will compensate for up to 2 V _{DC} drop on the output cable.
	Step Load Response	Less than ±1.5V or ±3% (the largest) over/under shoot with recovery time of less than 0.5mS for any 50% load step within the range of 25% to 100% of the full rated load.
	Ripple	Less than 0.25% or 50mVAC (the higher) for all operating and environmental conditions, except that at light loads (below 10%) it may rise but will not exceed 1% or 200mVAC (the higher).
	Isolation	Output is galvanically isolated ("floating") from chassis (> 20 MΩ at 200 V _{DC}). May be grounded at any polarity.
	Current Limit & Overload	Protected from overload and short circuit for indefinite time. Output is current limited (clamped) to 113±12% of the rated current. If an overload pulls the output to below 50±10 % of the nominal output voltage for more than 200mS, the output will shut down for 2 seconds before attempting to recover.
	Efficiency	90% typical. For minimum efficiency see Page 7.
	Overvoltage Protection	Automatic shutdown (latched) if a fault results in above 115±5% of the nominal voltage. Resets upon the recycling of the Inhibit input, or by removing the input power. Will not trip by any AC input transient or step-load (including an abrupt load removal).
	Over Temp. Protection	In case of an Overtemperature the M9204 will shut down and will recover only when its temperature drops back to normal.

Specifications (Cont.):

FIELD-PROVEN COTS, MOTS AND CUSTOM MILITARY POWER SOLUTIONS

Control & Indication	<i>INHIBIT Input</i>	A short to the VDC_ RTN line ($V < 1.2\text{ V @ } 5\text{ mA}$) inhibits the DC Output. Open ($I < 0.1\text{ mA @ } 5\text{V}$) enables the DC Output.
	<i>BIT Output</i>	Isolated open-collector transistor of an Opto-coupler. Low ($V < 0.5\text{ V}_{\text{DC}} @ 2\text{ mA}$): DC Output is enabled and no failure detected. Open ($I < 0.1\text{ mA @ } 20\text{ V}_{\text{DC}}\text{ max}$): disabled or failed DC output.
	<i>Front Panel Green LED</i>	Indicates that DC Output is presents on the Output connector.
	<i>Current Monitor (CRNT_MNTR) Output</i>	Current signal proportional ("mirror") to the load current. For scaling and termination see Page 6 and Page 7.
Environment	<i>Ambient Temperature</i>	Non-operating: -50°C to $+80^{\circ}\text{C}$ Operating: -20°C to $+52^{\circ}\text{C}$.
	<i>Humidity</i>	Up to 95% RH, Per MIL-STD-810F, Method 507.4
	<i>Salt-fog</i>	Per MIL-STD-810F, Method 509.4
	<i>Altitude</i>	Non-operating: (Air transport) up to 40,000 feet.
	<i>Mechanical Shock</i>	40g/11ms and 25g/30mS (Terminal Peak Sawtooth, all directions). Designed for systems that need to comply with MIL-DTL-901E
	<i>Vibration</i>	Type I vibration IAW MIL-STD-167-1. Random Vibration Per MIL-STD-810G, Cat. 24, Fig 514.6E-1.
EMI	<i>MIL-STD-461G</i>	CE101, CE102, CS101 CS114 (10 kHz to 400 MHz, Curve #5), CS115, CS116, RE101, RE102, RS101 and RS103 (2 MHz to 18 GHz 50 V/m). Surface-ship and Internal-submarine limits. All tests are at full load and in accordance with the provisions of MIL-STD-461G – with shielded Output and Signals cables.
	<i>DC Magnetic Field</i>	1600 Amp/m (20 Oersteds) Per MIL-STD-1399 Section 70.
Reliability	MTBF > 115,000 hours when operating at full load in typical Naval (NS) environment.	
Cooling Requirements	The M9204 is a self-cooled unit. It draws ambient air at its front (the I/O connectors' side) and exhaust it at the rear.	
Form factor	6.34" wide, 5" high and 17" deep with four thru-holes removable mounting feet for top side mounting and four blind threaded holes for bottom side mounting (see page 8 and 9). For detailed outlines see drawing: M9204001	
Weight	25 Lbs. (max).	
Connectors	See Page 5	

Pin Assignment:

FIELD-PROVEN COTS, MOTS AND CUSTOM MILITARY POWER SOLUTIONS

J1 - Input		
D38999/20WD5PN (or eq.)		
Pin	Fucntion	AWG#
A	PHASE A	16
B	PHASE B	16
C	PHASE C	16
D	N/C	16
E	CHASSIS	16

J3 - Signals		
D38999/20WB5PN (or eq.)		
Pin	Fucntion	AWG#
A	CRNT_MNTR	
B	INHIBIT	
C	BIT	
D	BIT_RTN	
E	LOADSHARE	

J2 – DC Output					
For: -102, -103, -105			For: -104, -106		
D38999/20WJ19SN (or eq.)			D38999/20WG16SN (or eq.)		
Pin	Fucntion	AWG#	Pin	Fucntion	AWG#
A	VDC_RTN	12	A	VDC_RTN	16
B	VDC_RTN	12	B	VDC_RTN	16
C	VDC_RTN	12	C	VDC_RTN	16
D	VDC_RTN	12	D	VDC_RTN	16
E	VDC_RTN	12	E	VDC_RTN	16
F	P_SENSE	12	F	N_SENSE	16
G	N_SENSE	12	G	P_SENSE	16
H	+VDC	12	H	+VDC	16
J	+VDC	12	J	+VDC	16
K	+VDC	12	K	+VDC	16
L	+VDC	12	L	+VDC	16
M	+VDC	12	M	+VDC	16
N	+VDC	12	N	VDC_RTN	16
P	VDC_RTN	12	P	VDC_RTN	16
R	VDC_RTN	12	R	+VDC	16
S	VDC_RTN	12	S	+VDC	16
T	+VDC	12			
U	+VDC	12			
V	VDC_RTN	12			

Typical Signals interface

FIELD-PROVEN COTS, MOTS AND CUSTOM MILITARY POWER SOLUTIONS

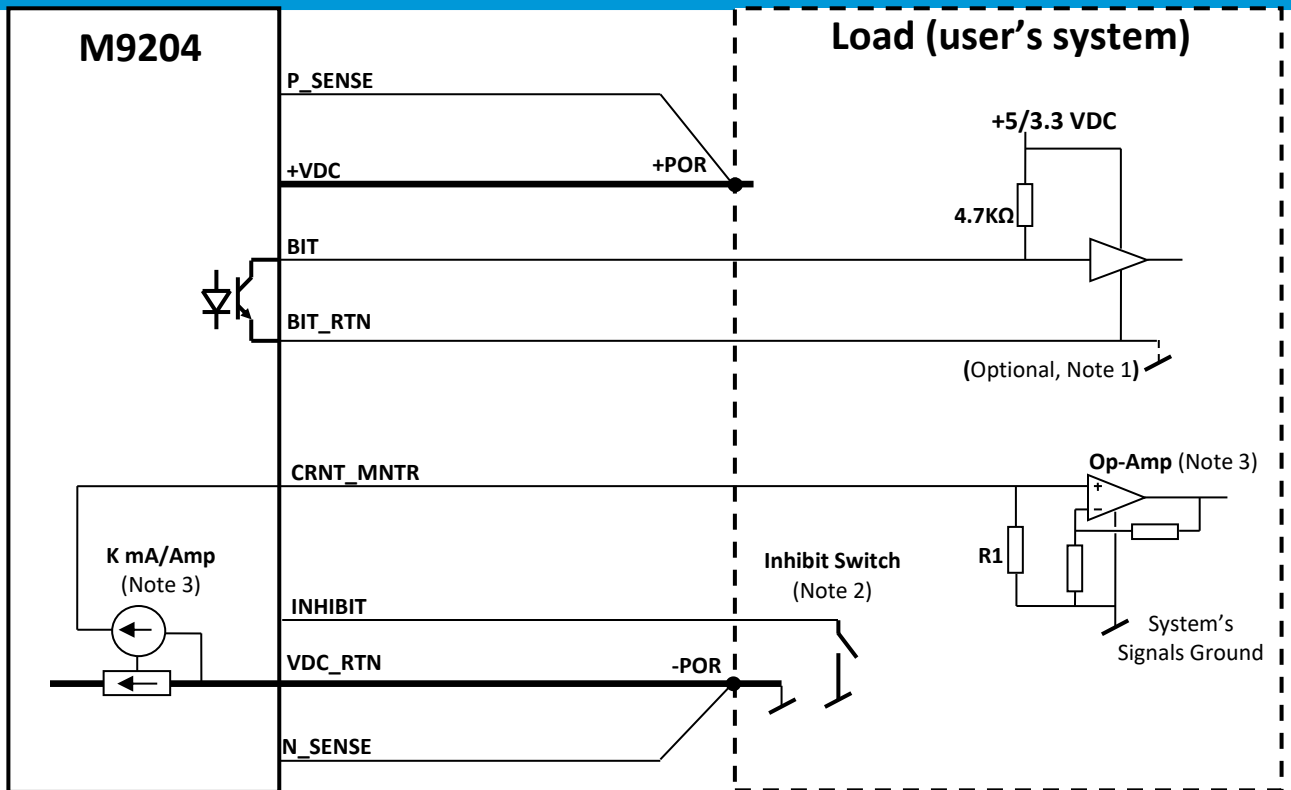

Notes:

1. The BIT_RTN signal can be tied to VDC_RTN or any other signal or Ground.
2. When the INHIBIT input is shorted to VDC_RTN it disables the DC output. It can be a small-signal switch, or an electronic device such as the transistor of an optocoupler or an open-drain signal.
3. The signal's level (Volts per Amp) can be adjusted by selecting the value of R1. For the mirror factor (K) and the maximum value of R1 that ensures full scale reading, see Page 7. Placing R1 near the sensing circuit (Op-Amp, V-Comparator or A-to-D) will ensure that the accuracy of the reading will not be affected by the voltage drop on the VDC_RTN feed lines.
4. To meet MIL-STD-461G radiation limits, the DC-output and Signal cables (J2 and J3) should be adequately shielded.
5. To enable current sharing when using a few identical M9204 in parallel:
 All +VDC pins and P_SENSE of all parallel supplies should be connected to a single point.
 All VDC_RTN pins and N_SENSE of all parallel supplies should be connected to a single point.
 The LOADSHARE pins of all the paralleled supplies should be tied together.

Standard Configurations:

FIELD-PROVEN COTS, MOTS AND CUSTOM MILITARY POWER SOLUTIONS

Standard Models Data (for other output voltage/current – consult factory)

Part Number	Output Voltage	Rated Current	Minimum Efficiency	Current Monitor	
				K Factor mA/Amp	Max Sense Resistor (R1)
M9204-102	24VDC	110Amp	88%	0.05	0.8K
M9204-103	28VDC	110Amp	89%	0.05	0.8K
M9204-104	72VDC	45Amp	90%	0.1	1.0K
M9204-105	48VDC	67Amp	90%	0.05	1.3K
M9204-106	80VDC	40Amp	90%	0.1	1.1K

FIELD-PROVEN COTS, MOTS AND CUSTOM MILITARY POWER SOLUTIONS

Outline Dimensions:

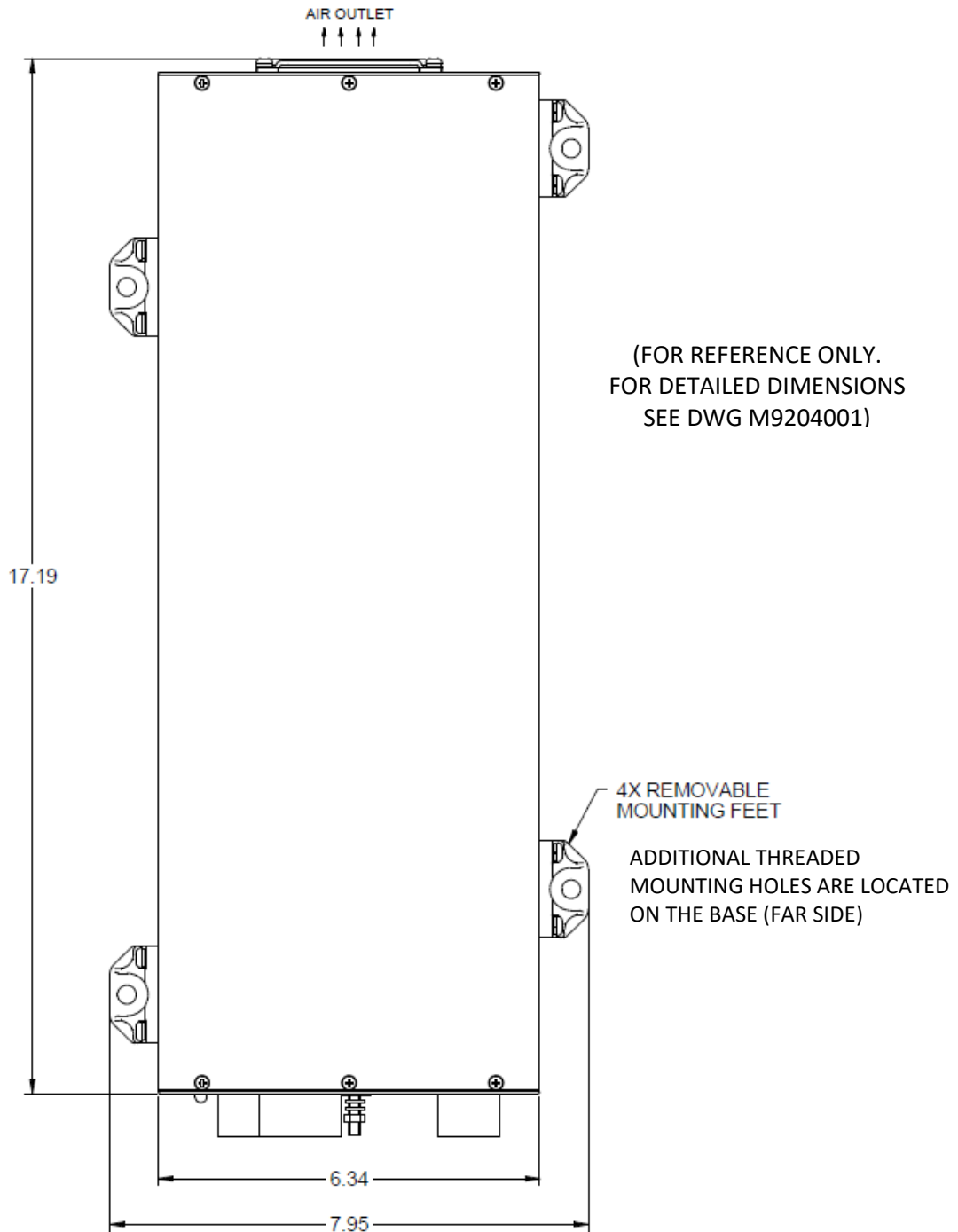

(FOR REFERENCE ONLY.
FOR DETAILED DIMENSIONS
SEE DWG M9204001)

4X REMOVABLE
MOUNTING FEET
ADDITIONAL THREADED
MOUNTING HOLES ARE LOCATED
ON THE BASE (FAR SIDE)

TOP VIEW

FIELD-PROVEN COTS, MOTS AND CUSTOM MILITARY POWER SOLUTIONS

(FOR REFERENCE ONLY.
FOR DETAILED DIMENSIONS
SEE DWG M9204001)

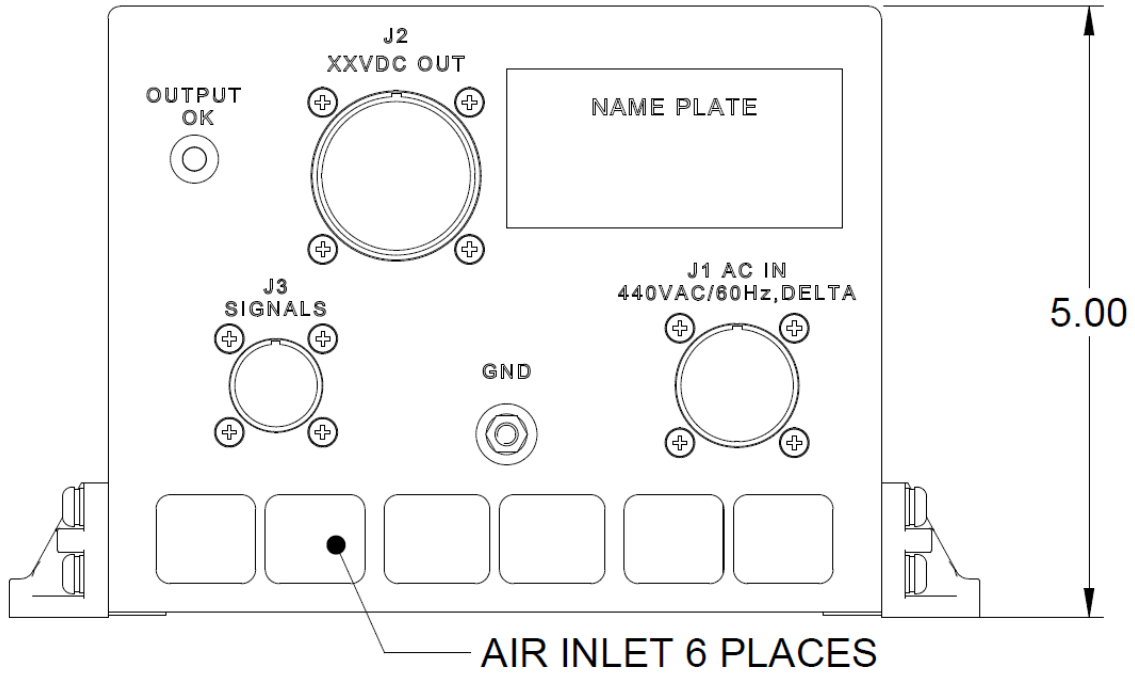

FRONT VIEW

Note: Specifications are subject to change without prior notice by the manufacturer