

M9205 Series

3.6 kW AC to High Voltage DC Power Supply

The M9205 is a series of mechanically robust, base-plate cooled, high performance, 3.6kW AC to DC power supplies, designed for Navy shipboard applications. The M9205 converts MIL-STD-1399-300B

3-Phase 440VAC (Delta) 60Hz shipboard power, to a well-regulated, filtered and protected high-voltage DC Output.



Standard Models List (for other voltages – consult factory)

Part Number	DC Output	Rated Current
M9205-108	260VDC	13.5Amp
M9205-109	270VDC	13.5Amp
M9205-110	300VDC	12Amp
M9205-111	360VDC	10Amp

The main features of the M9205 are:

- Complies with the User Interface Requirements of MIL-STD-1399-300B.
- Clean sine-wave input current – less than 3% harmonic current.
- Full-load Power Factor (PF) of 0.99.
- Inrush current limiting.
- Enable Input, BIT and Current Monitor outputs.
- Overload, Overtemperature, Overvoltage and Missing-phase protections.
- Exceptional step-load response.
- Can drive large capacitive loads.
- Conduction cooled via its baseplate.
- Full galvanic isolation between Input, Chassis and Outputs.
- Withstands MIL-STD-1399-300B 2,500 V spikes.
- Complies with MIL-STD-461F for shipboard application.
- Complies with MIL-STD-167-1 (Type I) shipboard vibration.
- Robust mechanical design, intended for systems that should withstand MIL-DTL-901E high impact shocks.
- Up to 10 (ten) M9205 can be connected in parallel (current share) and provide up to 36 kW of regulated and protected power.
- Less than 10% of the Human Body leakage allowed by MIL-STD-1399-300B. Allows safe connection of up to 10 parallel units.
- J-STD-001B and IPC-610A Class-3 workmanship.
- Conformal Coating per MIL-I-46058C and IPC-CC-830.

M9205 Series– AC/DC Power Supply

Specifications:

AC Input	Voltage and Frequency	MIL-STD-1399-300B, Type I, 440VAC/60Hz, 3-Phase Ungrounded Delta. Full performance within the range of 355 V _{AC (L-L)} to 485 V _{AC (L-L)} , 44Hz to 77 Hz. Input surge: up to 594 V _{AC} for 2 sec. No damage for any voltage between 0 to the above limits.
	Power Factor	>0.98 at full load and 50/60Hz.
	Spikes	Withstand 2,500 V spikes IAW MIL-STD-1399-300B.
	Inrush Current	Internally limited such that the peak RMS current is less than 15Arms and recovers to below 6Arms within 50mS.
	Isolation	Input is galvanically isolated from output and chassis (> 20 MΩ at 1,500 V _{DC}). Capacitance between AC input to chassis is less than 0.1μF per line (MIL-STD-1399-300B compliant). Less than 0.5mA low-frequency and less than 7mA high-frequency human body leakage (less than 1/10 of the maximum allowed by MIL-STD-1399-300B, allowing safe parallel connection of up to ten M9205 units).
	Current Waveform	Low-distortion Sinusoidal, complies with the Harmonic Current limits of MIL-STD-1399-300B.
	Missing Phase Protection	Protected from missing phase. Automatic recovery upon phase restoration.
DC Output	Rating	3.6 kW, models with nominal output voltage of up to 360VDC and rated current up to 13.5Amp are available (see the Standard Models table on Page 1).
	Voltage Regulation	Worst case deviation of the DC output voltage at the Point of Regulation (POR) for all operating and environmental conditions is less than ±1% (±0.5% available upon request). No turn-on overshoot.
	Step Load Response	With a step load of 20% to 100% (50μS rise/fall time), the over/under shoot is less than ±2% with recovery time of 2mS.
	Ripple	Less than 0.25% for all operating and environment conditions, except that at light loads (below 0.6 Amp) it may rise, but will not exceed 1%.
	Isolation	Output is galvanically isolated (“floating”) from chassis (> 20 MΩ at 1,000 V _{DC}).
	Current Limit & Overload	Output current is actively limited (clamped) to 113±12% of the rated current. A sustained overload that pulls the output voltage below 83±5% of the nominal voltage for more than 50mS (can be extended upon request) will trip the Overload protection and disable the output. During turn-on, the Overload delay is extended to 150mS. Resets when the Enable input is recycled, or input power removed. (An automatic recovery is available upon request).
	Efficiency	91% minimum (92% typical) at full load.
Overvoltage Protection	Automatic shutdown in case of a fault that causes the output voltage to exceed 115±5% of the nominal voltage. Resets when the Enable input is recycled or input power removed.	
Over Temp. Protection	In case of an Overtemperature the M9205 will shut down and will recover when its temperature drops back to normal.	

M9205 Series– AC/DC Power Supply

Specifications (Cont.):

Control & Indication	Enable Input	An opto-isolated input (the diode of an Optocoupler via 1K resistor). High ($V > 3.5V_{DC}$ or $I > 2.5mA$) enables the DC output. Low/Open ($V < 0.5V_{DC}$, or $I < 0.2mA$) disables the DC output. Maximum allowed voltage is 7.5V.
	BIT Output	Isolated open-collector transistor of an Opto-coupler. Low ($V < 0.5 V_{DC}$ @ 2 mA): DC Output is enabled and no failure detected. Open ($I < 0.1 mA$ @ 20 V_{DC} max): disabled or failed DC output.
	Front Panel Green LED	Indicates that DC Output is presents on the Output connector.
	Current Monitor (CRNT_MNTR) Output	Proportional current signal that mirrors the load current with a scaling of 1mA/10Amp (referenced to DC_RTN). Full scale of 5V (at 15Amp) when terminate to VDC_RTN by 3.33 k Ω resistor.
Environment	Temperature	Non-operating ambient : -50°C to +85°C Operating ambient: -35°C to + 85°C (see Cooling Requirements below).
	Humidity	Up to 95% RH, Per MIL-STD-810F, Method 507.4
	Salt-fog	Per MIL-STD-810F, Method 509.4
	Altitude	Non-operating: (Air transport) up to 40,000 feet.
	Mechanical Shock	40g/11ms and 25g/30mS (Terminal Peak Sawtooth, all directions). Designed for systems that need to comply with MIL-DTL-901E
	Vibration	Type I vibration IAW MIL-STD-167-1. Random Vibration Per MIL-STD-810G, Cat. 24, Fig 514.6E-1.
EMI	MIL-STD-461F	CE101, CE102, CS101 CS114 (10 kHz to 400 MHz, Curve #5), CS115, CS116, RE101, RE102, RS101 and RS103 (2 MHz to 18 GHz 50 V/m). Surface-ship and Internal-submarine limits. All tests are at full load and in accordance with the provisions of MIL-STD-461F – with shielded Output and Signals cables.
	DC Magnetic Field	1600 Amp/m (20 Oersted) Per MIL-STD-1399 Section 70.
Reliability	MTBF > 165,000 hours for a typical Naval (NS) environment.	
Cooling Requirements	The M9205 is a baseplate cooled unit. The base of the M9205 (see Form Factor below) should be thermally attached to a suitable heatsink that maintains it below +85 °C.	
Form factor	6.34" wide, 4.5" high and 14" deep, with 10 threaded (.164-32 UNC) blind mounting holes on its 6.34 by 14 base that should be mechanically and thermal attached to a user provided cold-plate (see Page 7 and 8). For detailed dimensions and tolerances see Drawing: M9205110	
Weight	20 Lbs. (max).	
Connectors	See page 5	

M9205 Series– AC/DC Power Supply

Pin Assignment:

The connectors P.N.s are of the receptacles on the M9205.

J1 – AC Input D388999/20WD5PN		
Pin	Function	AWG
A	PHASE A	#16
B	PHASE B	#16
C	PHASE C	#16
D	N/C	#16
E	CHASSIS GND	#16

Phase order is not essential.

J2 – DC Output and Signals D38999/20WD18SN			
Pin	Function	I/O	AWG
A	BIT	O	#20
B	VDC_RTN	O	#20
C	VDC_RTN	O	#20
D	VDC_RTN	O	#20
E	LS	I/O	#20
F	ENABLE	I	#20
G	ENABLE_RTN	I	#20
H	+VDC	O	#20
J	+VDC	O	#20
K	+VDC	O	#20
L	BIT_RTN	O	#20
M	CRNT_MNTR	O	#20
N	N/C	-	#20
P	VDC_RTN	O	#20
R	N/C	-	#20
S	N/C	-	#20
T	+VDC	O	#20
U	N/C	-	#20

M9205 Series– AC/DC Power Supply

Typical Signals interface

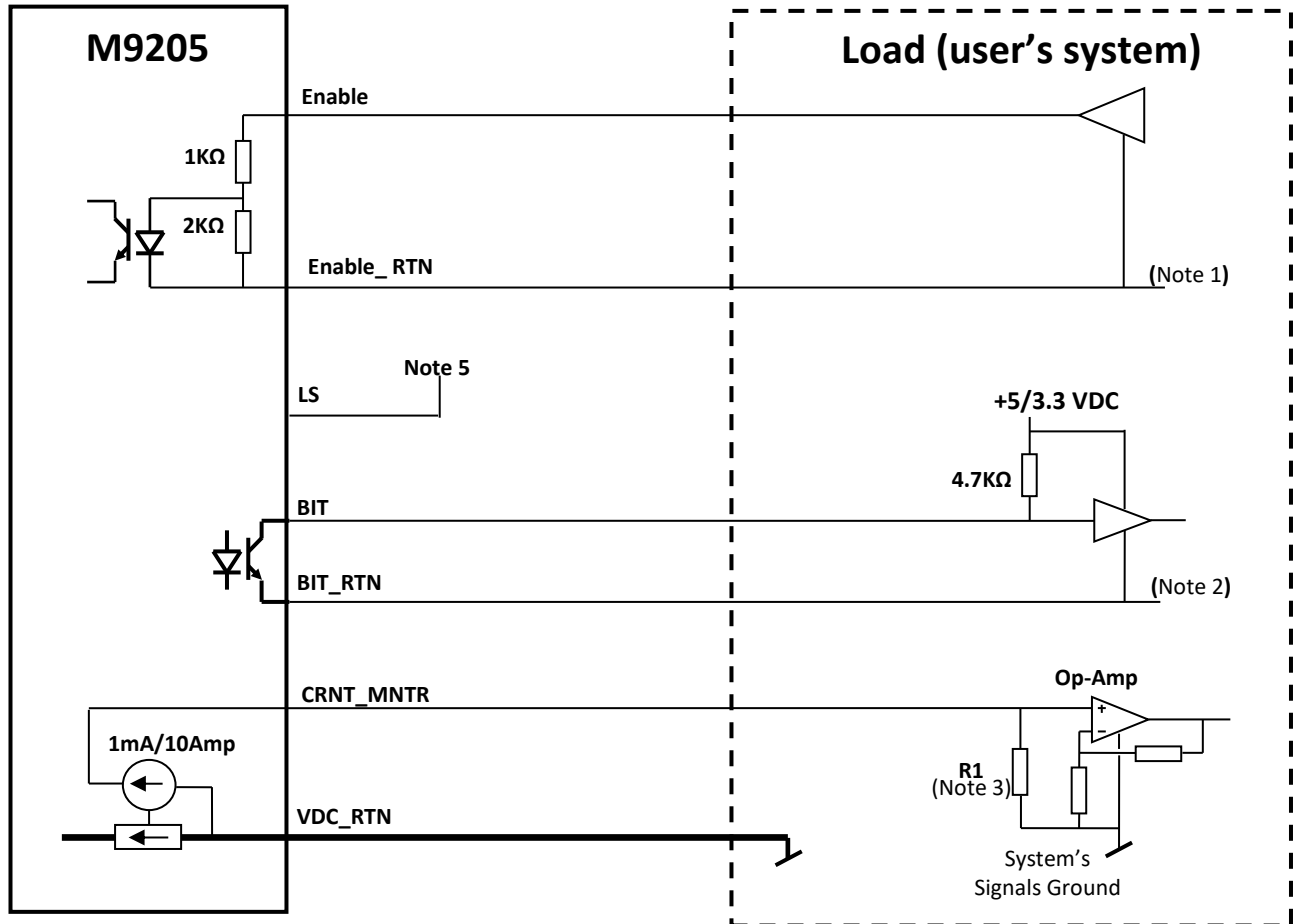

Notes:

1. The Enable_RTN can be tied to the VDC_RTN or any other signal or Ground. To enable the output the source of the Enable signal should provide at least 2.5mA into 3.5Vdc (but should not exceeds 7.5Vdc or 7mA).
2. The BIT_RTN can be tied to VDC_RTN or any other signal or Ground.
3. To ensure that the accuracy of the current monitor sensing will not be affected by the voltage drop on the VDC_RTN line, R1 should be located near the sensing amplifier (or A to D converter). The volts per amp scaling is set by the value of R1. For a full scale of 5V at 15Amp use 3.33 kΩ.
4. To meet MIL-STD-461G radiation limits, the DC-output cables should be adequately shielded.
5. To enable current sharing when using a few identical M9205 units in parallel:
Connect all +VDC pins of all the parallel units to a single point.
Connect all VDC_RTN pins of the parallel units to a single point.
Tie together the LS pins of all the parallel units.

M9205 Series– AC/DC Power Supply

Outline Dimensions



TOP VIEW

(THREADED MOUNTING HOLES ARE ON THE FAR SIDE)

(FOR REFERENCE ONLY.
FOR DETAILED DIMENSIONS
SEE DWG M9205110)

M9205 Series– AC/DC Power Supply

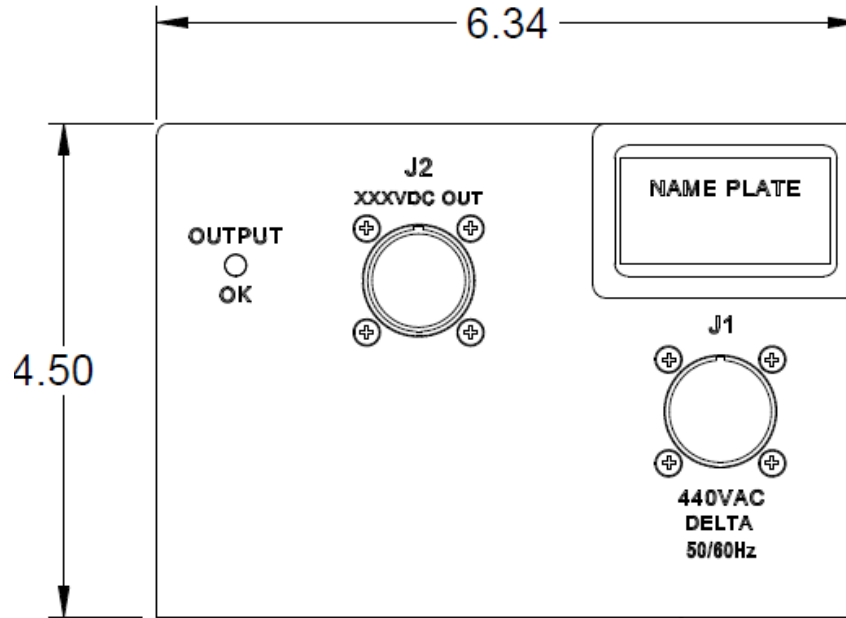

COOLING SURFACE WITH
THREADED MOUNTING HOLES

FRONT VIEW

(FOR REFERENCE ONLY.
FOR DETAILED DIMENSIONS
SEE DWG M9205110)

Note: Specifications are subject to change without prior notice by the manufacturer