

M6620-101

SINGLE-OUTPUT, UP TO 2500W AC/DC POWER SUPPLY

The M6620 power supply / Battery Changer is an innovative power system designed for harsh outdoor / indoor environments.

The combination of convection cooling and IP68 rating enables operation in the harshest environment.

Digital communication enables dynamic control of output voltage / current utilized. Internal MCU enables supervision of battery temperature and charge current to elongate battery life, optional - smart battery charging of any chemistry.



Part number	Input		Output	
	Voltage range	Frequency	Nominal Voltage	Current
M6620-101	85-265VAC/Single phase	50/60Hz	28V	90 A

M6620 POWER SUPPLY SYSTEM BLOCK DIAGRAM:

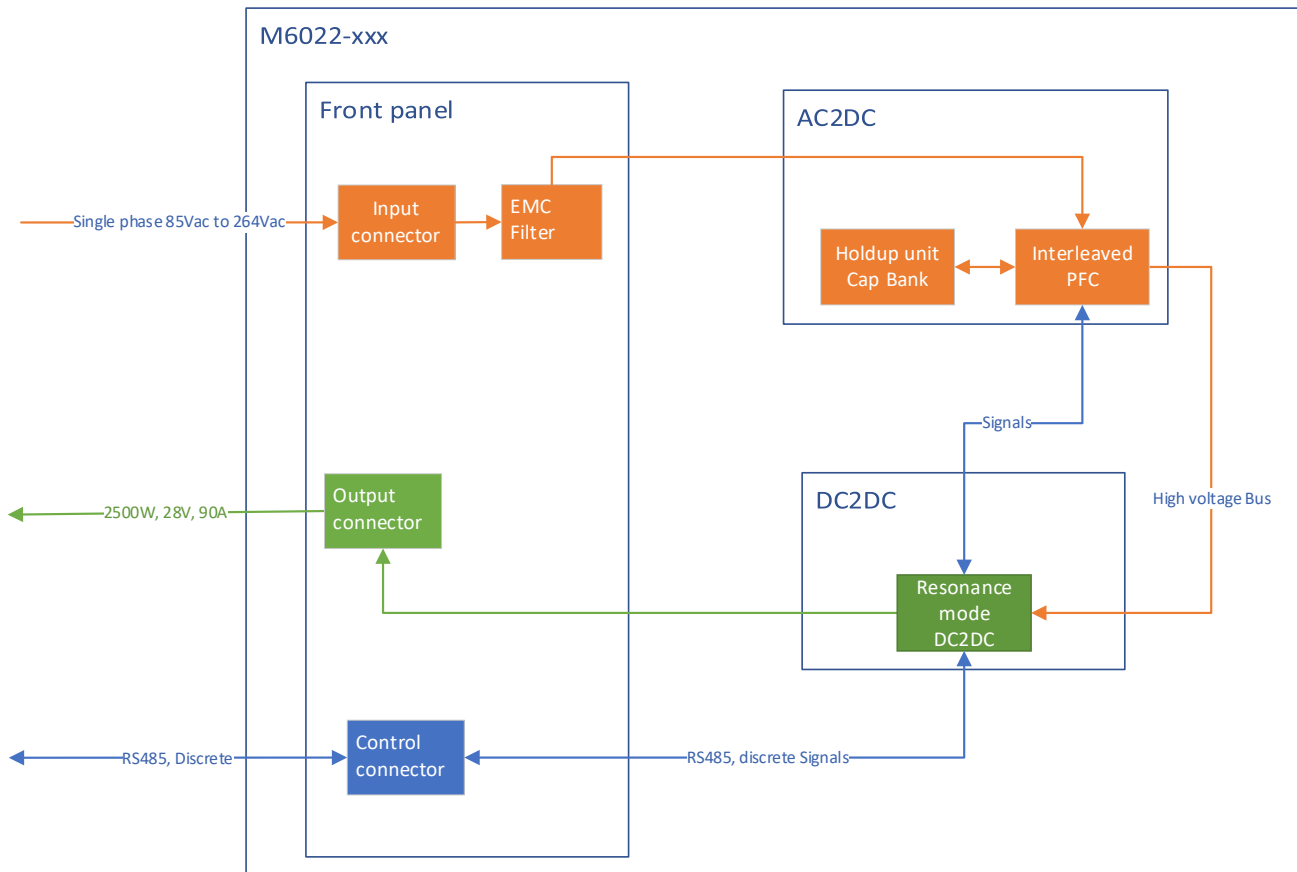

THE MAIN FEATURES OF THE M6620-101:

- Operate from single-phase grid.
- Natural convection cooled.
- Wide output voltage range:
 - o 18V to 34V for the 28V.
 - o Optional: 38V to 64V for the 48V-please consult factory.
- Discreet signals.
- RS485 communication control.
- Active current sharing – 95% accuracy.
- Batteries can be any chemistry (battery type configured using firmware update / communication).
- Smart battery charging (optional, please consult factory):
 - o Charge curve can be customized as required, see battery charging section, consult vendor for more information.
 - o Battery temperature monitoring and compensation (remote sensing fixture required or junction box).
 - o auxiliary voltage for current sense clamp.
 - o Limiting battery charge current while delivering full power to the system (requires current clamp to sense the battery current or remote sensing fixture required or junction box).
 - o Reverse battery connection protection.
 - o Reverse discharge protection, Battery discharge into PSU is less than 1mA.
- Hiccup / constant current OCP options.
- RS485 communication.
- Ethernet, CAN, Ether-CAT, communication – (requires communication fixture).
- Dynamically controlled OCP via communication.
- Optional, Latch up or auto recovery from all protections.
- Front panel LED indications.
- MIL-STD-D38999 connector.

SPECIFICATIONS:

AC Input	Voltage Range	85Vac ~ 264Vac 50/60Hz Single phase												
	Isolation	Input to output / case 2500Vac Input to Signals 2500Vac												
	Inrush Current Limiter	<50A												
	Circuit Breaker	Input circuit breaker – single pole												
	OVP	275Vac +- 5V												
	UVP	80Vac +-5V												
DC Output	Rating	Nominal output voltage 28V Output voltage range - 18to 34V min load needed under 26V: <table border="1" style="margin-left: auto; margin-right: auto;"> <thead> <tr> <th>Required load (A)</th> <th>Vout (V)</th> </tr> </thead> <tbody> <tr> <td>0.25</td> <td><= 26V</td> </tr> <tr> <td>0.5</td> <td><= 24V</td> </tr> <tr> <td>1</td> <td><= 22V</td> </tr> <tr> <td>5</td> <td><= 20V</td> </tr> <tr> <td>10</td> <td><= 18V</td> </tr> </tbody> </table>	Required load (A)	Vout (V)	0.25	<= 26V	0.5	<= 24V	1	<= 22V	5	<= 20V	10	<= 18V
		Required load (A)	Vout (V)											
	0.25	<= 26V												
	0.5	<= 24V												
	1	<= 22V												
5	<= 20V													
10	<= 18V													
Max output Power – high line 2500W at 230Vac input Max output Power – low line 2500W at 115Vac input Max output Power 2000W when input is < 100V														
Nominal output voltage 48V Output voltage range - 38V to 64V min load under 44V – consult factory														
Max output Power – high line 2500W at 230Vac input Max output Power – low line 2500W at 115Vac input Max output Power 2000W when input is < 100V														
Voltage Regulation	Less than 2% (no load to full load, -40 °C to +60 °C with recommended convection cooling)													
Ripple and Noise	100 - 150 mVp-p typical (max 1% @ 28V) with a 10µF ceramic capacitors parallel to the load.													
Isolation	Output to case 250V Signals to case 250V													

M5628-101 - AC/DC Power Supply

	Current Limit & Overload	Continuous protection (constant current) for unlimited time. Maximum over current protection – 95A +-5A load exceeds max load threshold, under pre-defined voltage (Default - 14V). - CC mode level can be adjusted using communication command.
	Efficiency	92% Typical at 28V @ 2500W output Vin 230Vac.
	Overvoltage Protection	Overvoltage Protection at 36V +-1V of nominal voltage.

Specifications (Cont.):

Environment Designed to meet MIL-STD-810F	Temperature	Operating: -40 °C to +60°C (ambient). Operating: -40 °C to +90°C (case). Storage: -40 °C to +85°C
	Shock	Method 516.5 Method 516.6
	Sand and dust	Method 510.4, procedure I & II (blowing dust). Method 510.5, procedure I (blowing dust).
	Fungus	method 508.5 method 508.6
	Salt atmosphere	method 509.4 method 509.5
	Wind	Up to 20M/Sec gusts of 40M/Sec
	Acceleration	method 513.6
	Immersion	Method 512.1
	Mechanical Shock	Method 516.5 Method 516.6
	Vibration	Method 514.6
IP	IP rating	Designed to meet IP67/8

M6620-101 - AC/DC Power Supply

EMI	<i>Designed to meet MIL-STD-461F*</i>	CE102	conducted emissions, power leads, 10 kHz to 10 MHz	Figure CE102-1, Basic Curve for 28VDC
		CS101	conducted susceptibility, power leads, 30 Hz to 150 kHz	FIGURE CS101-1, Curve #2 for 28VDC
		CS114	Conducted Susceptibility, Bulk Cable Injection, 10 kHz to 200 MHz;	FIGURE CS114-1, Curve #5 for Ground Army
		CS115	Conducted Susceptibility, Bulk Cable Injection,	FIGURE CS115-1
		CS116	Conducted Susceptibility, Damped Sinusoidal Transients, Cables and Power Leads, 10 kHz to 100 MHz;	FIGURE CS116-2
		*CS117	conducted susceptibility, lightning induced transients, cables and power leads.	All equipment installations, External Equipment Levels
		CS118	Personnel Borne Electrostatic Discharge	TABLE VIII, ±8 contact and ±15 air
		RE102	Radiated Emissions, electric field, 10 kHz to 18 GHz	RE102 limit for Ground Army
		RS103	Radiated Susceptibility, electric field, 2 MHz to 18 GHz	Table XI, RS103 Ground Army, 50V/m
				* Compliance is achieved when using a shielded enclosure and interconnection cable.
	<i>Indirect lightning⁽¹⁾</i>	Indirect lightning pass/fail criteria - loss of function with permanent damage to equipment. paragraph A.5.4		

	Grounding and bonding⁽¹⁾	The unit shall include the necessary electrical bonding to meet the E3 requirements of the standard. Compliance shall be verified by test. paragraph A.5.10		
	IEC/EN61000-4-5⁽¹⁾	Testing and measurement techniques – Surge immunity test. Class level 2		
	Voltage Dips⁽¹⁾ IEC 61000-4-11 IEC 61000-4-34	<p><u>For PSU mode @ 28V:</u> 0% for one AC line cycle - output voltage drops by less than 10%. 70% for 25/30 AC line cycles (0.5 Sec) - output voltage drops by less than 10%.</p> <p><u>For battery charger mode (18V to 34V):</u> 0% for <u>half AC line cycle</u> - output voltage drops by less than 10%. 70% for <u>5/6 AC line cycles</u> (0.1 Sec).</p>		
Safety⁽¹⁾	EN62368-1: Ed.3			
Form factor	239.5mm wide, 186mm height and 446.5mm deep. For detailed dimensions and tolerances see Drawing: M6620001			
Weight	Approx. 19 kg Typical			
Connectors	Reference	Function	Connector P/N	Mating Connector P/N
	J1	AC Power Input	8D7C17W06PN or Eq.	8D517W06SN or Eq.
	J2	DC Power Output ⁽²⁾	8D7C21W11SN or Eq.	8D521W11SN or Eq.
	J3	signals	8D7L13W35SN or Eq.	8D513W35PN or Eq.
	J4 J5	Daisy Chain for parallel Operation	8D7L09W35SN or Eq.	8D509W35PN or Eq.

Notes:

1. Designed to meet
2. Optional J2 can be replaced with a RadSok type.
Output connectors: ALM07F21-11D(RDS)(036)(SP).
Requires mating: ALM06F21-11P(036).

PIN ASSIGNMENT:

User Signal	J3
Part number	8D7L13W35SN or Eq.
Pin	Function
1	NC
2	NC
3	Aux 12V
4	Aux 5V0
5	Sig Ret
6	Batt_current_sns_p
7	Batt_current_sns_n
8	Sig Ret
9	GP_output *
10	Battleshort
11	ext_ntc_a
12	ext_ntc_b
13	NC
14	RS_485_A
15	RS_485_B
16	NC
17	Power_good
18	Inhibit
19	Sig Ret
20	NC
21	Remote_sns_P
22	Remote_sns_N

AC input	J1
Part number	8D7C17W06PN oe Eq.
Pin	Function
A	Phase
B	Neutral
C	Earth
D	Earth
E	Phase
F	Neutral

DC out	J2
Part number	8D7C21W11SN or Eq.
Pin	Function
A	Vout_ret
B	Vout_ret
C	Vout_p
D	Vout_p
E	Vout_p
F	Vout_p
G	Vout_p
H	Vout_ret
J	Vout_ret
K	Vout_ret
L	Vout_p

- GP_output – functionality can be defined according to customer request
Consult factory for more information.

CS Signals	J4
Part number	8D7L09W35SN or Eq.
1	NC
2	CS_Bus_P
3	CS_Bus_N
4	CS_Master
5	NC RS_485_A *OPTIONAL
6	NC RS_485_B *OPTIONAL

CS Signals	J5
Part number	8D7L09W35SN or Eq.
1	NC
2	CS_Bus_P
3	CS_Bus_N
4	CS_Master
5	NC RS_485_A *OPTIONAL
6	NC RS_485_B *OPTIONAL

FRONT PANEL LED INDICATIONS:

Two RGB LED are available of the front panel.

The LED state indicates the current PSU state as described in the following table:

System state / Error	LED 1 (Left)	LED 2 (Right)	blink frequency and D.C.		Remarks
			LED 1	LED 2	
MCU on	White	White			During MCU power up
AC ok	Green	-			AC voltage in range
DC out ok	-	Green		1Hz 90%	PSU powered on, in CC slave mode LED 2 not blinks
AC under voltage	Red	-			AC voltage too low
AC over voltage	Red Blink	-	1Hz 50%		AC voltage too high
Light OCP CC mode	-	Green Blink		1Hz 50%	The PSU entered constant current mode
Hiccup	-	Red Blink		1Hz 50%	Extreme overload, PSU entered hiccup mode.
Revers Battery	-	Orange			Revers voltage detected on the output terminals
OTP	Orange Blink	Orange Blink	1Hz 50%	1Hz 50%	Internal temperature too high
UTP	Purple Blink	Purple Blink	1Hz 50%	1Hz 50%	Internal temperature too low
Internal error or unexpected event.	-	Purple			Miscellaneous – any error that not defined in the table. unexpected event, example: line voltage change from 230 to 115.

- If two or more errors occur simultaneously, only one state will be indicated.

DISCRETE SIGNALS INTERFACE

Discrete signals functionality and default states can be modified in firmware.
So, the active state and default level can be modified in firmware.

DIGITAL SIGNAL DEFAULT SETTINGS:

	Signal name	Direction	Default behavior if left open	Defined active state	Remarks
1	Inhibit	input	System powered on	Pulled low to Sig Ret	
2	Battle short	Input	Not implemented	Not implemented	
3	Power good	output	NA	Pulled low to Sig Ret	
4	GP_output	output	NA	User defined	

ELECTRICAL CHARACTERISTICS:

These signals are galvanically isolated from the PSU output
These signals refer to "Sig Ret".

DIGITAL OUTPUT SIGNALS:

- Power_good.
- GP_output.

Output signals are pulled up to 12V through 10k OHM resistor in inactive state.
Output signals are pulled to Sig Ret if in an active state.

FRONTEND CIRCUIT:

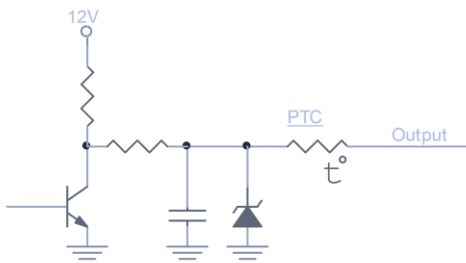

DIGITAL INPUT SIGNALS:

- Inhibit.
- Battle short.

Input signals are pulled up to 12V through 20k OHM resistor, Pull to Sig Ret to put in an active state.

FRONTEND CIRCUIT:

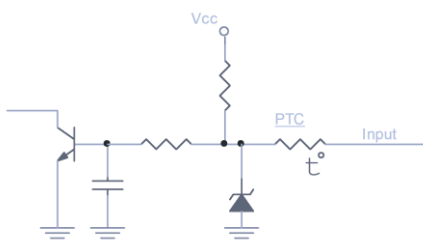

Notes:

- It's not recommended to apply voltage to the input signal.
- If voltage applied to an input before ac power applied, the level sampled by the M6620 is undefined and may be latched, toggle the input to release.

ANALOG SIGNALS:

- External NTC (analog pairs: "ext_ntc_a" and "ext_ntc_b").
See Battery charging options.
- Battery current sense (differential pairs: Batt_current_sns_p and Batt_current_sns_n).
Optional - the M6620 can monitor the battery current and limit the charge current as required by specific battery chemistry – contact vendor for more information.
Optional – the M6620 can estimate the battery DOC by implementing a fuel gauge – contact vendor for more information.
- Remote sense, (analog pairs: "Remote_sns_P" and "Remote_sns_N") used to compensate for wire voltage drop or monitor battery voltage.

ACTIVE CURRENT SHARING:

Active current sharing mechanism enables connecting M6620 units in parallel, if more than 2 (two) units are required, please contact vendor.

The current sharing mechanism requires three signals: "CS_Master", "CS_Bus_P", "CS_Bus_N".

Using J4 and J5, Connect a harness between the paralleled M6620 units.

Note, a single RS485 bus used for control connector J3 and J4, J5

FRONTEND CIRCUIT:

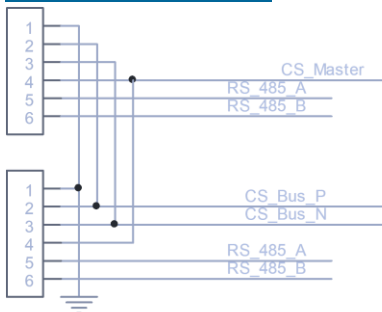

COMMUNICATION:

The M6620 power supply system supports RS485 communication. System parameters can be monitored using periodic communication commands. Default communication settings: Boud rate 115200bps, 8 data bits, no parity, one stop bit. Minimum ideal time between communication transaction (ideal bus time) is 100mSec. Command received before the ideal bus time ends will be ignored. Some parameters can be modified by communication commands. For communication protocol details please see doc "DS_M6620-xxx RS485_Comm".

RS485, FRONTEND CIRCUIT:

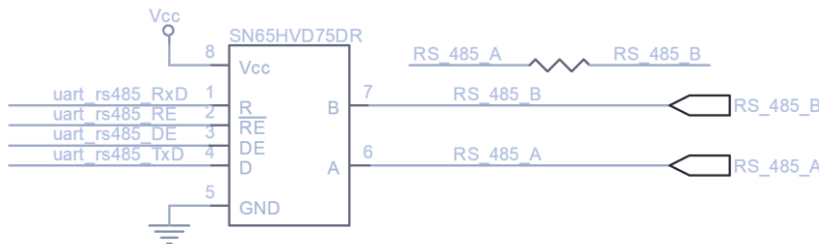

COMMAND SET SUMMARY:

	Command	Constrains	Remarks
1	Set RS485 address	Can be issued only when the M6620 is in off (inhibit) state	Stored in non-volatile memory
2	Set default parameters	Can be issued only when the M6620 is in off (inhibit) state	Stored in non-volatile memory
3	Update nominal parameters	Always Available	Value reset to default if power cycles
4	Set output voltage	Always Available	
5	Set output current limit	Always Available	
6	Power on	Always Available	
7	Power off	Always Available	
8	Blink LED RGB	Can be issued only when the M6620 is in off (inhibit) state	LED functionality check
9	Get serial number	Can be issued only when the M6620 is in off (inhibit) state	
10	Get serial number reply	Can be issued only when the M6620 is in off (inhibit) state	
11	Get Firmware version	Can be issued only when the M6620 is in off (inhibit) state	
12	Get Firmware version reply	Can be issued only when the M6620 is in off (inhibit) state	
13	Get HW version	Can be issued only when the M6620 is in off (inhibit) state	
14	Get HW version reply	Can be issued only when the M6620 is in off (inhibit) state	
15	Get internal counters	Always Available	
16	Get internal counters reply	Always Available	
17	Ger current params	Always Available	
18	Ger current params reply	Always Available	
19	Get nominal parameters	Always Available	
20	Get nominal parameters reply	Always Available	
21	Get default params	Always Available	
22	Get default params reply	Always Available	

BATTERY CHARGING: - OPTIONAL PLEASE CONSULT FACTORY.

The M6620 can be used as a smart battery charger

The following charging modes are available: constant current, constant voltage, float. (optional Equalizing mode).

Optional – the M6620 can monitor the battery pack temperature and compensate for battery charge voltage / current, this can be used to prevent gassing.

As default, the system supports the Vishay "NTCALUG01T103G501A" NTC thermistor. – contact vendor for more information on using other thermal sensors.

A current sensor module can be connected to J3, it can be used to sample the battery current separately from the load current – it enables more flexible and optimal battery charging to extend battery life.

If more than one unit in parallel is required for battery charging, please consult factory.

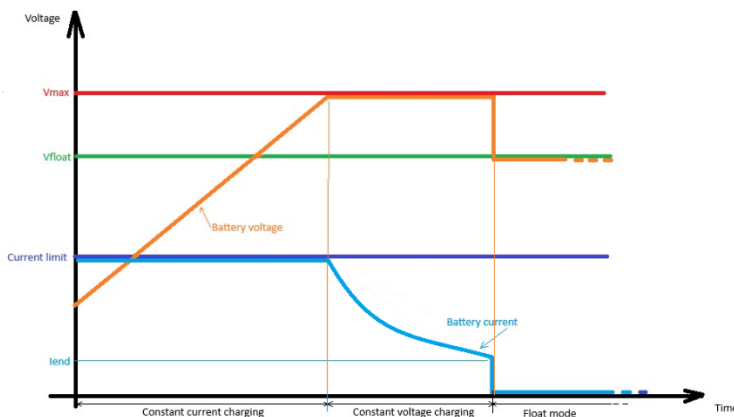

The temperature compensation can be defined as follows:

Define the maximum charging current.

Define Maximum battery charge voltage (V_{max}) $0^{\circ}C$.

Define float voltage (V_{float}) $0^{\circ}C$.

Define V_{max} thermal coefficient [$V/^{\circ}C$] V_{mt} .

Define V_{float} thermal coefficient [$V/^{\circ}C$] V_{ft} .

The actual values of V_{max} and V_{float} are calculated in firmware using the following equation:

$$V = T_{sns} * V_{ft} + V_{float@0^{\circ}C}$$

$$V = T_{sns} * V_{mt} + V_{max@0^{\circ}C}$$

Example for temperature compensation:

The graph shows the voltage vs temperature for:

$$V_{max @0^{\circ}C} = 30V$$

$$V_{float@0^{\circ}C} = 28.68V$$

$$V_{mt} = -0.09V$$

$$V_{ft} = -0.1V$$

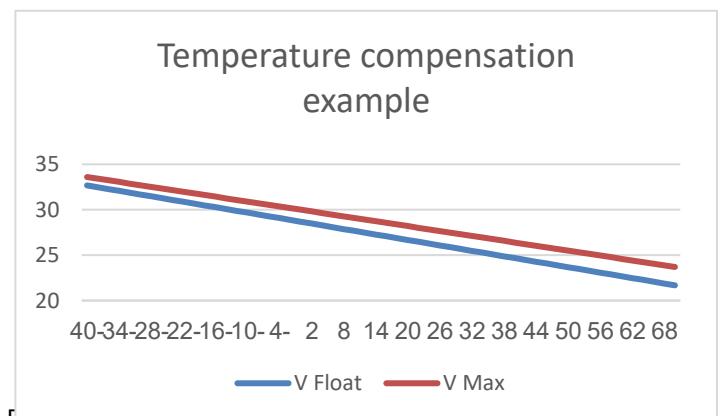

Date: January 31, 2026

OPTIONAL ADD-ONS:

CONTROL UNIT - OPTIONAL PLEASE CONSULT FACTORY:

M1041-XXX

Feature power switch, LED indicators, current / voltage monitor and more

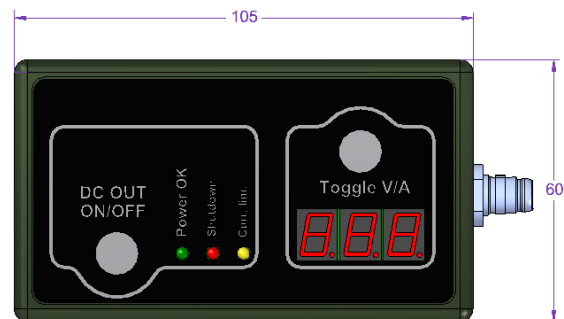
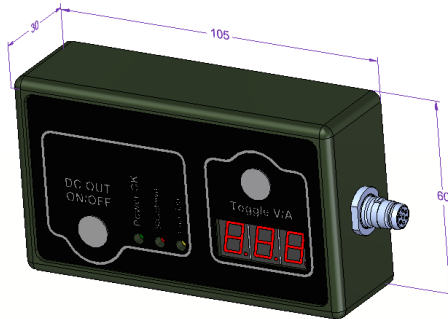

BATTERY CURRENT SENSE FIXTURE:

If an advance battery charging is required, a battery current sense is required.
 Many standard options are available, please consult factory for recommendation.
 If a custom solution is required, please consult factory.

OUTLINE DRAWING:

For detailed dimensions and tolerances see Drawing: M6620001

VIEW WITOUT DUST CUP

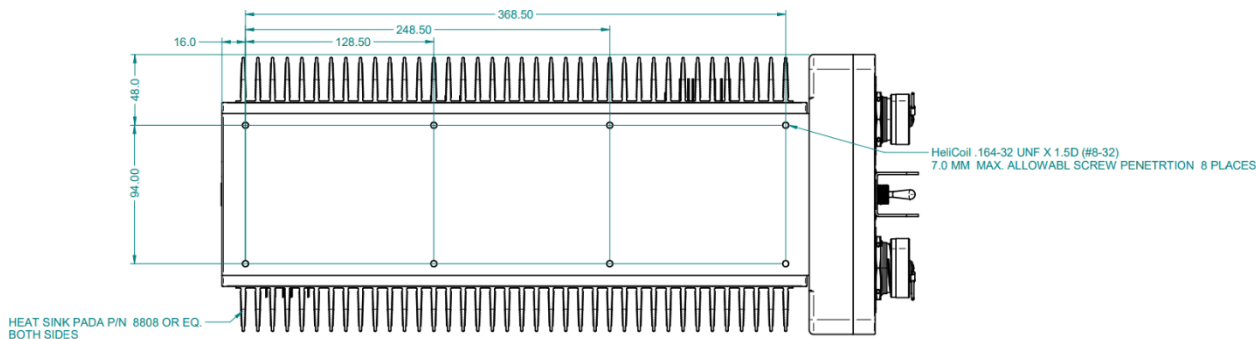
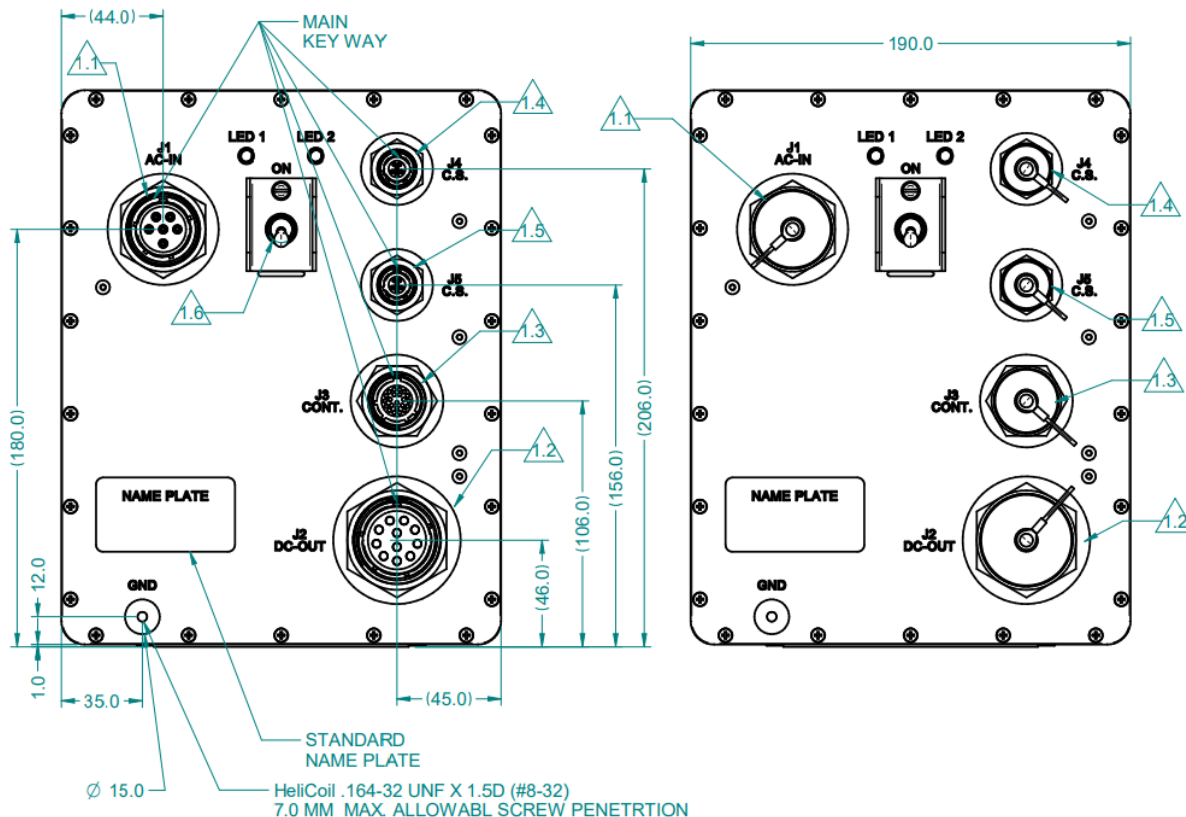

M6620-101 - AC/DC Power Supply

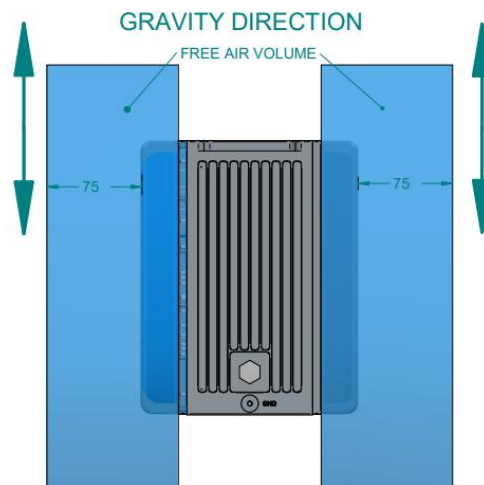
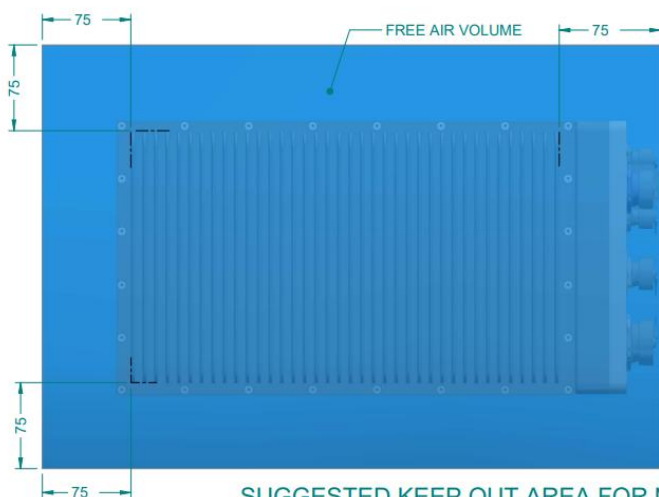
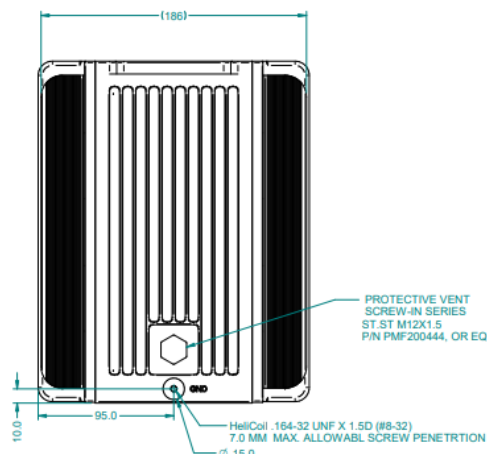
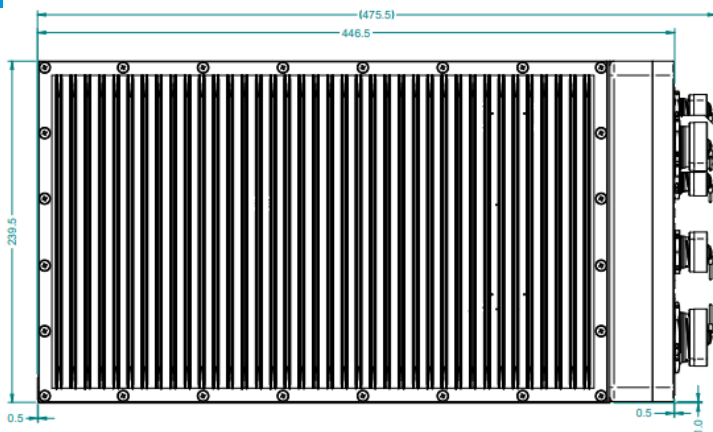

SUGGESTED KEEP OUT AREA FOR NATURAL CONVECTION

NOTES :

1. CONNECTORS LIST:
 - 1.1. AC POWER INPUT, J1, 8D7C17W06PN [SOURIAU] OR EQ., WITH CAP D38999/33W17R OR EQ.
 - 1.2. DC POWER OUTPUT, J2, 8D7C21W11SN [SOURIAU] OR EQ., WITH CAP D38999/33W21R OR EQ.
 - 1.3. CONTROL, J3, 8D7L13W35SN [SOURIAU] OR EQ., WITH CAP D38999/33W13R OR EQ.
 - 1.4. CURRENT SHARAING, J4, 8D7L09W35SN [SOURIAU] OR EQ., WITH CAP D38999/33W9R OR EQ.
 - 1.5. CURRENT SHARAING, J5, 8D7L09W35SN [SOURIAU] OR EQ., WITH CAP D38999/33W9R OR EQ.
 - 1.6. ON / OFF CIRCET BRACKER IULN1-1-62 OR EQ.
2. MTL AL 6061-T651
3. FINISH: CHROMATE CONVERSION COATING PER MIL -DTL-5541, LAST REVISION,TYPE I , CLASS 1A.
4. PAINT :
 - 4.1 PRIMER PAINTING :
APPLY SINGLE LAYER OF EPOGAL COATING, EPOXY PRIMER , TAMBOUR CODE No. 649-050[18].
THICKNESS OF DRY COAT LAYER : 50-70 µm.
 - 4.2 INTERMEDIATE COAT PAINTING :
APPLY TWO LAYERS OF COATING OF EPOXY POLYAMIDE ACCORDING TO MIL-PRF-22750[14].
THICKNESS OF EACH DRY COAT 25-40 µm TOTAL THICKNESS 50- 80 µm.
 - 4.3 TOP COAT PAINTING :
APPLY TWO LAYERS OF POLYURETHANE TOP COAT ACCORDING TO MIL-C-83286[12] OR MIL-PRF-85285[15], TOP COAT COLOR ID - RAL 6007
THICKNESS OF EACH DRY COAT LAYER : 25-40 µm ; TOTAL THICKNESS : 50- 80 µm.
 - 4.4 TOTAL PAINT THICKNESS
TOTAL THICKNESS OF DRY COAT OF PAINT 150-230 µm.
5. COOLING:
 - 5.1 FREE CONVECTION METHOD
6. WORKMANSHIP SHALL BE MIL-STD-454, REQ.T. 9
7. ENGRAVING
 - 7.1. CHARACTER HEIGHT : 4.0 [MM].
 - 7.2. CHARACTER DEPTH : 0.5 [MM].
 - 7.3. CHARACTER ARE CENTRALLY LOCATED.
 - 7.4. FILL ENGRAVING WITH BLACK LUSTERLESS EPOXY PAINT COLOR PER FED-STD 595 NO : 37038.

Note: Specifications are subject to change without prior notice by the manufacturer
Internal reference: R107_01292026

